

MERIT BADGE SERIES

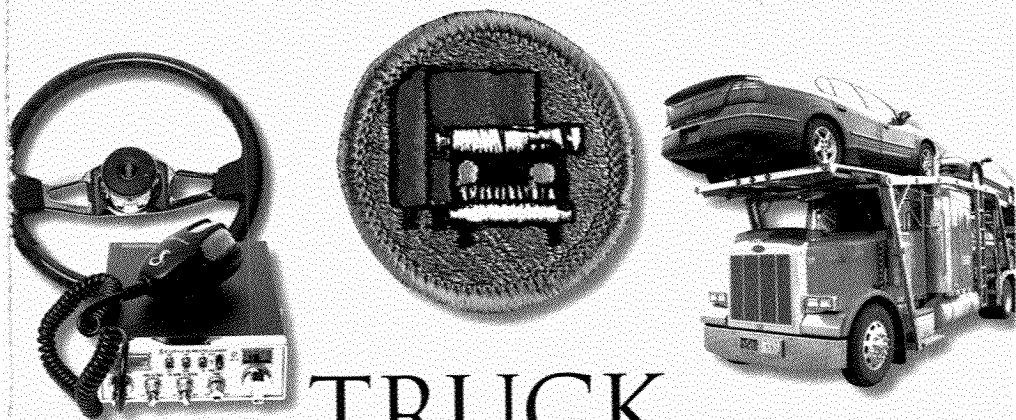

TRUCK TRANSPORTATION

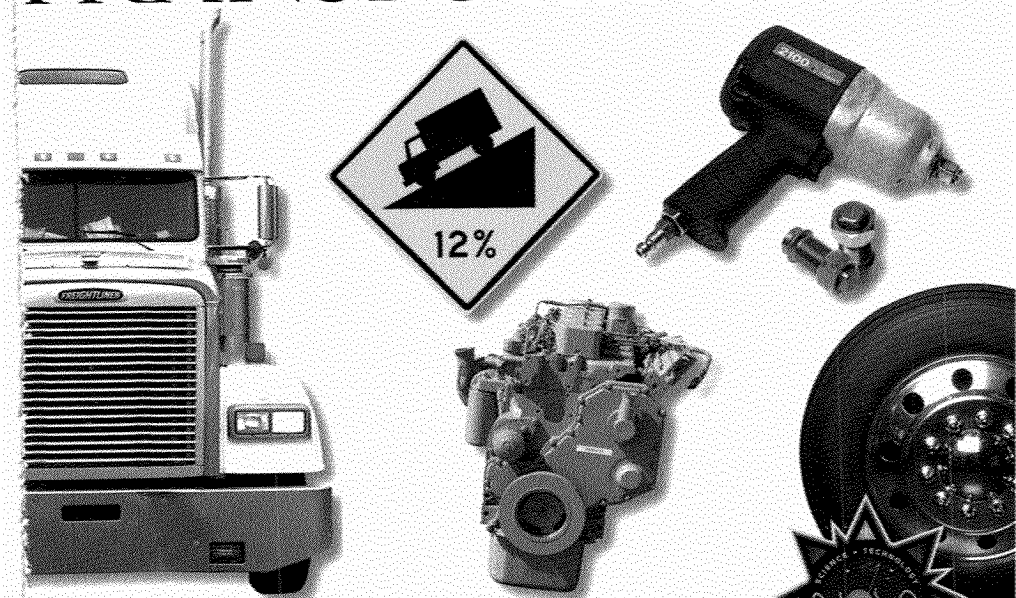

BOY SCOUTS OF AMERICA®

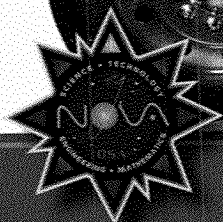

STEM-Based

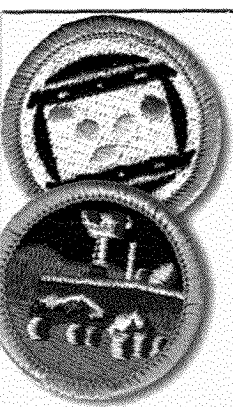

How to Use This Pamphlet

The secret to successfully earning a merit badge is for you to use both the pamphlet and the suggestions of your counselor.

Your counselor can be as important to you as a coach is to an athlete. Use all of the resources your counselor can make available to you. This may be the best chance you will have to learn about this particular subject. Make it count.

If you or your counselor feels that any information in this pamphlet is incorrect, please let us know. Please state your source of information.

Merit badge pamphlets are reprinted annually and requirements updated regularly. Your suggestions for improvement are welcome.

Who Pays for This Pamphlet?

This merit badge pamphlet is one in a series of more than 100 covering all kinds of hobby and career subjects. It is made available for you to buy as a service of the national and local councils, Boy Scouts of America. The costs of the development, writing, and editing of the merit badge pamphlets are paid for by the Boy Scouts of America in order to bring you the best book at a reasonable price.

Send comments along with a brief statement about yourself to
Pilots and Program Development, S272
Boy Scouts of America • 1325 West Walnut Hill Lane • Irving, TX 75038
If you prefer, you may send your comments to merit.badge@Scouting.org.

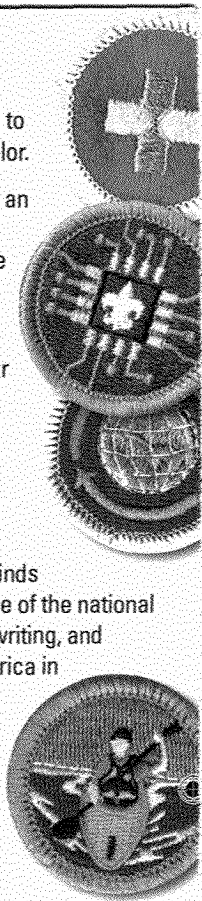

BOY SCOUTS OF AMERICA
MERIT BADGE SERIES

TRUCK TRANSPORTATION

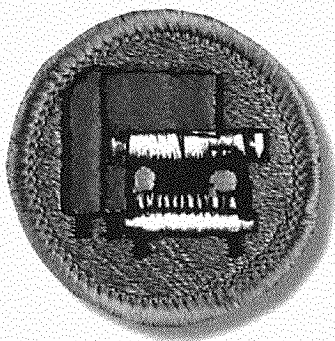

"Enhancing our youths' competitive edge through merit badges"



BOY SCOUTS OF AMERICA®

Requirements

1. List the major truck lines serving your town.
2. Do the following:
 - a. Describe the role of truck transportation within commerce (the movement of goods, funds, and information).
 - b. Describe how trucks fit into a company's supply chain. This could be a manufacturer, importer, wholesaler, or retailer.
 - c. On paper, map out how goods that are manufactured overseas are transported to a retailer in this country.
3. Describe the difference between the gasoline engine and the diesel engine that power trucks. List the advantages of each.
4. Visit a truck terminal and complete items 4a through 4e. After your visit, share what you have learned with your counselor.
 - a. Find out what kind of maintenance program the company follows to help keep its fleet, drivers, and the roadway safe.
 - b. Find out how dispatchers maintain communication with drivers on the road.
 - c. Talk with a professional truck driver about safety. Learn about the truck driver's rules of the road for safe driving. List five safe-driving rules every professional truck driver must follow.

- d. Review the driver's log and find out what kind of information the log contains.
 - e. Learn about important federal regulations that help ensure public safety.
5. Do the following:
- a. Outline the general organization of a trucking company. Describe what each department does.
 - b. List five positions with trucking companies and describe each one.
6. Name five government agencies that work closely with the trucking industry. Describe their role.
7. List five different kinds of trucks. Tell the service each provides.
8. Assume that you are going to ship by truck 500 pounds of goods (freight class 65) from your town to another town 500 miles away. Your shipment must arrive within three days. Explain in writing:
- a. How to prepare the shipment
 - b. How to compare at least three carriers for time in transit and rates
 - c. How to choose which carrier to use
 - d. How to insure the shipment for damages
9. Define the following terms: bill of lading, ETA, logbook, intermodal, containers, tariff, shippers, carrier, consignee, drayage, cartage.
10. Learn about opportunities in the field of truck transportation. Choose one career in which you are interested and discuss with your counselor the major responsibilities of that position and the qualifications, education, and training such a position requires.

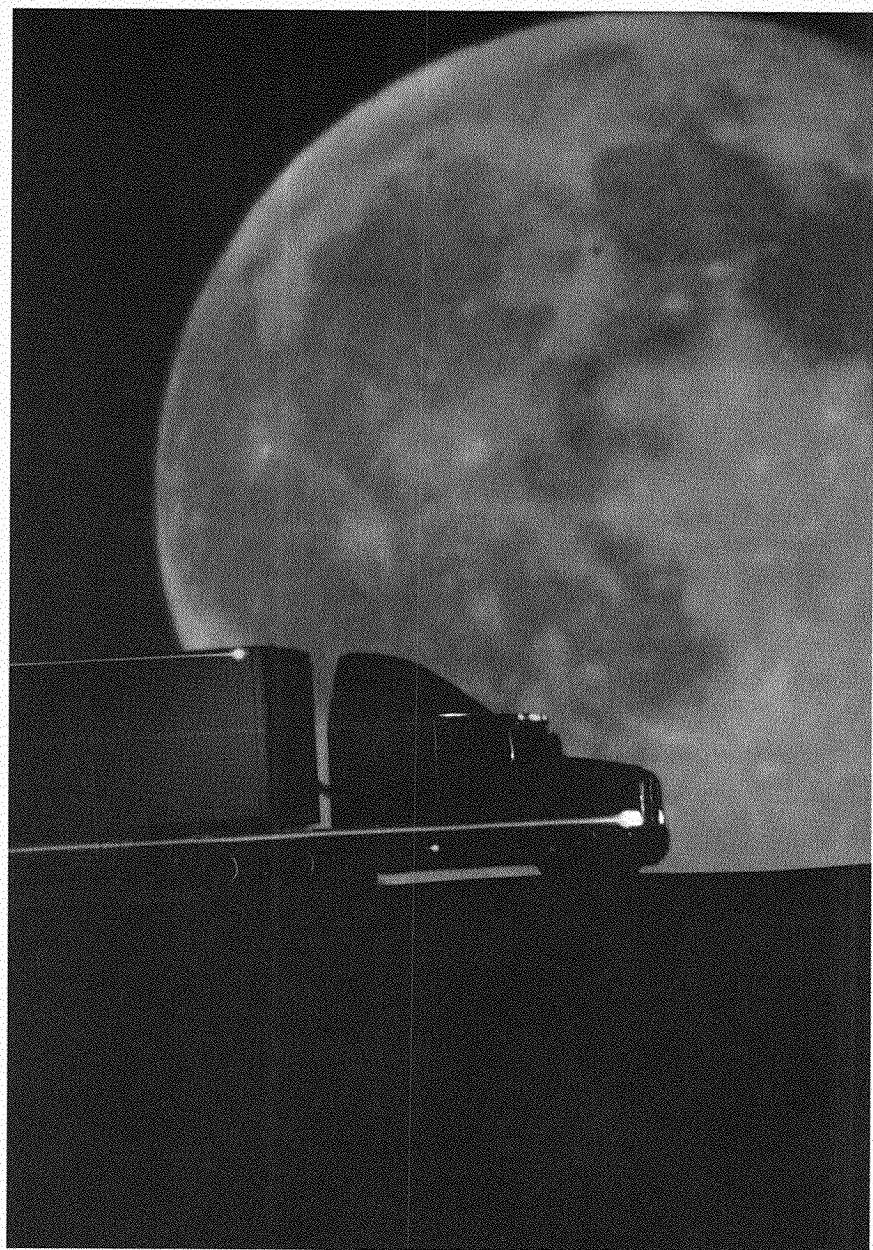

Contents

Trucks and Society	7
Trucking Regulations and Safety	16
How Trucking Companies Operate	23
Keep That Truck Running	27
Getting From Here to There	33
Careers in Truck Transportation	39
Trucking Terms	44
Truck Transportation Resources	47



Trucks and Society

Trucking is a large and important industry. No matter where you live, a day is unlikely to go by when you will not see a truck. We use these vehicles to deliver almost every material item we buy. Without trucks, our economy would not work efficiently.

Just think for a minute of all the things that are moved by trucks. The clothes you wear, the food you eat, the books you read, your camping equipment, your video games—all of these things at some point are moved on a truck.

Trucks are the main means of moving freight in the United States. Even products moved part of the way by another means of transportation, such as rail or ship, are at some point carried by truck. Not surprisingly, more than 80 percent of American towns rely solely on trucks to bring in the goods that are sold there.

Trucks are everywhere. There are about 15.5 million trucks on the roads of the United States, not counting those used for government and farm work. It is hard to imagine what our lives would be like without trucks.



According to the American Trucking Associations, the trucking industry employs more than 9 million people. That is more workers than any other private industry in the United States. About 3.5 million of these employees are truck drivers.

There are a couple of ways you can find out which major truck lines serve your town. Look in the yellow pages of your local telephone directory or, if you have a computer, search on the Internet (with your parent's permission).

Trucks often are favored as a means of transporting goods because they are both quick and inexpensive. Shipping by airplane is the fastest way to move goods, but it's a very expensive way to transport cargo. Railroads are economical but slower than trucks and generally only move items in large quantities or in bulk, such as grain, lumber, coal, and automobiles. Ships are cost-efficient, too, but they can move goods only between ports. So, the versatile truck offers the best combination of cost-effectiveness and speed for moving goods within the United States.

transportation mode. Method of transportation such as truck, air, rail, ship, or pipeline.

Trucks often work in combination with other *transportation modes*. For example, trucks haul large freight *containers* (weather-tight steel boxes used in shipping) to oceangoing container ships that move goods in containers all over the world. Or, truck trailers may be loaded onto rail flatcars for transport over long distances. When the train reaches a rail yard near the destination, the trailer is hooked to a truck tractor again and the goods are delivered to the customer. This is an example of *intermodal*, or *piggyback*, transportation.

So, as you can see, trucks are important to the way we live.

History of the Truck

The world's first motorized truck was built in Germany in 1896 by a company owned by Gottlieb Daimler (1834–1900), a pioneer in the development of the gasoline engine and the automotive industry. This was 10 years after the same company built its first automobile. By World War I (1914–18), trucks were in wide use, and by 1923, the fuel-saving diesel engine was developed. By 1935, more than 329,000 trucks were registered in the United States.

During World War II (1939–45), trucks were the main method of moving troops and supplies, largely replacing horse-drawn wagons. After World War II, the U.S. government decided that an efficient national highway system was important to the security of the country. The Federal-Aid Highway Act provided money to build 42,000 miles of modern highways across the United States. These new highways, the beginning of the interstate highway system, made truck transportation even more efficient and popular.

Motor carriers dominate the transportation industry, representing the overwhelming majority of the domestic transportation market in both volume and revenue.



The introduction of the motorized truck made deliveries quicker and more efficient in the early 1900s.

Major Dates in Automobile and Truck History

1896	First motorized truck made
1899	First automobile hauler built
1903	First windshields were used
1904	Steering wheel replaced hand levers for steering
1912	Electric lights replaced lanterns
1922	Backup lights were first used
1926	Shockproof glass used in windshields
1927	Chrome trim first used
1931	Sun visors first used
1938	Turn signals used in all new trucks
1960s	Air-conditioning becomes a standard feature in trucks
2000s	Improvements in fuel efficiency become focus

Types of Trucks

There are different trucks for different purposes, and you probably have seen many different kinds at work. On the highway, there are tractor-trailers for general cargo, trucks that haul dirt, trucks that deliver new cars to a showroom, and trucks that carry bulk liquids. In your neighborhood, you may have seen special trucks that pick up trash or recycling materials. Refrigerated trucks deliver frozen produce to retailers. Flatbed trucks are used to move cargo that is not easily stowed, loaded into, or unloaded from the more common tractor-trailer.

Before meeting with your counselor, think of the different types of trucks you have seen and what they transport. The next couple of pages show several of the more common trucks on the road.



The tractor-trailer is the typical “big rig” used to transport most of the nation’s freight. These are a common sight on streets and highways.



Tanker trucks are used to haul large amounts of liquid products, from milk and corn syrup to chemicals, gasoline, and heating oil.



The flatbed truck typically is used to haul very large items that will not fit in a closed truck or that cannot easily be unloaded from the back of a truck trailer.

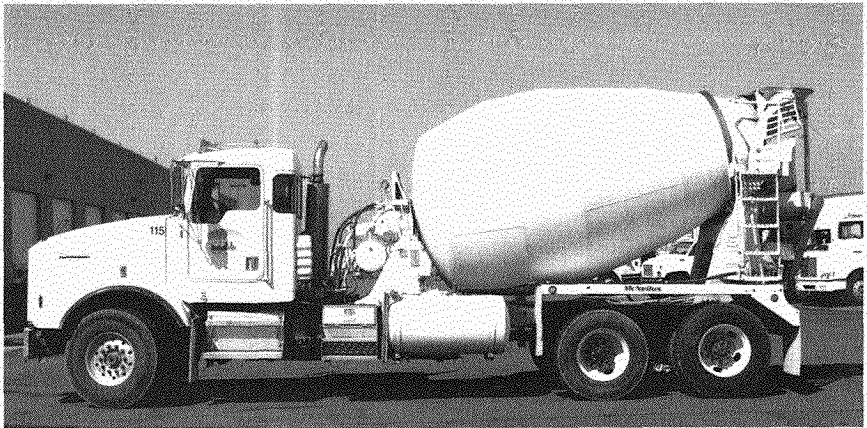

Cement mixers mix cement powder with water in a rotating barrel and haul the cement mixture to a construction site.

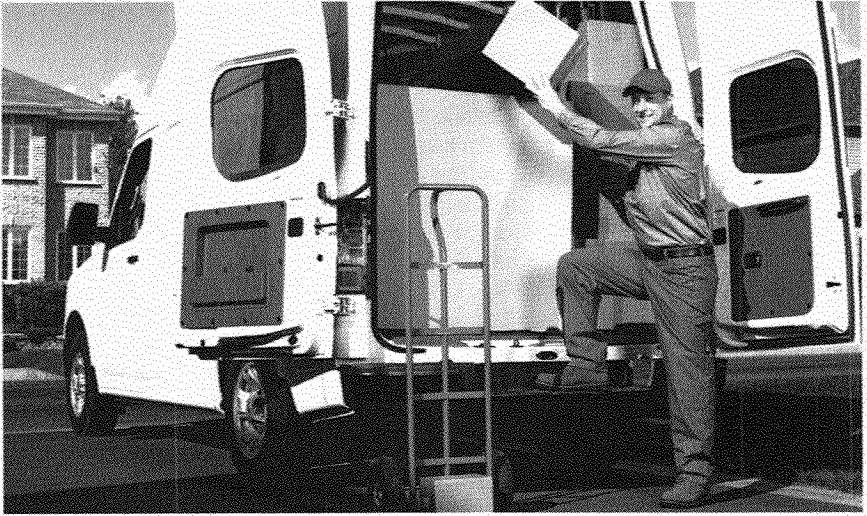

Delivery vans are used by companies to deliver smaller items to businesses and homes. They are easier to drive and more economical to operate than the bigger trucks.



Garbage trucks pick up and remove trash from neighborhood homes and businesses. The trash is dumped into the garbage truck, then the full truck is taken to a garbage collection point or recycling center for emptying.

Trucks and Commerce

Trucks play a major role in today's world economy. They provide a smooth flow of goods through the global *supply chain*. Just think for a minute about how trucks fit into U.S. *commerce*. Trucks pick up *raw materials* at one company and deliver them to another, where they are used to make a product. That product may then be shipped by truck to a *warehouse*, where it is stored. The product may be shipped again by truck to a retailer, where it is sold to a consumer.

supply chain. The various companies involved in making something from raw materials into a finished product that is then available to the consumer.

commerce. The movement of goods, funds, and information.

raw materials. Resources that are converted into another product.

warehouse. A place where goods are stored.

importation. The process of buying something from another country.

Trucks also play a large role in the *importation* of goods from foreign countries. At each stage of the journey that typically is taken to import something into the United States from another country, trucks play a part.

Say a company in the United States sells hiking boots to camping equipment stores. These boots were made in Brazil and transported by ship to a port on the East Coast of the United States. The leather used to make the boots was shipped by truck from the tanneries to the shoe factory. At the factory, the leather was manufactured, along with other raw materials, into hiking boots.

These finished boots were packed into cardboard boxes and loaded into cargo containers that were transported by truck to the seaport. The cargo containers were loaded onto enormous container ships that brought the cargo to a U.S. seaport.

Upon the ship's arrival in port, the container was off-loaded and again moved by truck to the shoe company's warehouse. This movement of transporting goods to and from a seaport is also known as *cartage*. Once a camping goods retailer orders some boots, they are shipped by truck to the store.

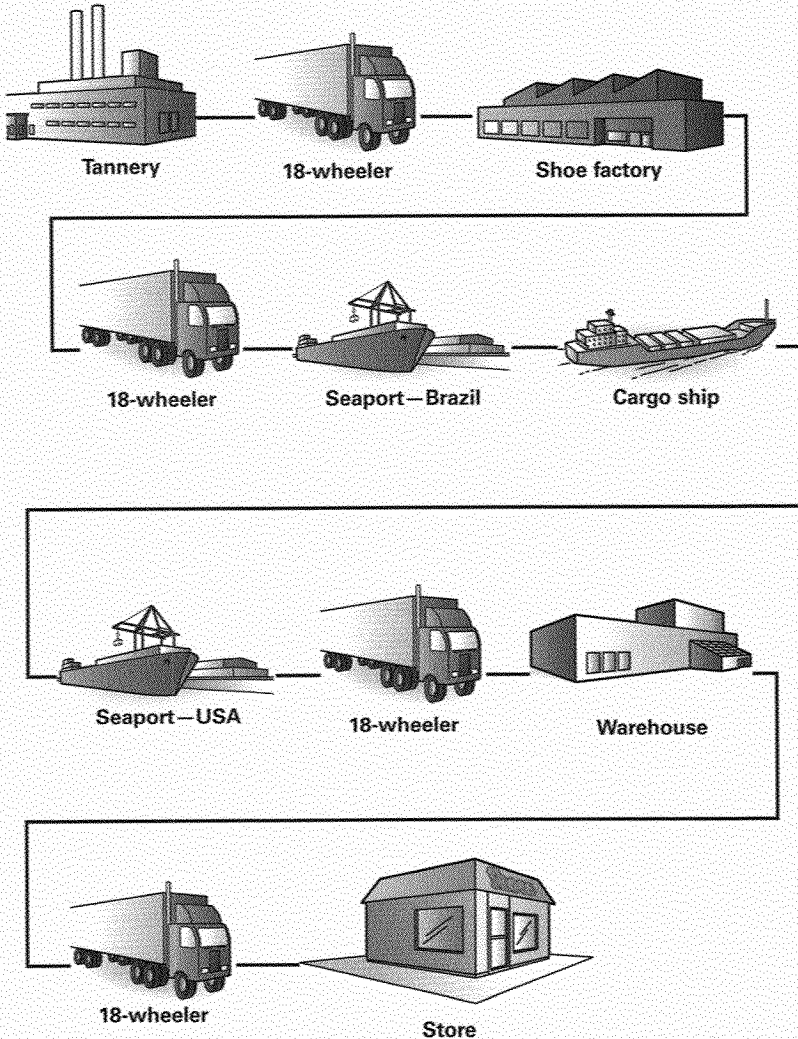

Trucking Regulations and Safety

Trucking regulations and safety go hand in hand.

The Influence of Government

As the trucking industry grew, it became so important to the economy of the United States that the federal government stepped in to set some rules. Through the Motor Carrier Act of 1935, the government regulated where a trucking company, or *carrier*, could operate and what it could charge for its services. An agency known as the Interstate Commerce Commission enforced these rules, which were very helpful at the time they were introduced.

By the 1970s, these regulations were out-of-date and an obstacle to competition in the trucking industry. The government recognized the situation and, starting with the Motor Carrier Act of 1980, the trucking industry became largely deregulated (made less restrictive). Further controls were lifted through the 1990s, and by 1995 the ICC was eliminated.

Today, the trucking industry is monitored by several government agencies that are primarily concerned with truck registration, driver licensing requirements, and safety issues. Here are some of the most important agencies.

USDOT 104249

Commercial vehicles are monitored by the U.S. Department of Transportation, which issues a number such as the one shown here.

The **Department of Transportation** is responsible for making national transportation policy and promoting inter-modal transportation. Specific agencies that directly affect trucking fall under the DOT's control.

The **Federal Highway Administration** is responsible for the improvement and safety of the nation's highways.

The primary mission of the **Federal Motor Carrier Safety Administration** is to help prevent commercial motor vehicle-related deaths and injuries by enforcing safety regulations, improving trucking equipment, and increasing safety awareness.

The **National Highway Traffic Safety Administration** is responsible for finding ways to reduce deaths, injuries, and economic losses resulting from motor vehicle crashes. The NHTSA sets and enforces safety performance standards for motor vehicles and equipment such as truck trailers.

The **Research and Special Programs Administration** governs the safe transportation and packaging of hazardous materials by all modes of transportation.

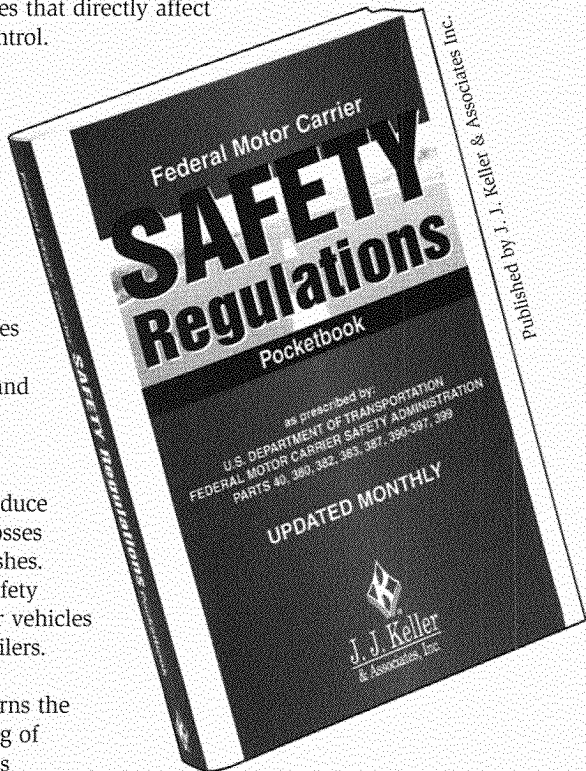

The **Surface Transportation Board** is responsible for the economic regulation of interstate (transportation between states) surface transportation within the United States. Its mission is to ensure that competitive, efficient, and safe transportation services are provided to meet the needs of *shippers* (companies that hand over freight to a trucker for transportation), receivers (*consignees*), and consumers.

In addition to these federal agencies, a number of other regulatory agencies affect the trucking industry.

- **Some state public utilities commissions** are charged with ensuring safe, reliable, and competitively priced transportation services.
- **State motor vehicle departments** control licensing, registration, and safety regulations of all motor vehicles in operation in their state.
- **State and local police departments** enforce the law.

Together, all these separate agencies help ensure public safety on our roadways.

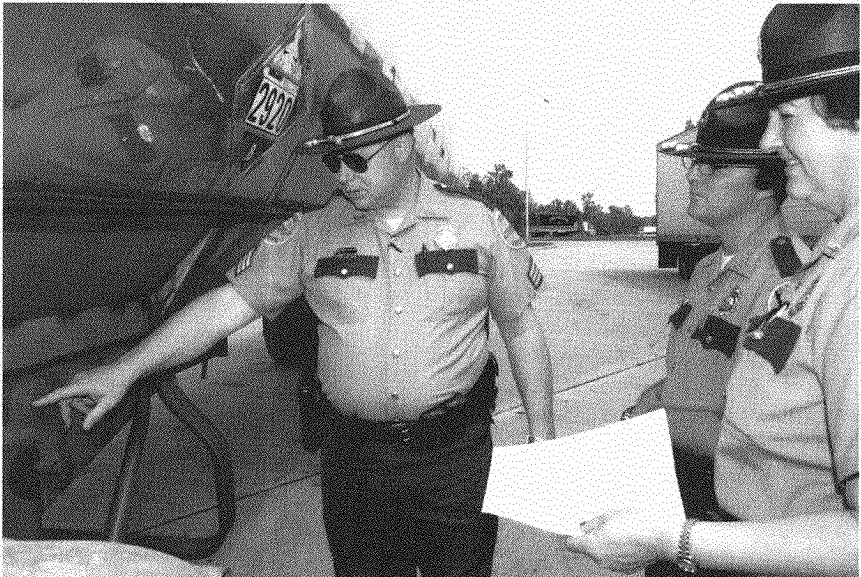

State troopers help keep our highways safe, too, by enforcing the law.

Safety and Trucking

A truck driver's first priority is safety. A driver must always be concerned with driving in a safe manner. A careless or reckless driver could damage the truck, the cargo, or other people's property. Worse yet, such a driver could get injured or cause injury to others. That is why trucking companies make efforts to train their drivers well and strongly enforce safety.

The Federal Motor Carrier Safety Administration reports that the average cost of all large-truck crashes is about \$91,000 per crash. Because of concern for people's lives and the cost of accidents, trucking companies work hard to make sure their equipment is safe and their drivers operate their vehicles safely.

Here are some important safe-driver practices.

- Watch for dangers by scanning ahead, to the sides, and to the rear of the truck.
- Make sure other drivers understand your intention, whether it is to change lanes, slow down, or stop.
- Understand the condition of the road and drive as slowly as is necessary.
- Buckle up; always wear your safety belt.
- Never exceed the speed limit.
- Keep a safe distance behind the vehicle in front of you.
- For better visibility by other motorists, use running lights when driving in daylight.

Safe drivers rarely have accidents. They are alert and well-prepared, and they try to anticipate dangerous situations in time to prevent accidents.

Don't Hang Out in the No-Zone. No-zones are danger areas around vehicles where crashes are more likely to occur. Such areas include actual blind spots where your car "disappears" from the driver's view (or where another vehicle on the road "disappears" from your own view). A safe driver is a predictable driver who stays out of the no-zone.

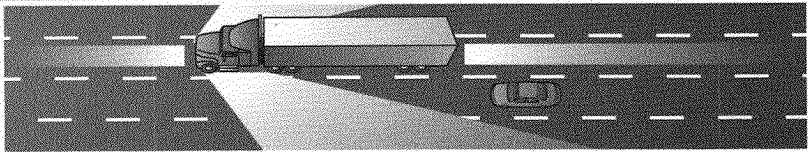

The Department of Transportation estimates that more than 500,000 truck accidents occur every year.

A tired driver is much more likely to have an accident than a well-rested one. Because the U.S. government is very concerned about the safety of our roadways, federal laws limit the length of time a truck driver may operate a vehicle. These regulations are known as the hours-of-service rules.

- A driver may not operate a truck for more than 11 hours in a day.
- A driver can take on additional responsibilities like loading and unloading but may not work more than 14 hours straight in a day.
- A driver must be off for 10 hours straight every day.
- Drivers cannot drive more than 60 hours in a seven-day period.

To ensure these rules are followed, every driver involved in interstate transportation must complete a driver's log for every day worked. This log shows the driver's name, the date, and the number of miles driven that day. Drivers keep a *logbook* of all their daily logs.

Most people's biological clocks make them especially likely to feel sleepy at three specific times during the day. One is the afternoon lull, from 2 p.m. to 5 p.m. The others are early in the morning and late at night, which is by far the most dangerous time for drivers.

When you drive, pay careful attention to the behavior of other drivers near your vehicle. If you see them weaving, drifting into another lane inexplicably, heading for a ditch, or exhibiting any other unusual behavior, actively avoid them—slow down and stay behind them. If you yourself start feeling drowsy while driving, get off the road immediately. Get out and take a brisk walk to wake yourself up, or have someone who is well-rested take the wheel.



In the end, it takes effort from trucking companies, individual drivers, and government agencies to help make sure highways are as safe as they can be.

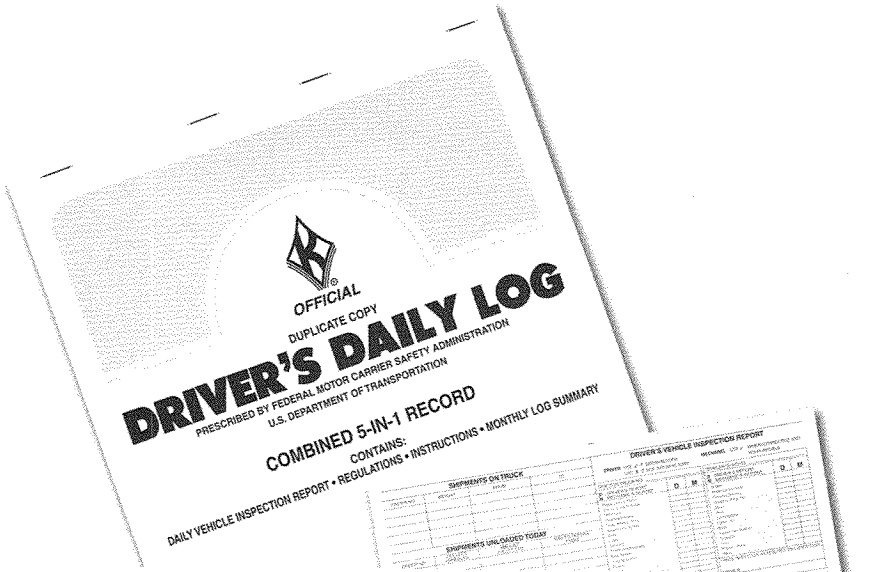

Drivers Daily Log

(One Calendar day = 24 hours)

March 30, 2013 500 Tractor 1234 / Trailer 9876

(Month - Day - Year) (Total miles driven today) Vehicle numbers - (Show Each Unit)

Rapid Trucking (Name of the Carrier) *Robert Johnson*

500 Park Avenue Phoenix, AZ (Main office address) None (Name of the Co-driver)

I certify that these entries are true and correct:
Robert Johnson
(Driver's Signature)

	Mid Night												Total Hours												
	1	2	3	4	5	6	7	8	9	10	11	12													
1 Off Duty																								10.00	
2 Sleeper Berth																								5.00	
3 Driving																								9.00	
4 On Duty																								0.00	
Mid Night	1	2	3	4	5	6	7	8	9	10	11	12	1	2	3	4	5	6	7	8	9	10	11	12	
Remarks																								24.00	

PRO or Shipping Number 123-456789-0

The driver's daily log shows what the driver did that day while on duty.



How Trucking Companies Operate

Trucking companies come in many different shapes and sizes. The majority—approximately 97 percent—of all trucking companies operate 20 or fewer trucks. Some trucking companies are made up of just a driver and that driver's truck. Such business people are known as *owner-operators*—drivers who own and operate their own truck and trucking company.

Except for the very smallest operations, most trucking companies are organized along similar lines and have similar departments to handle the various aspects of the business. Generally, trucking companies operate out of a *terminal*, a building where a number of activities take place. These include:

- Loading freight on and off the trucks
- Sorting freight for delivery
- Sending trucks out to pick up freight
- Repairing and maintaining the trucks
- Conducting office work related to the trucking company's operations
- Storing trucks when they are not out on the road

The following chart shows how the various departments and responsibilities within a trucking terminal might be organized. Of course, each company is different. When you visit a truck terminal, ask the terminal manager how that terminal is organized.

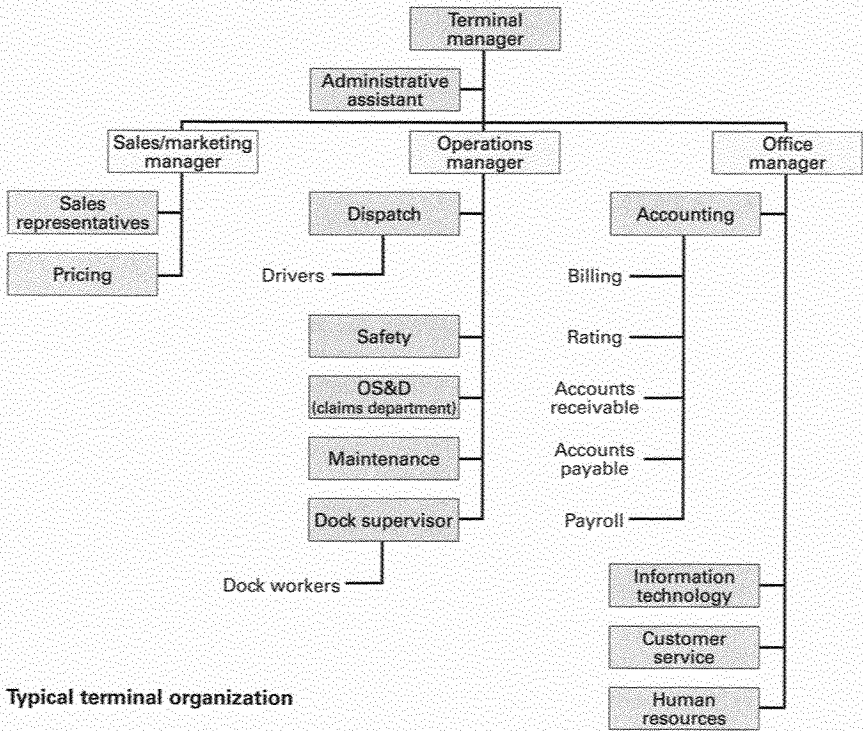

Typical terminal organization

Trucking Company Departments

Here are some of the departments likely to be found within a trucking company.

Sales and Marketing. This group of people represents the company to the public and helps keep customers happy. Sales people call on shippers to sell the trucking company's services. They must have a good understanding of the company's services and the needs of their customers. The marketing team is responsible for developing new services, pricing the company's services, and advertising.

Operations. These people “move” the freight. Within the operations group you will find the dispatcher, drivers, dock workers, and the safety group, maintenance team, and cargo claims people who handle *OS&D* (over, short, and damaged) goods.

Administration. These office workers handle the paperwork associated with making a trucking company work.

- **Accounting.** This group maintains the company’s financial records, bills customers, pays bills, and handles payroll.
- **Information Technology.** The IT people develop and maintain the company’s computer systems.
- **Customer Service.** These company representatives help customers. They may track down a lost shipment, schedule a pickup, answer a question on the proper way to ship something, or explain how long it will take or how much it will cost to ship.
- **Human Resources.** The HR people locate, hire, and train employees for the company. They also may settle disputes between management and the workers.

One requirement for the Truck Transportation merit badge calls for a visit to a trucking terminal. As you probably can tell by now, a lot of activity happens there. Because trucking terminals are busy places, it is important to schedule a visit for a time that is convenient to the company, probably at least two weeks in advance.

When calling, ask to speak to the terminal manager. Explain who you are and what you want to do. Most terminal managers will be happy to meet with you. If you have difficulty making an appointment, speak to your merit badge counselor for assistance. Your counselor may have other suggestions, or may have a contact at a local trucking company.





Keep That Truck Running

One of the keys to truck safety is proper maintenance. The driver plays a major role in this by inspecting the truck at the beginning and end of each run. These daily inspections are required by government regulations and go a long way toward making sure the truck is safe when it hits the road. The following are among the things the driver checks to make sure the truck is working properly: fuel, oil, and coolant levels; gauges, brakes, horn, lights, tires, hoses, exhaust system, suspension, fuel tank.

In addition to the driver's daily checks, trucking companies have fixed schedules for maintaining their trucks. Some of the maintenance work performed by mechanics includes

- Changing the engine oil and oil filters
- Checking and adjusting tire pressure
- Tuning the engine
- Changing the brakes
- Rebuilding the transmission
- Servicing the cooling and heating systems

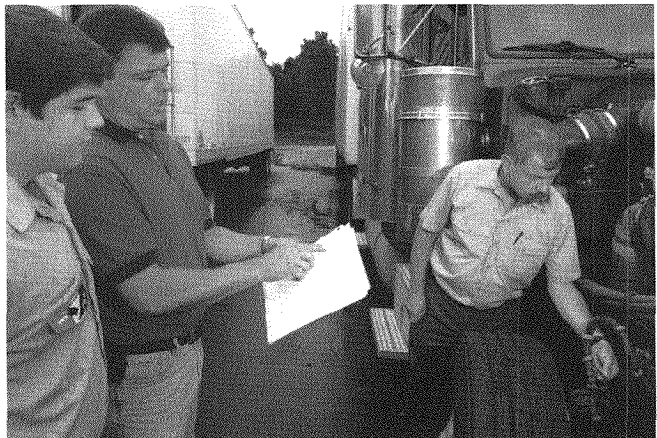

Keeping trucks well-maintained helps ensure not only the driver's safety and safety on the road, but also helps keep trucks working so that carriers can stay in business.



When you visit a trucking terminal, ask the terminal manager or the maintenance manager

- How the company maintains its vehicles
- How daily checks are made by truck drivers
- How often the maintenance department performs service on the trucks
- If you can see a schedule of preventive maintenance for the vehicles



Keeping a truck clean helps prolong the life of the truck and ensure the company maintains a “clean” image.

The Heart of the Truck: The Engine

There are two main types of truck engine—gasoline and diesel. The gasoline engine in a truck is similar to that used in most automobiles and is typically found in smaller trucks such as pickups, vans, and sport utility vehicles (SUVs). Most large trucks are powered by diesel engines. While diesel engines are used in some cars and small trucks, they are most commonly found in big trucks.

Diesel and gasoline engines have much in common.

- They are both *internal combustion engines*, which means the power they produce is a result of explosions occurring within cylinders inside the engine block.
- They both use a mixture of air and fuel as part of the process of creating an explosion.
- They both have pistons and valves.

There are some differences between the diesel and gasoline engine, primarily in the way the fuel and air mixture is ignited. Gasoline engines use a device called a spark plug to ignite the fuel-air mixture; diesel engines rely on heat made by air compression.

Diesel engine parts are exposed to higher temperatures and compression pressure than are gasoline engines. Therefore, diesel engine parts must be more durable.

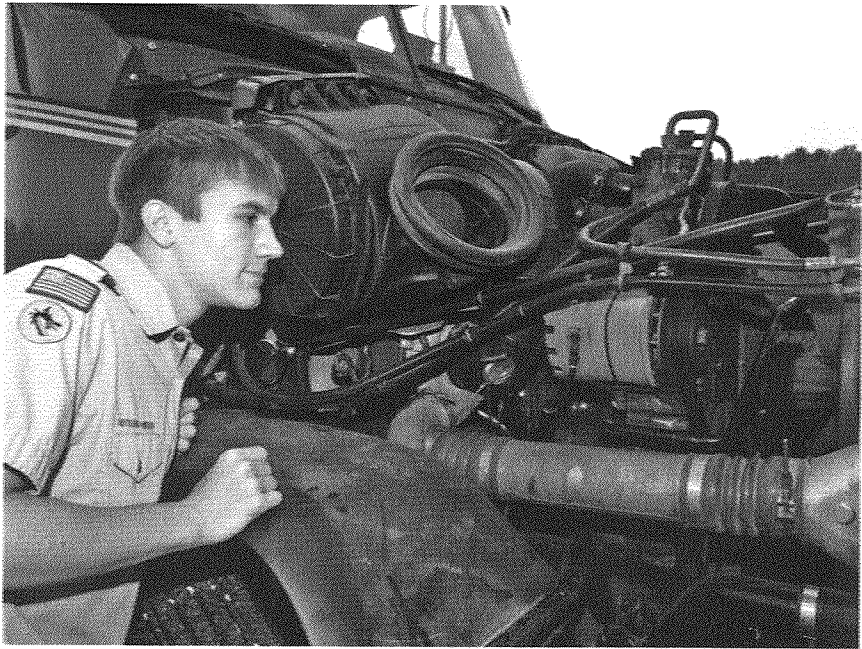

Diesel engines have some advantages over gasoline engines.

- They have more power than gasoline engines.
- They operate more efficiently.
- They last longer and are more reliable.
- They require less service.

Here are the advantages of gasoline engines over diesel engines.

- They cost less to produce than diesel engines.
- More local service locations are available, making servicing more convenient.

Diesel engines work like this.

- The starter turns the engine and sets the crankshaft in motion.
- The crankshaft begins a process that pushes the pistons down in the cylinders.
- Air is pulled in as the pistons travel down in the cylinders.
- When the pistons start to move up in the cylinders, the air is compressed and made very hot.
- When the pistons are near the top of the cylinders, diesel fuel is injected into the cylinders, where they meet with the super heated air. This creates an explosion called *combustion*. The temperature and pressure in the cylinder becomes higher as the diesel fuel burns.
- The combustion pushes the pistons down in the cylinders.
- As the pistons reach the bottom of the cylinders, exhaust valves open.
- The pistons move up in the cylinders and burned gases are pushed out.

This process continues with each explosion, passing power through the transmission and drive shaft to the wheels.



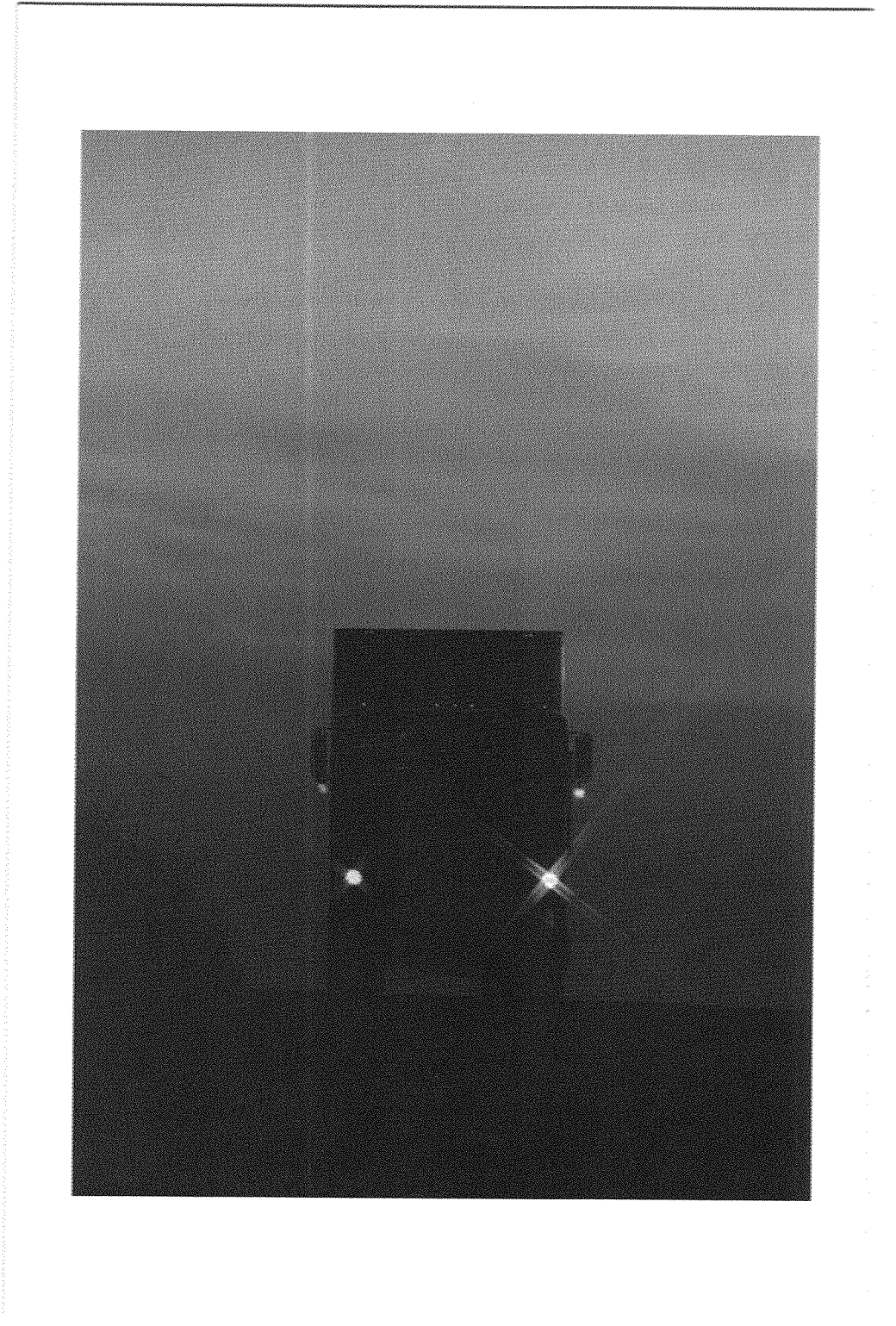

Getting From Here to There

Making a shipment via truck transportation involves a number of steps. There are many things a shipper should be aware of before making a shipment.

- **What is being shipped.** This affects the cost of shipping and how the cargo will be packaged for protection.
- **Where the cargo is going.** The destination will affect the cost of shipping. Generally, the farther you ship something, the more it will cost to ship.
- **The weight of the shipment.** The weight will affect the cost to ship and how it is packaged. In general, the more something weighs, the more it will cost to ship.
- **The estimated time of arrival (ETA).** Some carriers can deliver freight to certain locations faster than others. You need to know when the receiver needs the shipment to arrive, then pick a carrier that can meet that date.
- **How the goods should be packaged.** Items need to be packaged so they arrive intact. Some items may be fragile or require special packaging or handling. Everything does not get packaged the same way. A computer monitor needs to be packaged differently from a tent.
- **How much it will cost to ship your cargo.** Freight is not shipped free of charge; this is how trucking companies make a profit. It's important to find out the cost of shipping up front.

After you have found several reliable and reputable carriers that meet your requirements, choose the one with the lowest cost.

Not all trucking companies charge the same price nor offer the same services. Be sure to choose one that is reliable, reputable, and can deliver your shipment on time.

Now let's try to "ship" something by truck. Let's say you have 12 unassembled bicycles to ship from New Jersey to California. As the shipper, you are responsible for preparing the goods for shipment. You pack the unassembled bicycles carefully in strong cardboard boxes and then secure the boxes to a pallet—kind of like the one you see here—so it is easy to load and unload the cargo.



Next, weigh the pallet of bicycles so you know the total weight of your shipment. You will need to give this information to the trucking company. Now check your local yellow pages or search the Internet for three trucking companies near you. Call each one and ask for customer service. Give the customer service representative the details of your shipment, including the following.

Before you use the Internet, always get your parent's permission.

- Explain what you are shipping.
- Tell how much it weighs.
- Tell where it is going.
- Ask when it will be available for pickup.
- Say when it needs to be delivered.

After providing these details, ask if the trucking company can meet your needs, when someone will pick up the shipment, when the shipment will be delivered, and what it will cost to ship your cargo. Make your choice based on whether your shipment can be picked up and delivered on time. If all three trucking companies can perform the delivery when it is needed, choose the least expensive one.

When the carrier arrives to pick up your shipment, you must give the driver a *bill of lading*. This document tells the driver what is being picked up, where it is going, how much it weighs, and who is paying the freight charge—you (the shipper) or the *consignee*. The driver will sign this bill of lading and give you a copy as a receipt. It is important to keep this document in case the shipment is lost or damaged. The bill of lading serves as your proof that the goods have been shipped.

Truck freight prices are set by using the class rate system. This is a way of taking the thousands of different possible products and grouping them into similar classes to simplify freight pricing. There are 18 different freight classes, ranging from class 50 to class 500. The higher the class rating of a product, the more it will cost to ship.

In general, inexpensive items that are heavy, dense, and unlikely to be damaged during shipping have a lower class rating than items that are expensive, lightweight, bulky, and easily damaged. Freight charges are listed at a cost per 100 pounds. As the weight of a shipment increases, the cost per 100 pounds decreases.

These charges are found in *tariffs*, which are a schedule of rates. Almost every carrier has its own set of rates, so it is important to compare different carrier prices to get the best one.







No one wants a shipment to get lost or damaged while it is in transit, but that sometimes happens. All reputable carriers have insurance to protect the value of freight if it is lost or damaged. However, the level of protection offered varies from carrier to carrier.

The image shows a 'STRAIGHT BILL OF LADING ORIGINAL - NOT NEGOTIABLE' form. The form is tilted and contains various fields for shipping information. At the top right, it says 'Bill of Lading Form No. 7-40847'. Below that, there are fields for 'Shipper's Name', 'Consignee's Name', 'Origin', and 'Destination'. The main body of the form is a large table with columns for 'Description', 'Weight', 'Volume', and 'Class'. At the bottom, there is a section for 'TARIFF' information, including 'Class', 'Rate', and 'Description'. The form is a standard document used in trucking to document the shipment of goods.

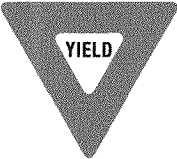
Bill of lading

Check with your carrier on the limitations of the coverage offered. If the value of your shipment exceeds the basic coverage offered, you should tell the carrier what the value is and advise the carrier that you want to buy extra insurance.

Extra insurance coverage is, in many cases, charged as a cost per \$100 of value. So if you want to buy insurance for something valued at \$1,000 and the cost for insurance is \$1 for every \$100 of value, insuring the shipment will cost \$10. Many large shippers have their own insurance policies, which protects the value of their goods beyond what the carrier provides.

Road Signs			
 <p>The driver must come to a complete stop.</p>	 <p>The driver must let the oncoming traffic go first.</p>	 <p>Do not enter.</p>	 <p>Indicates the driver is going in the wrong direction. Used many times along with the Do Not Enter sign.</p>
 <p>Indicates a pedestrian crosswalk.</p>	 <p>Indicates an area where children may be crossing the street. Often seen near schools and parks.</p>	 <p>Indicates an area where there is construction and workers may be present; be careful.</p>	 <p>Warns the driver of an area where there may be falling rocks; be careful.</p>

All drivers—not only truckers—must be familiar with and follow these common road signs.

07304 Jersey City, New Jersey, to 94404 Foster City, California

Class Rating	Less than 500 lbs	More than 500 lbs	1,000 lbs	More than 1,000 lbs	2,000 lbs	More than 2,000 lbs	5,000 lbs	More than 5,000 lbs	10,000 lbs	More than 10,000 lbs	20,000 lbs
500	684.61	554.60	472.28	397.12	345.33	283.06	248.51				
400	547.69	443.68	377.82	317.69	276.27	226.45	198.81				
300	410.77	332.76	283.37	238.27	207.20	169.84	149.10				
250	342.31	277.30	236.14	198.56	172.67	141.53	124.25				
200	273.85	221.84	188.91	158.85	138.13	113.22	99.40				
175	239.62	194.11	165.30	138.99	120.87	99.07	86.98				
150	205.38	166.38	141.68	119.14	103.60	84.92	74.55				
125	171.16	138.65	118.07	99.28	86.34	70.77	62.13				
110	150.61	122.01	103.90	87.37	75.97	62.27	54.67				
100	136.92	110.92	94.46	79.42	69.07	56.61	49.70				
92	128.02	103.71	88.32	74.26	64.58	52.93	46.47				
85	118.77	96.21	81.93	68.89	59.91	49.11	43.11				
77.5	108.98	88.28	75.18	63.21	54.97	45.06	39.56				
70	101.28	82.04	69.86	58.75	51.09	41.87	36.76				
65	95.26	77.17	65.71	55.25	48.05	39.38	34.58				
60	90.28	73.14	62.28	52.37	45.54	37.33	32.77				
55	85.31	69.11	58.85	49.48	43.03	35.27	30.97				
50	80.25	65.01	55.36	46.55	40.48	33.18	29.13				

This sample tariff shows the cost per 100 pounds for all weights and all classes covering shipments from Jersey City, New Jersey, to Foster City, California.

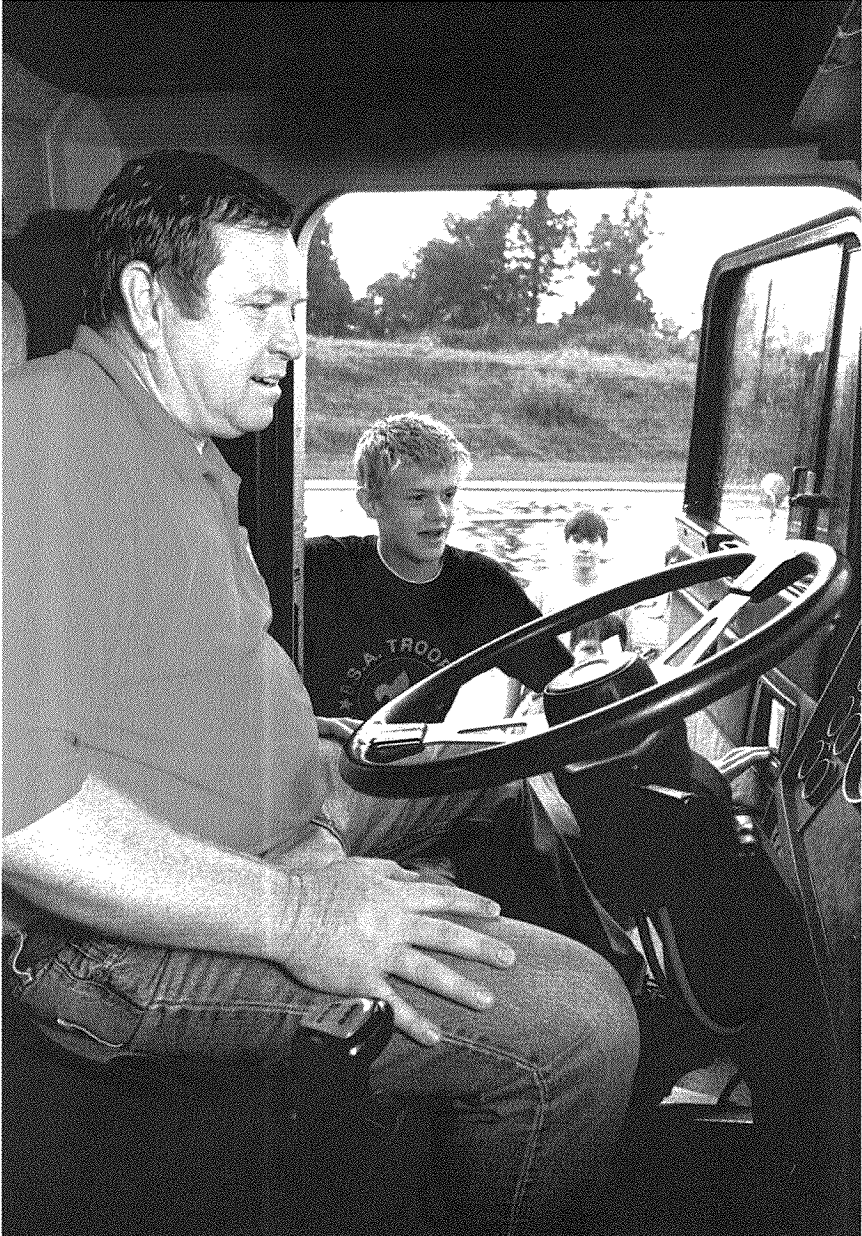

Careers in Truck Transportation

Truck transportation offers a variety of interesting careers, and the U.S. Department of Labor predicts that the number of positions in truck transportation will increase 10 percent by 2018. This means good career prospects for all positions within the industry, although most openings will be for drivers and diesel mechanics.

Here are some of the career opportunities in truck transportation. One of these positions might interest you.

Truck Driver

About 44 percent of all people employed in truck transportation are drivers, making it the industry's single largest occupation. Truck drivers not only pilot their trucks but also are responsible



In order to get their commercial driver's license, truck drivers need to be trained, too. If you have a knack for teaching others, you might want to think about becoming a commercial driving instructor.

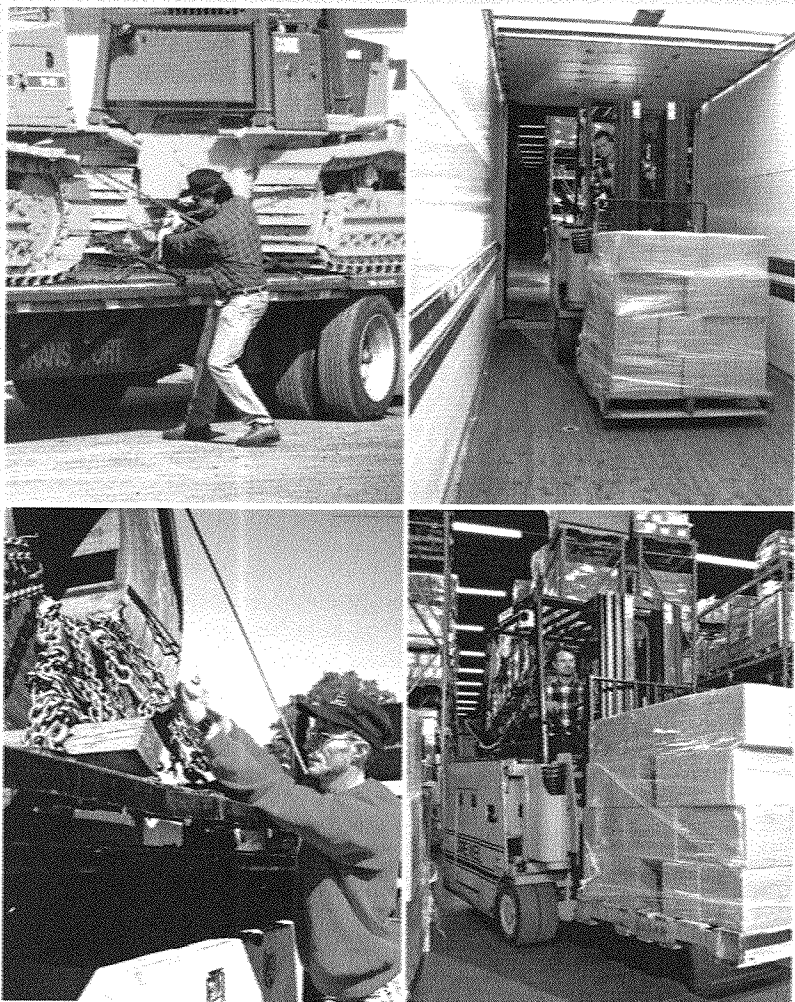

Some drivers must load and unload their own trucks.



Some over-the-road drivers have sleeper cabs that come with a bunk bed, refrigerator, and even TV.

for the truck's cargo and for making deliveries on time. Drivers have responsibility to other users of the road, too. They must always put safety first when driving.

Local truck drivers, often called city drivers, generally work about 50 hours per week. Most of them have regular routes and return home each night.

Long-distance truck drivers, or over-the-road drivers, are often on the road for long periods of time. Their trips can run from overnight to a stretch of a week or two. Many of these drivers are away from home for much of the year. Many long-distance drivers share the driving duties with a partner; these are called teams.

Before starting their route, by law, drivers must inspect their trucks thoroughly to ensure that everything is in proper working order. They make sure that the cargo on the truck is properly loaded to prevent damage. While driving, they must always be alert.

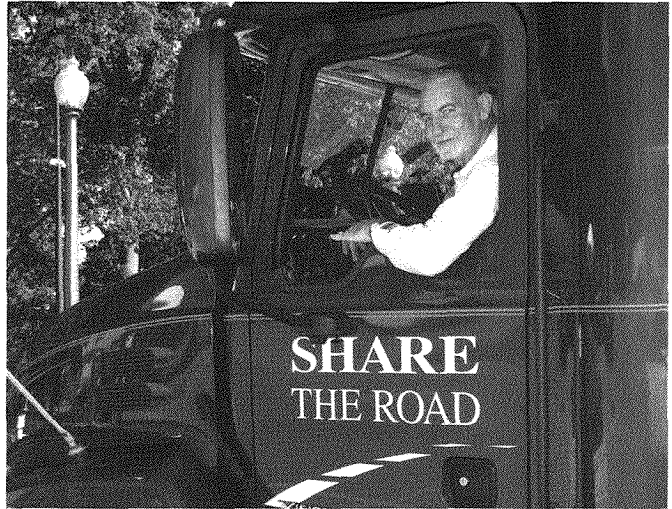

Truck drivers are paid well for their hard work. The average pay for a driver of a heavy truck is about \$18 per hour.

The U.S. Department of Transportation requires that truck drivers in interstate commerce be at least 21 years old. To drive a big truck (those that can carry more than 26,000 pounds of cargo), an operator must have a commercial driver's license, or CDL. Such drivers must pass a special test and have a safe driving record.

Sales Representative

The sales representative is responsible for finding new customers and for maintaining the accounts of customers who are already on the company's books. Sales representatives must understand all of the trucking company's services so they can describe and sell these services to customers. They must be familiar with prices, types of services offered, rules and regulations, and whether the company can meet the customers' needs. To match the trucking company's services with a customer's needs, the sales rep must also have an understanding of the customer's business.

Sales reps maintain regular contact with customers and help ensure that customers are satisfied with the carrier's service. They must be comfortable making presentations and speaking in front of groups of people. They also must be able to negotiate, or bargain, well. Part of their responsibility is to obtain the best or most competitive price they can for the company's services.

Dispatcher

Dispatchers are responsible for coordinating the carrier's trucks with the customers' freight. They tell drivers where the freight is and when it will be ready for pickup. Dispatchers give drivers their assignments, schedules, and routes.

Years ago, dispatchers communicated with their drivers by two-way radio—and this may still be the case with some very small trucking companies. But today, dispatchers at larger companies usually rely on mobile phones to keep in contact with their drivers. Quite a few companies use global positioning satellite (GPS) tracking systems, which allow dispatchers to pinpoint the location of their trucks and predict with some accuracy when a truck will reach its destination.

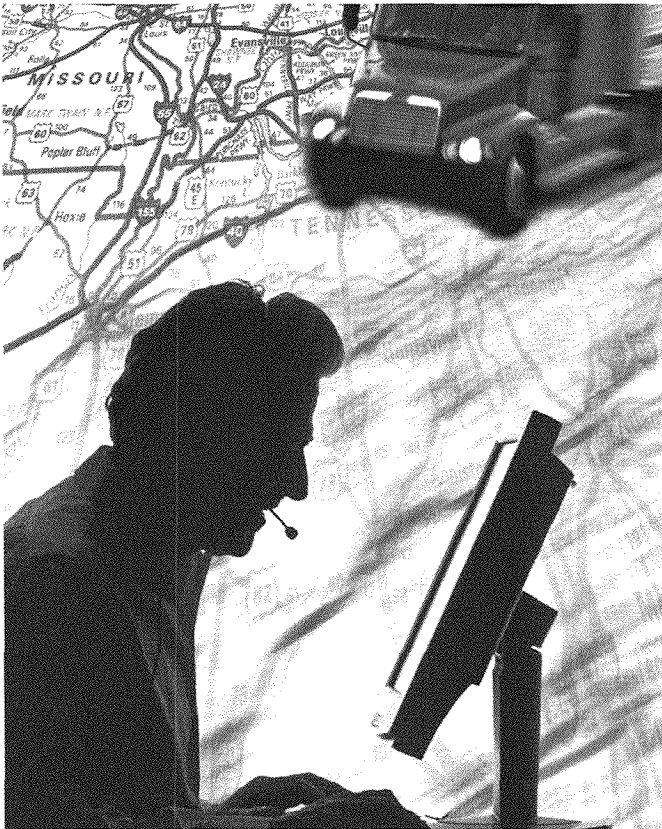

Trucking Terms

bill of lading. A shipping document that lists the goods in the shipment.

carrier. A trucking company.

cartage. The action of moving freight to and from an airport or seaport.

commerce. The movement of goods, funds, and information.

consignee. The company receiving a shipment.

container. A steel box, normally 20 to 40 feet long, used primarily in ocean freight transportation. Freight is stored inside the container, which is weathertight.

ETA. Estimated time of arrival; the time when a shipment should be delivered.

importation. The process of buying something from another country and bringing it to the United States.

intermodal. The practice of moving freight stowed in truck trailers or ocean containers via rail. This is also known as piggyback service, trailer-on-flat-car (TOFC), or container-on-flat-car (COFC).

internal combustion engine. An engine that produces power as a result of explosions occurring within the engine itself.

logbook. The book maintained by a truck driver showing the hours driven and the places the driver has been.

OS&D. Over, short, and damaged (goods). This is the claims department within a trucking company.

owner-operator. A very small trucking company where the owner of the company and the truck is also the driver.

piggyback. See *intermodal*.

raw materials. The things that go into making something else.

shipper. The company that gives freight to a trucker for transportation.

supply chain. The various companies involved in making something from the basic raw materials into the completed product, which is then available to the consumer.

tariff. A schedule of prices for transporting freight.

transportation mode. Means of transportation such as truck, air, rail, ship, or pipeline.

warehouse. A place where goods are stored.



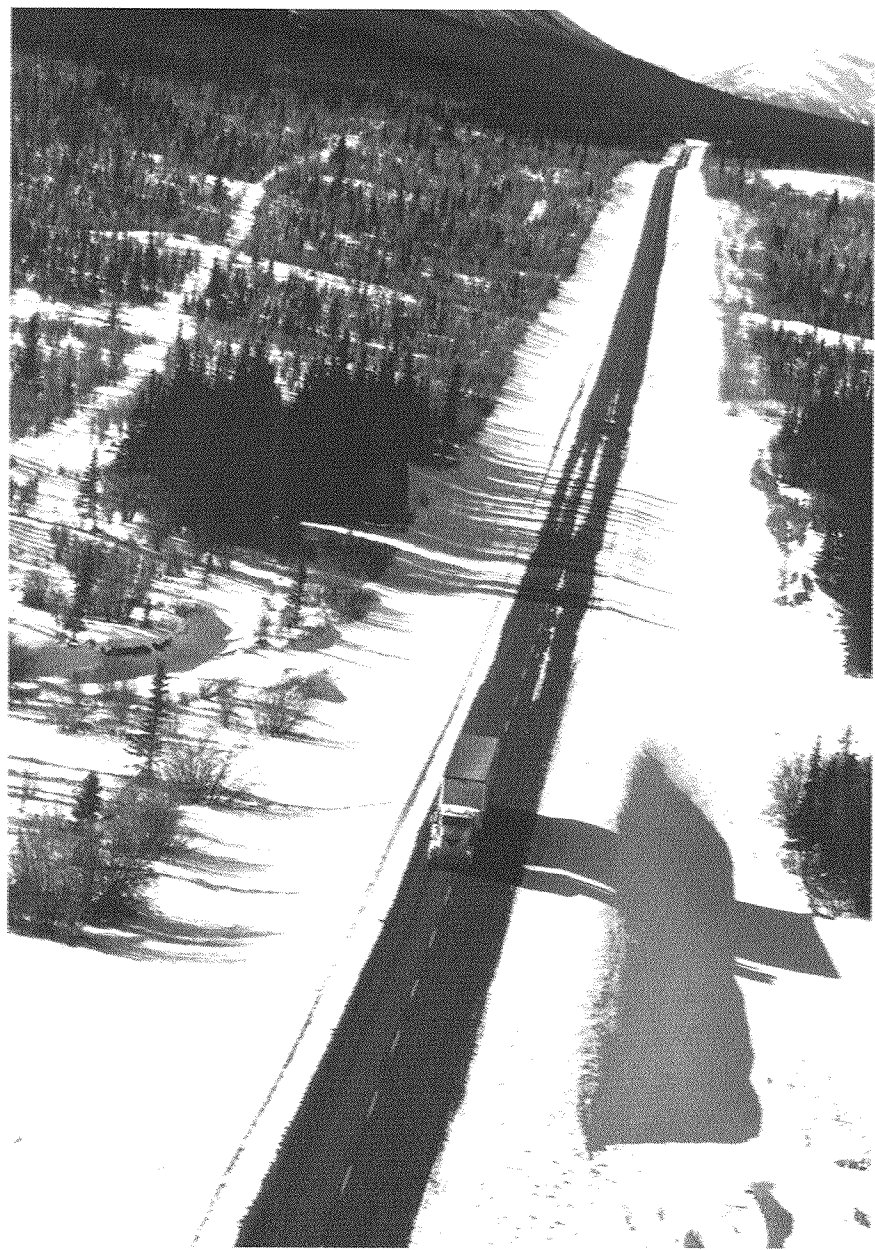

Truck Transportation Resources

Scouting Literature

Boy Scout Journal; American Business, Auto Mechanics, Aviation, Engineering, Railroad, and Traffic Safety merit badge pamphlets

Visit the Boy Scouts of America's official retail website at <http://www.scoutstuff.org> for a complete listing of all merit badge pamphlets and other helpful Scouting materials and supplies.

Books

- Byrnes, Mike, & Associates. *Bumper to Bumper: The Complete Guide to Tractor-Trailer Operations*. Mike Byrnes & Associates Inc., 2012.
- Ouellet, Lawrence J. *Pedal to the Metal: The Work Life of Truckers*. Temple University Press, 1994.
- Professional Truck Driver Institute. *Trucking: Tractor-Trailer Driver Handbook/Workbook*. Thomson Delmar Learning, 2006.
- Scharnberg, Ken. *Opportunities in Trucking Careers*. McGraw-Hill, 1999.

Woltman, Jeffrey J., and Sheena P. Woltman. *Trucking Simplified: Tools and Strategies for Running a Successful Trucking Operation*. Boogaloo Press, 2000.

Organizations and Websites

American Trucking Associations

950 N. Glebe Road, Suite 210
Arlington, VA 22203-4181
Telephone: 703-838-1700
Website: <http://www.truckline.com>

Federal Motor Carrier Safety Administration

1200 New Jersey Ave. SE
Washington, DC 20590
Toll-free telephone: 800-832-5660
Website: <http://www.fmcsa.dot.gov>

National Transportation Library

1200 New Jersey Ave. SE
Washington, DC 20590
Toll-free telephone: 800-853-1351
Website: <http://ntl.bts.gov>

U.S. Department of Transportation

1200 New Jersey Ave. SE
Washington, DC 20590
Telephone: 202-366-4000
Website: <http://www.dot.gov>

Acknowledgments

The Boy Scouts of America is grateful to Michael Stroh, the writer of this revised edition of the *Truck Transportation* merit badge pamphlet. A logistics practitioner since 1979, Mr. Stroh currently operates a consulting company called Logistics Network Inc. He is the author of *A Practical Guide to Transportation and Logistics*, a contributor to *Traffic World* magazine, and a member of the faculty of the Institute of Logistical Management and the World Trade Institute of Pace University.

Thanks also to George Downs and Mike Burner for their assistance with this revision. The BSA is grateful to the American Trucking Associations, in particular Elizabeth Barna and Joy Howells, for the use of many of the photos in this edition. We also are grateful to Pete Robinson of Jevic Transportation for the use of the company's photos.

We appreciate the assistance of Herman Fauss Jr., vice president of Safety Program Development for Landstar System Inc. Mr. Fauss is an active Scouter with the BSA's North Florida Council in Jacksonville.

The Boy Scouts of America is grateful to the men and women serving on the Merit Badge Maintenance Task Force for the improvements made in updating this pamphlet.

Photo and Illustration Credits

- American Trucking Associations, courtesy—pages 11 (*bottom*), 12 (*top*), 28, 31, 39–43 (*all*), and 45
- ©Comstock—page 29
- Ford Motor Company, courtesy—page 9
- HAAP Media Ltd., courtesy—cover (*both trucks*)
- Jevic Transportation Inc., courtesy—page 11 (*top*)
- ©Jupiterimages.com—pages 6 and 32
- ©Photos.com—cover (*sign*); pages 4, 22, and 46
- Shutterstock.com—pages 13 (114021064 ©kurhan), 26 (86103412 ©AISPIX by Image Source), and 20 (6488272 ©MSP photographic), 2013 Used under license from Shutterstock.com
- Wikipedia.org—page 41
- All other photos and illustrations not mentioned above are the property of or are protected by the Boy Scouts of America.
- Tom Copeland Jr.—page 13 (*bottom*)
- Daniel Giles—pages 17 (*top*), 18, 25, 27, 30, 34, 38, 43 (*left*), and 46
- John McDearmon—all illustrations on pages 15 and 19
- Brian Payne—cover (*air gun, bolts, wheel, engine, CB radio, steering wheel*); pages 7 and 12 (*bottom*)

MERIT BADGE LIBRARY

Though intended as an aid to Boy Scouts, Varsity Scouts, and qualified Venturers and Sea Scouts in meeting merit badge requirements, these pamphlets are of general interest and are made available by many schools and public libraries. The latest revision date of each pamphlet might not correspond with the copyright date shown below, because this list is corrected only once a year, in January. Any number of merit badge pamphlets may be revised throughout the year; others are simply reprinted until a revision becomes necessary.

If a Scout has already started working on a merit badge when a new edition for that pamphlet is introduced, *he may continue to use the same merit badge pamphlet to earn the badge and fulfill the requirements therein.* In other words, the Scout need not start over again with the new pamphlet and possibly revised requirements.

Merit Badge Pamphlet	Year	Merit Badge Pamphlet	Year	Merit Badge Pamphlet	Year
American Business	2013	Family Life	2016	Plant Science	2014
American Cultures	2013	Farm Mechanics	2014	Plumbing	2012
American Heritage	2013	Fingerprinting	2014	Pottery	2014
American Labor	2015	Fire Safety	2016	Programming	2013
Animal Science	2014	First Aid	2015	Public Health	2014
Animation	2015	Fish and Wildlife Management	2014	Public Speaking	2013
Archaeology	2014	Fishing	2013	Pulp and Paper	2013
Archery	2016	Fly-Fishing	2014	Radio	2013
Architecture and Landscape Architecture	2014	Forestry	2015	Railroading	2015
Art	2013	Game Design	2013	Reading	2013
Astronomy	2013	Gardening	2013	Reptile and Amphibian Study	2014
Athletics	2016	Genealogy	2013	Rifle Shooting	2012
Automotive Maintenance	2017	Geocaching	2010	Robotics	2016
Aviation	2014	Geology	2016	Rowing	2014
Backpacking	2016	Golf	2012	Safety	2015
Basketry	2014	Graphic Arts	2013	Salesmanship	2013
Bird Study	2013	Hiking	2016	Scholarship	2014
Bugling (see Music)		Home Repairs	2012	Scouting Heritage	2014
Camping	2016	Horsemanship	2013	Scuba Diving	2009
Canoeing	2014	Indian Lore	2011	Sculpture	2014
Chemistry	2011	Insect Study	2015	Search and Rescue	2012
Chess	2016	Inventing	2016	Shotgun Shooting	2013
Citizenship in the Community	2015	Journalism	2006	Signs, Signals, and Codes	2015
Citizenship in the Nation	2014	Kayaking	2016	Skating	2015
Citizenship in the World	2015	Landscape Architecture (see Architecture)		Small-Boat Sailing	2016
Climbing	2011	Law	2011	Snow Sports	2014
Coin Collecting	2008	Leatherwork	2013	Soil and Water Conservation	2016
Collections	2013	Lifesaving	2016	Space Exploration	2013
Communication	2013	Mammal Study	2014	Sports	2012
Composite Materials	2012	Medicine	2012	Stamp Collecting	2013
Cooking	2016	Metalwork	2012	Surveying	2004
Crime Prevention	2012	Mining in Society	2014	Sustainability	2013
Cycling	2013	Model Design and Building	2010	Swimming	2014
Dentistry	2016	Motorboating	2015	Textile	2014
Digital Technology	2013	Moviemaking	2013	Theater	2014
Disabilities Awareness	2016	Music and Bugling	2013	Traffic Safety	2016
Dog Care	2016	Nature	2014	Truck Transportation	2013
Drafting	2013	Nuclear Science	2010	Veterinary Medicine	2015
Electricity	2013	Oceanography	2012	Water Sports	2015
Electronics	2014	Orienteering	2012	Weather	2013
Emergency Preparedness	2015	Painting	2012	Welding	2016
Energy	2014	Personal Fitness	2016	Whitewater	2015
Engineering	2012	Personal Management	2015	Wilderness Survival	2012
Entrepreneurship	2013	Pets	2013	Wood Carving	2016
Environmental Science	2015	Photography	2016	Woodwork	2011
Exploration	2016	Pioneering	2017		

BOY SCOUTS OF AMERICA • SUPPLY GROUP

NATIONAL DISTRIBUTION CENTER

2109 Westinghouse Boulevard
P.O. Box 7143
Charlotte, NC 28241-7143

To place an order,
call customer service
toll-free 800-323-0736
or go to
www.scoutstuff.org



EAGLE SCOUT



FLORIDA SEA BASE

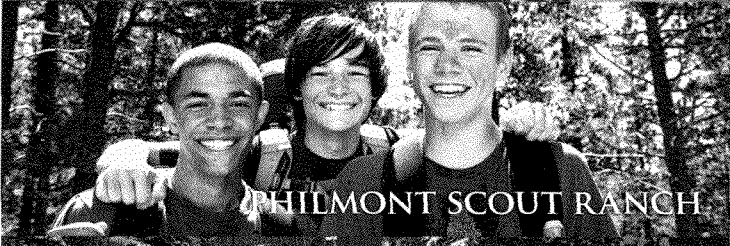

PHILMONT SCOUT RANCH

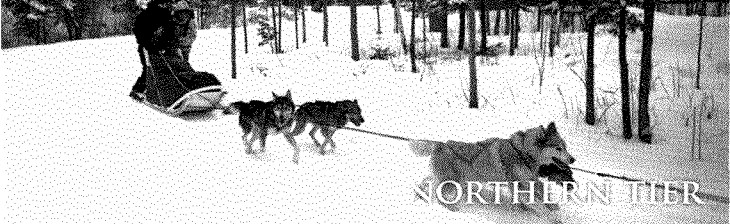

NORTHERN TIER

THE SUPPLY GROUP IS
READY TO BE A PARTNER
ON YOUR TRAIL TO
EAGLE THROUGH HIGH
ADVENTURE. THE
ADVENTURE IS YOURS.
AND WE ARE READY
WITH THE GEAR YOU
WILL NEED. YOU CAN
DEPEND ON THE LATEST
IN LIGHTWEIGHT,
DURABLE, QUALITY
GEAR THAT WILL
MEET AND SURPASS
YOUR TOUGHEST
REQUIREMENTS.



WWW.SCOUTSTUFF.ORG

SKU 35961



7 30176 35961 8 35961 2018 Printing

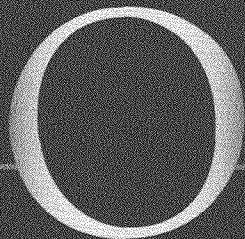

ON THE ROAD TO
HIGH ADVENTURE



Certified Sourcing
www.sfi-program.org
SF-00358