

MERIT BADGE SERIES

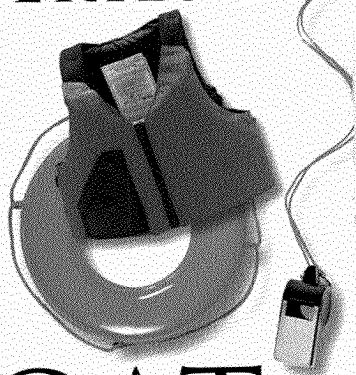

# SMALL-BOAT SAILING

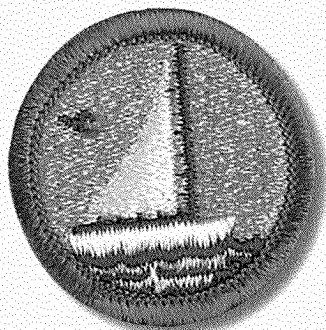
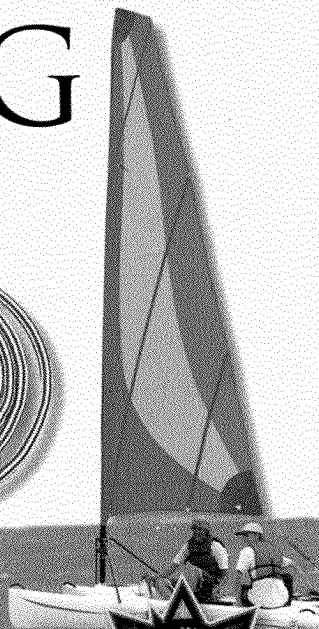
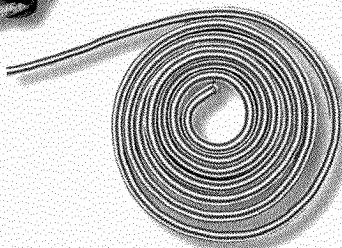
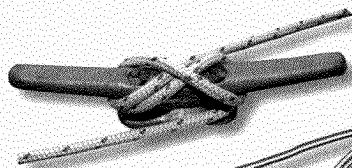

BOY SCOUTS OF AMERICA®



STEM-Based



## How to Use This Pamphlet

The secret to successfully earning a merit badge is for you to use both the pamphlet and the suggestions of your counselor.

Your counselor can be as important to you as a coach is to an athlete. Use all of the resources your counselor can make available to you. This may be the best chance you will have to learn about this particular subject. Make it count.

If you or your counselor feels that any information in this pamphlet is incorrect, please let us know. Please state your source of information.

Merit badge pamphlets are reprinted annually and requirements updated regularly. Your suggestions for improvement are welcome.

## Who Pays for This Pamphlet?

This merit badge pamphlet is one in a series of more than 100 covering all kinds of hobby and career subjects. It is made available for you to buy as a service of the national and local councils, Boy Scouts of America. The costs of the development, writing, and editing of the merit badge pamphlets are paid for by the Boy Scouts of America in order to bring you the best book at a reasonable price.

Send comments along with a brief statement about yourself to  
Pilots and Program Development, S272

Boy Scouts of America • 1325 West Walnut Hill Lane • Irving, TX 75038

If you prefer, you may send your comments to [merit.badge@Scouting.org](mailto:merit.badge@Scouting.org).

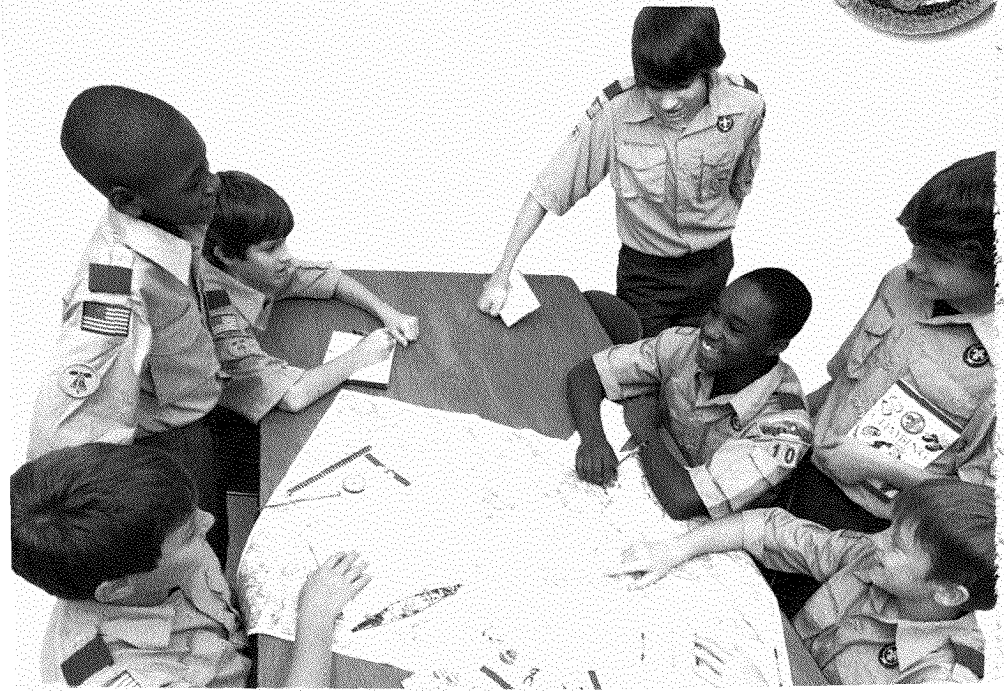
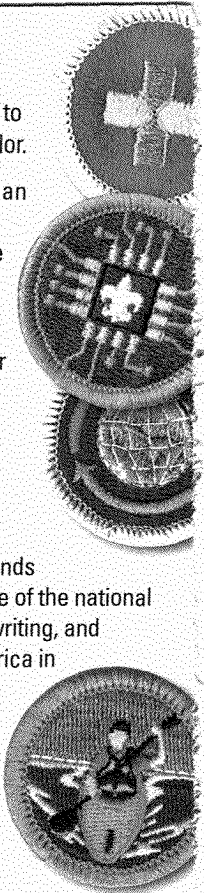

BOY SCOUTS OF AMERICA  
MERIT BADGE SERIES

# SMALL-BOAT SAILING

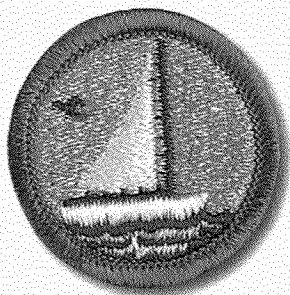

*"Enhancing our youths' competitive edge through merit badges"*



BOY SCOUTS OF AMERICA®

# Note to the Counselor

Merit badge counselors are responsible for following the requirements, procedures, and techniques presented in this pamphlet and for ensuring that each Scout earning the merit badge is able to demonstrate knowledge and skills at a level consistent with the requirements. In addition, counselors must ensure that all applicable BSA safety policies, including Safe Swim Defense and Safety Afloat, are followed during training, practice, and review.

Counselors for the Small-Boat Sailing merit badge must be registered members of the Boy Scouts of America, have current training in Safe Swim Defense and Safety Afloat, and be approved by the local council Advancement Committee. Councils with an Aquatics Committee should utilize that committee to coordinate with the Advancement Committee for approval of qualified counselors.

All counselors should have formal training in the knowledge and skills indicated by the requirements, experience in teaching such skills to youth, and experience in identifying and managing risks associated with the activities involved. For the Small-Boat Sailing merit badge, appropriate credentials include instructor certification with a recognized sailing agency or school, U.S. Sailing, or the American Sailing Association for sailing with different hull types including the rig being used for instruction. Counselors should also be familiar with the requirements for the Small-Boat Sailing merit badge and be able to perform the skills associated with each requirement. The council Advancement Committee may approve counselors with similar experience and training in knowledge, skill, safety, and instruction.



# Requirements

1. Do the following:
  - a. Explain to your counselor the most likely hazards you may encounter while participating in small-boat activities and what you should do to anticipate, help prevent, mitigate, and respond to these hazards.
  - b. Review prevention, symptoms, and first-aid treatment for the following injuries or illnesses that can occur while sailing: blisters, cold-water shock and hypothermia, dehydration, and heat-related illnesses, sunburn, sprains, and strains.
  - c. Discuss the BSA Safety Afloat policy. Tell how it applies to small-boat activities.
2. Before doing requirements 3 through 9, successfully complete the BSA swimmer test: Jump feetfirst into water over the head in depth. Level off and swim 75 yards in a strong manner using one or more of the following strokes: sidestroke, breaststroke, trudgen, or crawl; then swim 25 yards using an easy, resting backstroke. The 100 yards must be completed in one swim without stops and must include at least one sharp turn. After completing the swim, rest by floating.
3. Describe the boat you will be using for the sailing requirement, naming all of the major parts and the function of those parts.\*

\*The skills may be demonstrated on any boat available to the Scout; sailboards are not acceptable. While no specific sail plan is recommended, it is suggested that the craft be smaller than 20 feet. The boat must be capsizable and have the capability of sailing to windward.

4. Before going afloat, do the following:
  - a. Discuss the nine points of the BSA Safety Afloat plan.
  - b. Explain the rules of the road in general and any specific rules or laws that apply to your area or state.
  - c. Explain how water conditions, the hazards of weather, and heavy winds can affect both safety and performance in sailing.
  - d. Discuss the warning signs of inclement weather and what to do should heavy winds develop or a storm approach.
  - e. Prepare a typical float plan.
  - f. Discuss the proper clothing, footwear, and personal gear required for small-boat sailing in warm weather and in cool weather. Explain how choosing the proper clothing, footwear, and personal gear will help keep you comfortable and safe while sailing.
5. Discuss with your counselor how to identify the wind direction and wind indicators. Explain the importance of this task before setting sail.
6. Following the BSA Safety Afloat plan, show that you and a buddy can sail a boat properly. Do the following:
  - a. Prepare a boat for sailing, including a safety inspection.
  - b. Get under way from a dock, mooring, or beach.
  - c. Properly set sails for a round-trip course approved by your counselor that will include running, beating, and reaching—the basic points of sail. While sailing, demonstrate good helmsmanship skills.
  - d. Change direction by tacking; change direction by jibing.
  - e. Demonstrate getting out of irons.
  - f. Demonstrate the safety position.
  - g. Demonstrate capsize procedures and the rescue of a person overboard.†

†Capsize procedures should be conducted under the close supervision of the counselor. A rescue boat should be standing by to assist, if necessary, and to tow the capsized craft to shore. Self-bailing boats are acceptable for this requirement. Extreme care should be taken to avoid personal injury and damage to the boat or equipment.

- h. Demonstrate the procedure to take after running aground.
  - i. Upon returning to the dock, mooring, or beach, properly secure all equipment, furl or stow sails, and prepare the craft for unattended docking or beaching overnight or longer.
7. Demonstrate a working knowledge of marlinespike seamanship. Do the following:
    - a. Show how to tie a square (reef) knot, clove hitch, two half hitches, bowline, cleat hitch, and figure-eight knot. Demonstrate the use of each.
    - b. Show how to heave a line, coil a line, and fake down a line.
    - c. Discuss the kinds of lines used on sailboats and the types of fibers used in their manufacture. Explain the advantages and disadvantages of each.
  8. Describe how you would care for and maintain a sailboat and its gear throughout the year.
  9. With your counselor, review sailing terminology and the points of sail. Discuss various types of sailboats in use today and explain their differences.

## Contents

Sailing Safety and Preparation . . . . .	7
Sailboat Basics . . . . .	23
Wind . . . . .	33
Getting Under Way . . . . .	39
Sailing Fundamentals . . . . .	47
Marlinespike Seamanship . . . . .	63
Rules of the Road . . . . .	70
Emergencies . . . . .	75
Maintenance . . . . .	83
History of Sailing in America . . . . .	89
Small-Boat Sailing Resources . . . . .	93

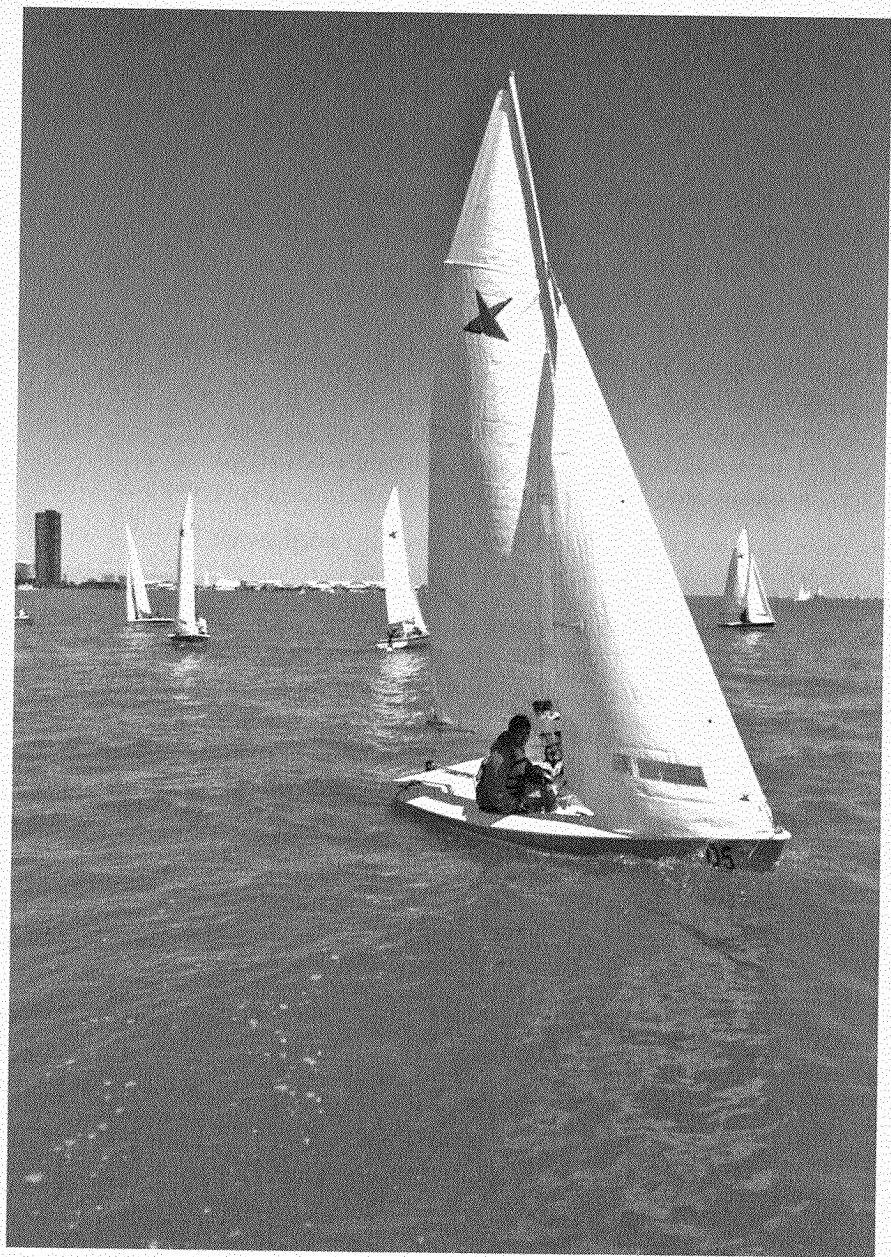

# Sailing Safety and Preparation

Sailing is an enjoyable pastime. The serenity of the water can make you feel as though you have escaped from everyday life. However, smooth sailing requires paying careful attention to safety.

## BSA Safety Afloat

When earning any of the aquatic merit badges, it is important to follow safety rules and use self-discipline and good judgment. Small-boat sailing will be among the most memorable of your Scouting experiences if you understand and follow the points of Safety Afloat. These guidelines were developed to promote boating safety and to set standards for safe unit activity afloat. They apply to all sailing activities.

**1. Qualified Supervision.** All activity afloat must be supervised by a mature and conscientious adult age 21 or older who understands and knowingly accepts responsibility for the well-being and safety of those in his or her care and who is trained in and committed to compliance with the nine points of BSA Safety Afloat. That supervisor must be skilled in the safe operation of the craft for the specific activity, knowledgeable in accident prevention, and prepared for emergency situations. If the adult with Safety Afloat training lacks the necessary boat operating and safety skills, then he or she may serve as the supervisor only if assisted by other adults, camp staff personnel, or professional tour guides who have the appropriate skills. Additional leadership is provided in ratios of one trained adult, staff member, or guide per 10 participants. For Cub Scouts, the leadership ratio is one trained adult, staff member, or guide per five participants. At least one leader must be trained in first aid including CPR.

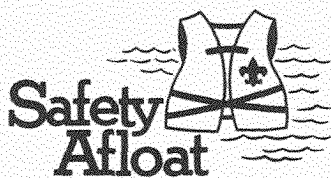

---

The complete text of Safety Afloat can be found in the BSA's *Guide to Safe Scouting*, which can be found at [www.scouting.org/health-and-safety/gss](http://www.scouting.org/health-and-safety/gss).

---



Use sunscreen with a sun protection factor (SPF) of at least 15. Sunglasses, a wide-brimmed hat, long-sleeved shirt, and lip balm with an SPF of at least 15 will give you further protection from the sun.

---

Any swimming done in conjunction with the activity afloat must be supervised in accordance with BSA Safe Swim Defense standards. It is strongly recommended that all units have at least one adult or older youth member currently trained in BSA Aquatics Supervision: Paddle Craft Safety to assist in the planning and conduct of all activities afloat.

**2. Personal Health Review.** A complete health history is required of all participants as evidence of fitness for boating activities. Forms for minors must be signed by a parent or legal guardian. Participants should be asked to relate any recent incidents of illness or injury just prior to the activity. Supervision and protection should be adjusted to anticipate any potential risks associated with individual health conditions. For significant health conditions, the adult supervisor should require an examination by a physician and consult with a parent, guardian, or caregiver for appropriate precautions.

**3. Swimming Ability.** Operation of any boat on a float trip is limited to youth and adults who have completed the BSA swimmer classification test. Swimmers must complete the following test, which must be administered annually.

Jump feetfirst into water over the head in depth. Level off and swim 75 yards in a strong manner using one or more of the following strokes: sidestroke, breaststroke, trudgen, or crawl; then swim 25 yards using an easy, resting backstroke. The 100 yards must be completed in one swim without stops and must include at least one sharp turn. After completing the swim, rest by floating.

- For activity afloat, those not classified as a swimmer are limited to multiperson craft during outings or float trips on calm water with little likelihood of capsizing or falling overboard. They may operate a fixed-seat rowboat or pedal boat accompanied by a buddy who is a swimmer. They may paddle or ride in a canoe or other paddle craft with an adult swimmer skilled in that craft as a buddy. They may ride as part of a group on a motorboat or sailboat operated by a skilled adult.

**4. Life Jackets.** Properly fitted U.S. Coast Guard-approved life jackets must be worn by all persons engaged in boating activity (rowing, canoeing, sailing, boardsailing, motorboating, waterskiing, rafting, tubing, and kayaking). Type III life jackets are recommended for general recreational use.

- For vessels over 20 feet in length, life jackets need not be worn when participants are below deck or on deck when the qualified supervisor aboard the vessel determines that it is prudent to abide by less-restrictive state and federal regulations concerning the use and storage of life jackets, for example, when a cruising vessel with safety rails is at anchor. All participants not classified as swimmers must wear a life jacket when on deck underway.
- Life jackets need not be worn when an activity falls under Safe Swim Defense guidelines—for example, when an inflated raft is used in a pool or when snorkeling from an anchored craft.

**5. Buddy System.** All participants in an activity afloat are paired as buddies who are always aware of each other's situation and prepared to sound an alarm and lend assistance immediately when needed. When several craft are used on a float trip, each boat on the water should have a "buddy boat." All buddy pairs must be accounted for at regular intervals during the activity and checked off the water by the qualified supervisor when the activity is over. Buddies either ride in the same boat or stay near each other when riding in single-person craft.

**6. Skill Proficiency.** Everyone in an activity afloat must have sufficient knowledge and skill to participate safely. Passengers should know how their movement affects boat stability and have a basic understanding of self-rescue. Boat operators must meet government requirements, be able to maintain control of their craft, know how changes in the environment influence that control, and only undertake activities within personal and group capabilities.

- Content of training exercises should be appropriate for the age, size, and experience of the participants, and should cover basic skills on calm water of limited extent before proceeding to advanced skills involving current, waves, high winds, or extended distance. At a minimum, instructors for canoes and kayaks should be able to demonstrate the handling and rescue skills required for BSA Aquatics Supervision: Paddle Craft Safety. All instructors must have at least one assistant who can recognize and respond appropriately if the instructor's safety is compromised.
- Anyone engaged in recreational boating using human-powered craft on flatwater ponds or controlled lake areas free of conflicting activities should be instructed in basic safety

procedures prior to launch, and allowed to proceed after they have demonstrated the ability to control the boat adequately to return to shore at will.

- For recreational sailing, at least one person aboard should be able to demonstrate basic sailing proficiency (tacking, reaching, and running) sufficient to return the boat to the launch point. Extended cruising on a large sailboat requires either a professional captain or an adult with sufficient experience to qualify as a bareboat skipper.
- Motorboats may be operated by youth, subject to state requirements, only when accompanied in the boat by an experienced leader or camp staff member who meets state requirements for motorboat operation. Extended cruising on a large power boat requires either a professional captain or an adult with similar qualifications.
- Before a unit using human-powered craft controlled by youth embarks on a float trip or excursion that covers an extended distance or lasts longer than four hours, each participant should either receive a minimum of three hours training and supervised practice or demonstrate proficiency in maneuvering the craft effectively over a 100-yard course and recovering from a capsize.
- Self-guided unit trips on Class III whitewater may only be done after all participants have received American Canoe Association or equivalent training for the class of water and type of craft involved. Unit trips on whitewater sections of rivers rated Class IV are only allowed in rafts with a professionally trained guide in each raft. Trips above Class IV are not allowed.

**7. Planning.** Proper planning is necessary to ensure a safe, enjoyable exercise afloat. All plans should include a scheduled itinerary, notification of appropriate parties, communication arrangements, contingencies in case of bad weather or equipment failure, and emergency response options.

- **Preparation.** Any boating activity requires access to the proper equipment and transportation of gear and participants to the site. Determine what state and local regulations are applicable. Get permission to use or cross private property. Determine whether personal resources will be used or whether outfitters will supply equipment, food, and shuttle services. Lists of group and personal equipment

and supplies must be compiled and checked. Even short trips require selecting a route, checking water levels, and determining alternative pull-out locations. Changes in water level, especially on moving water, may pose significant, variable safety concerns. Obtain current charts and information about the waterway and consult those who have traveled the route recently.

- **Float Plan.** Complete the preparation by writing a detailed itinerary, or float plan, noting put-in and pull-out locations and waypoints, along with the approximate time the group should arrive at each. Estimate your travel time generously.
- **Notification.** File the float plan with parents, the local council office if traveling on running water, and local authorities if appropriate. Assign a member of the unit committee to alert authorities if prearranged check-ins are overdue. Make sure everyone is promptly notified when you return from the trip.
- **Weather.** Check the forecast just before setting out, and keep an alert weather eye. Anticipate changes and bring all craft ashore when rough weather threatens. Wait at least 30 minutes before resuming activities after the last incidence of thunder or lightning.
- **Contingencies.** Planning must identify possible emergencies and other circumstances that could force a change of plans. Develop alternative plans for each situation. Identify local emergency resources such as EMS systems, sheriff's departments, or ranger stations. Check your primary communication system, and identify backups, such as the nearest residence to a campsite. Cell phones and radios may lose coverage, run out of power, or suffer water damage.

**8. Equipment.** All craft must be suitable for the activity, be seaworthy, and float if capsized. All craft and equipment must meet regulatory standards, be properly sized, and be in good repair. Spares, repair materials, and emergency gear must be carried as appropriate. Life jackets and paddles must be sized to the participants. Properly designed and fitted helmets must be worn when running rapids rated Class II and above. Emergency equipment such as throw bags, signal devices, flashlights, heat sources, first-aid kits, radios, and maps must be ready for use. Spare equipment, repair materials, extra food and water, and dry clothes should be appropriate for the activity. All gear should be stowed to prevent loss and water damage. For

float trips with multiple craft, the number of craft should be sufficient to carry the party if a boat is disabled, and critical supplies should be divided among the craft.

**9. Discipline.** Rules are effective only when followed. All participants should know, understand, and respect the rules and procedures for safe boating activities provided by Safety Afloat guidelines. Applicable rules should be discussed prior to the outing and reviewed for all participants near the boarding area just before the activity afloat begins. People are more likely to follow directions when they know the reasons for rules and procedures. Consistent, impartially applied rules supported by skill and good judgment provide stepping-stones to a safe, enjoyable outing.

## First Aid

When you are the skipper of a boat, you are responsible for the safety of all those on board. If someone becomes ill or gets hurt while on the water, getting medical help might take some time. You have to be prepared to handle minor injuries and possible medical emergencies until help is available.

*Hypothermia* is a condition in which the body loses heat faster than it can create it, and the victim starts to feel cold. There are a number of stages of hypothermia, beginning with shivering and chattering teeth, then leading to finger and toe numbness, mental confusion, loss of consciousness, and, in extreme cases, death.

To treat hypothermia, move the victim to a warm, dry area. If this is not possible, try to shield the victim from wind, rain, and spray. Remove wet clothing. Wrap the person in layers of dry clothing, blankets, or towels. If the victim is conscious, offer warm liquids to drink, but only if the victim can swallow comfortably.

To avoid hypothermia, participants need to stay dry and well-insulated from cold and wind chill. Dressing properly for the weather can prevent hypothermia.

When a person's body cannot cool itself sufficiently on a hot, sunny day, *heat exhaustion* could occur, causing the victim to feel faint. Early symptoms of heat exhaustion include heavy sweating, reddening of the skin, headache, fatigue, difficulty concentrating, and possible loss of consciousness.

Heat exhaustion can lead to *heatstroke*, which is very serious. Sweating, which is the body's natural protection from



overheating, may stop entirely as the body *dehydrates* (dries out) and begins to shut down. Loss of consciousness soon follows. To treat heatstroke, sponge the person with cool water. Get medical help immediately. If not treated promptly, the victim could die.

To prevent heat emergencies, drink plenty of fluids, wear a hat and sunglasses, and apply a sunscreen with an SPF of 15 or higher. Avoid unnecessary direct sun exposure, and limit strenuous physical activity.

*Motion sickness* (called *seasickness* on boats) can happen to anyone, although some people are more prone to it than others. The rougher the sea conditions, the more likely it is to occur. Motion sickness causes victims to feel sick to their stomachs and can lead to vomiting. It helps if a seasick victim remains in fresh air and stares at the horizon. The worst place to be is down below in an enclosed cabin. Motion sickness can make a person feel miserable, but it normally is not life-threatening. Comfort the victim as much as possible until you can get to shore or smoother waters. The nausea goes away quickly after the motion stops.

Applying an ice pack to a *contusion*, or bruise, will reduce pain and swelling. Cuts, scratches, abrasions, and puncture wounds can all lead to infection if not cleaned and bandaged properly with a sterile dressing. Minor wounds can be washed carefully with soap and water and bandaged. Deeper cuts or puncture wounds may need stitches, antibiotics, and a tetanus shot to prevent infection. Return to shore at once and visit a doctor.

If a wound bleeds, press a clean cloth or bandage to the area until the bleeding stops. If the bleeding does not stop in a few minutes, get medical attention.

*Blisters* can occur from continuous rubbing (such as from a shoe or handling sheets or lines), burns, or allergic reactions

---

Frightened or anxious victims might breathe too heavily or too deeply, which can result in *hyperventilation*. Calmly encourage the person to relax and breathe slowly.

---

**Cardiopulmonary resuscitation (CPR)** is the important first response in the event of cardiac emergency, and such emergencies can occur as the result of any strenuous activity. CPR is used in drowning accidents when submersion has caused respiratory and cardiac arrest, and individuals trained in CPR should be included in every aquatic outing. Complete CPR should be attempted only by people qualified by practice under supervision of a trained instructor. The *Boy Scout Handbook* and the *First Aid* merit badge pamphlet explain CPR and when it should be used.



TYPE I

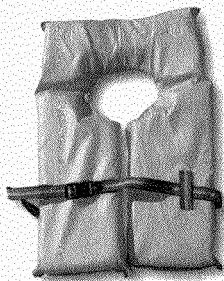

TYPE II



TYPE III

### Life jackets

(such as from poison ivy). Avoid breaking a blister. Doing so can lead to infection. Instead, cover and protect that area of the skin from further damage. Most blisters will shrink and disappear on their own. If you have any doubt, see a doctor.

### Required Equipment

The U.S. Coast Guard requires that every vessel carry certain safety equipment while under way. Some states also require that boat operators take an approved boating safety course and carry an operator's certificate. Many states require small boats to be registered and to display numbers on the hull. Other states exempt small sailboats from registration if they do not have motors.

Life jackets are required in every state and on every vessel, no matter how big or small. Every person on board is required to have one. Roughly 90 percent of all boating fatalities result from drowning. Most drowning victims were not wearing a life jacket. BSA policy requires that everyone wear a life jacket when on the open water in a small boat.

A life jacket is a wearable personal flotation device and is available in a variety of sizes and designs. The law requires that the life jacket must be the correct size for the person who wears it. It must be in serviceable condition, and it must be approved by the U.S. Coast Guard. The USCG also specifies that any sailboat

**You can tell if a life jacket meets USCG standards by looking for a USCG approval number on it.**

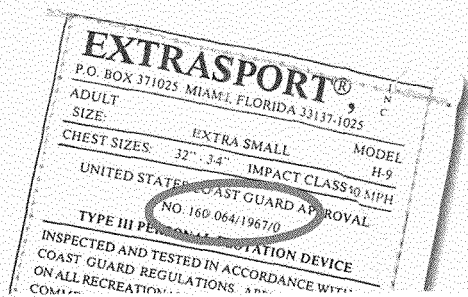

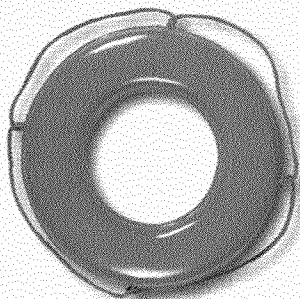

**Throwable flotation devices also must be USCG-approved and in good condition.**

16 feet or longer must carry a Type IV throwable flotation device on board, in addition to a life jacket for each passenger. A throwable device, such as a cushion or life ring, provides immediate emergency buoyancy to an overboard victim.

If you find yourself sailing in low-visibility conditions, such as fog, you will need a horn. You are required to alert other vessels of your presence by sounding one long blast and two short blasts. The law requires that boats shorter than 26 feet sound the horn for three to five seconds. The horn should be loud enough to be heard at least one-half mile away. Bigger boats need louder horns that can be heard at least one mile away.

Sailing a small sailboat at night is not a good idea. However, if you do find yourself out after dark, you must have a light. A small sailboat without a motor must display a white light at night in time to prevent a collision. A flashlight will do. Shining it on your sail to reflect the light is a good way to get the attention of other vessels so they will not accidentally hit you. For suggested additional equipment, see the preparation checklist in the "Getting Under Way" chapter.

All boaters have the responsibility to learn and follow the rules of their state and of the U.S. Coast Guard. Contact your police department's marine division or your state boating law administrator's office for full details on requirements in your area.

---

## Weather and Water Conditions

Remember this  
sailor's maxim:  
When in doubt,  
don't go out.

---

The speed of the wind determines how much power the sails have to work with. Gentler winds, which sailors call *light air*, make sailing slow, peaceful, and relaxing. Medium wind speeds are often the most fun for sailors. Higher winds, or *heavy air*, can be dangerous for unprepared or inexperienced sailors.

Wise sailors do not leave land without first checking the weather forecast. Perhaps the most important item in the forecast is the predicted wind speed. You cannot control the speed of the wind, but you can be prepared for it.

If the wind is too strong for your skill level, it could be dangerous. Strong wind and rough seas can swamp boats or cause them to *capsize*, or overturn. Small boats are particularly vulnerable. Always check the weather forecast before you go sailing. If in doubt, do not go out.

When a thunderstorm passes over water, sailors call it a *squall*. Severe squalls can bring heavy rain, lightning, hail, and damaging winds. Wind gusts can reach hurricane velocity. A squall is a serious threat to any small boat, especially a sailboat. If you see dark clouds rising in the sky and hear thunder rumbling in the distance, head to the safety of the harbor immediately.

If you cannot make it to safety before a squall strikes:

- Lower your sails so you do not capsize in a gust.
- Anchor to hold your position and to keep the bow aimed into the wind.
- Stay low and in the center of the boat to maximize its stability.
- Do not hold the mast or any standing rigging that might be struck by lightning.
- Double-check your life jacket. Be sure it is fastened and adjusted properly.
- Remain calm and ride it out. Squalls often blow over in a few minutes.
- Stay with the boat if you capsize.

A plastic or other nonrusting whistle attached to your life jacket (not around your neck) makes an excellent emergency signaling device. Attach it with a stainless steel cotter ring (split ring) or a plastic cable tie.



Wind speed in marine weather forecasts is often given in *knots*—nautical miles per hour. While a statute mile—5,280 feet—measures distance on land, a nautical mile—6,076 feet or 1.15 statute miles—measures distance at sea. The difference in length is the equivalent of more than two and a half football fields. Because of this length difference, a nautical mile per hour is 15 percent faster than a statute mile per hour.

## Evaluating Wind Speeds

- Wind speeds of 5 to 15 miles per hour generally are safe and fun for all qualified sailors.
- When wind speeds exceed 15 miles per hour (steady), it is time to be very careful if you do not have much sailing experience. Wait for the breeze to calm down.
- When wind speed is likely to reach 20 miles per hour, small-craft advisories may be posted. The water can be quite choppy and dangerous for smaller boats and beginner sailors.
- When wind speeds are above 25 miles per hour, all small sailboats struggle for control, including those sailed by experts. The risk of capsizing is high. It is best to stay on shore and wait for the wind to decrease.

Foul-weather warnings are indicated by colored flags or lights as indicated. These warning signs might not be displayed in your area, so check for local usage.

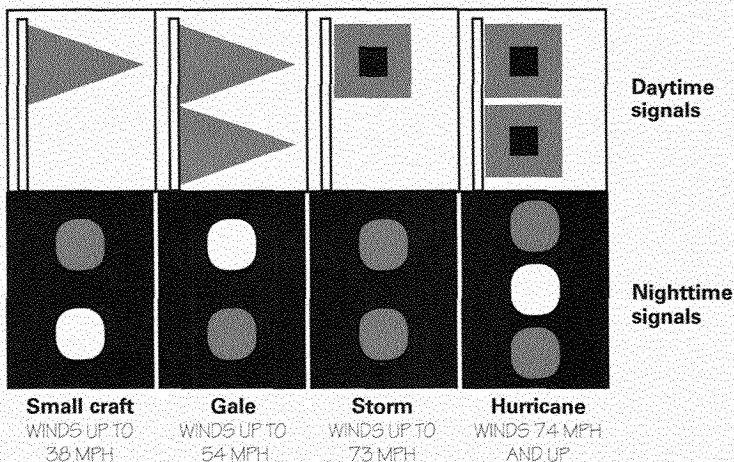



## It's in the Clouds

Weather systems primarily move from west to east. By keeping a close eye on the western sky, you can often get an idea of what weather to expect. Clouds indicate the atmosphere's stability at different altitudes and can warn of what weather is likely.

- A** **Cirrostratus**—If these clouds thicken, there will be rain in six to 24 hours. If they cover the whole sky, a warm front or storm is near.
- B** **Altostratus**—When thickening, these clouds indicate a warm front or storm.
- C** **Stratocumulus**—When these clouds become dense, expect rain. If they form after showers, weather will clear.
- D** **Cumulus**—If these clouds mass to windward (the direction from which the wind is blowing) they foretell a storm. If they grow larger on a summer day, there will be a thunderstorm. In small, widely separated patches, they mean fair weather.

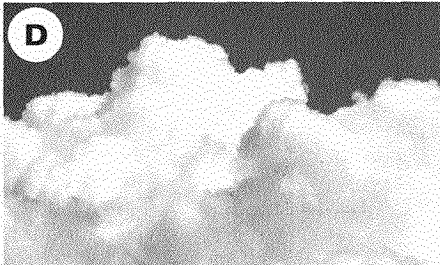
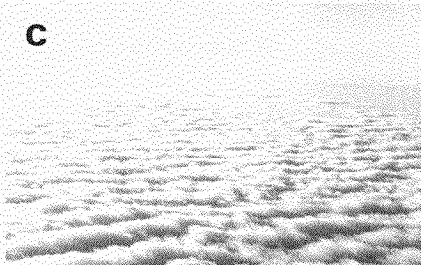

**E Cirrus**—Expect fair weather when these clouds drift idly, stand still, or dissolve as the sun climbs. If they increase, rain or foul weather is ahead.

**F Cirrocumulus**—These clouds indicate the approach of a weak disturbance, or, if the clouds are increasing in density, rain within 24 hours.

**G Altocumulus**—In small, isolated patches, or if decreasing, these clouds mean fair weather. If they are piled up into domes, beware of thunderstorms.

**H Cumulonimbus**—These are thunderstorm clouds and generally produce heavy showers of rain, snow, or hail.

**I Stratus**—These clouds indicate light, steady rain.

Clouds may tell only what you can expect in the immediate future. Weather forecasts (from TV, radio, the Internet) will give you a more extended prediction of approaching weather. Before leaving shore, always get an up-to-the-minute forecast. Use clouds for confirmation, and carry a radio on board for regular weather updates.

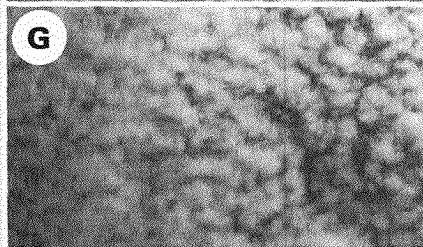
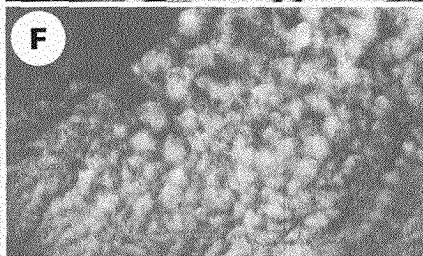

Once you have filed a float plan, stick to it. If you sail off in the opposite direction from where your float plan indicated and you get into trouble, searchers will look for you in the wrong location.

## Preparing a Float Plan

Before going out on the water on any boat, leave a copy of your float plan with a reliable friend or family member—someone who will take action if you are overdue or if he or she suspects trouble. A float plan contains the information searchers or rescuers need to know in an emergency, such as departure and estimated arrival times, planned route, anticipated stops along the way, and the names and number of passengers.

For longer voyages, a float plan should be in a structured written form like the one below. For brief day sails close to shore, it can be as simple as describing your plans to your parents. Written float plans are always better, however, because they do not rely on anyone's memory.

### Sample Float Plan

Float plan of \_\_\_\_\_

Destination \_\_\_\_\_

Date and time of departure \_\_\_\_\_

Date and time of return \_\_\_\_\_

Boat name and number \_\_\_\_\_

Description of boat \_\_\_\_\_

Planned route, going and returning \_\_\_\_\_  
\_\_\_\_\_

Others who will go along \_\_\_\_\_

Equipment \_\_\_\_\_

Clothing \_\_\_\_\_

Weather \_\_\_\_\_

In emergency, contact \_\_\_\_\_

## What to Wear

If the weather is warm enough, shorts are ideal clothing for sailing because they allow you to easily bend at the knee. Being able to move around freely is essential in small-boat sailing.

If temperatures are cool, layering is the key to keeping warm, dry, and safe. You might start layering with a T-shirt, followed by a sweatshirt or a fleece vest, and then a sprayproof windbreaker or hooded parka. As the day warms up, you can remove layers. Later, if the wind picks up and it gets cooler, you can add back as many layers as you need for comfort.

Perhaps the most common injuries on sailboats are foot injuries. To avoid foot injuries, wear proper shoes. Boat shoes should have nonskid soles and should enclose and protect the toes and heels. They should be well-secured with laces or straps—sandals are not appropriate footwear on sailboats.

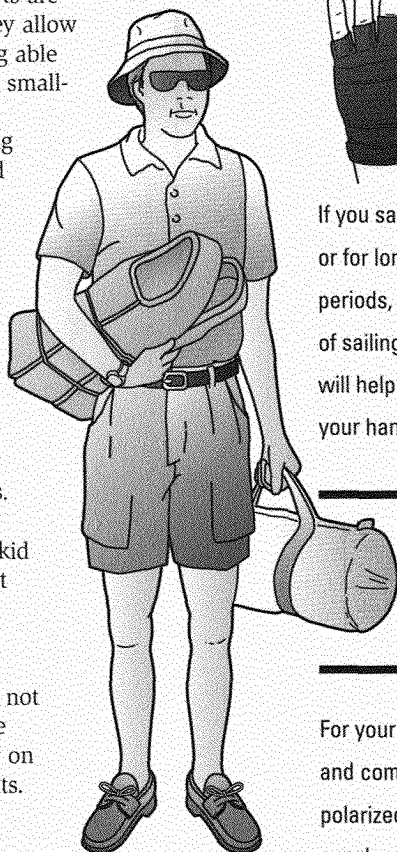
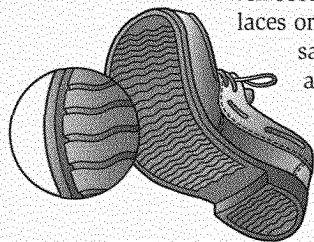

If you sail often or for long periods, a pair of sailing gloves will help protect your hands.

For your safety and comfort, polarized sunglasses with UV protection are recommended under sunny conditions. Secure all eyeglasses with a strap.



Always keep your life jacket on the outside of all clothing. Adjust the straps to accommodate your added or removed layers. A small duffel bag is handy to stow and protect your spare clothes and personal gear.

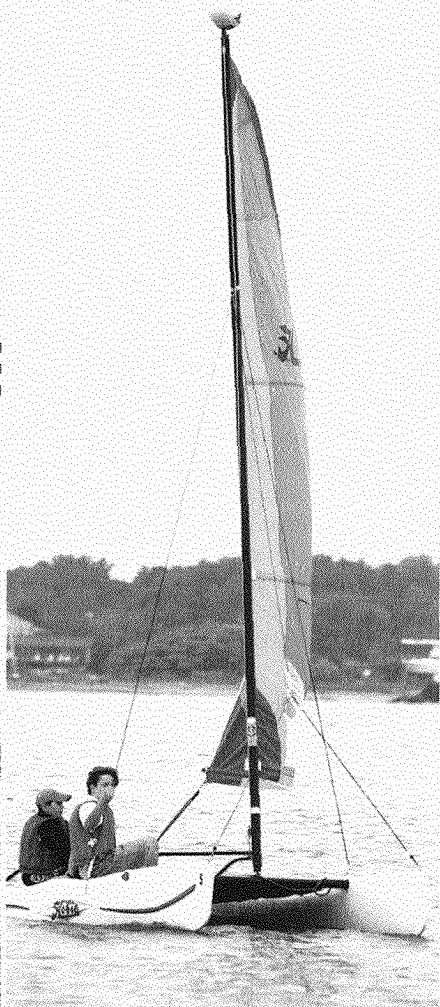

Sailboats may have one or more hulls. A single-hulled boat is called a monohull, while boats with more than one hull are multihulls. The most common small multihull is a catamaran. Catamarans have two hulls and are known for their speed, but they are not as maneuverable as monohulls.



# Sailboat Basics

A sailboat transfers energy from the wind through its sails to propel the boat. Sailboats come in many shapes and sizes, but nearly every sailboat has five essential parts: the *hull*, *hulls*, *spars*, *rigging*, and *sails*.

## Hull

The hull is the central floating body of the boat—the part you sit in. All other parts are attached to it.

A hull has a number of parts, each with its own name. The *bow* is the front of the hull. The *stern* is the back. The *cockpit* is where you sit inside the hull. A *deck* may partially cover the top of the hull to help keep water out. The *gunwale* (pronounced gun'-nul) is the outside edge of the deck, where it touches the *topsid*s. The *topsid*s are the sides of the hull that extend down to the *chine*, the edge where the hull's bottom and *topsid*s join together. The *transom* is the flat outside portion of the stern.

Sailors use seafaring terms to describe direction. For example, instead of using "right" and "left" to distinguish the two sides of a hull, sailors use the terms *starboard* and *port*. Looking forward, the right side of a hull is the starboard side, and the left side is the port side. The terms *fore* and *aft* refer to things that are ahead (before) or behind (after).

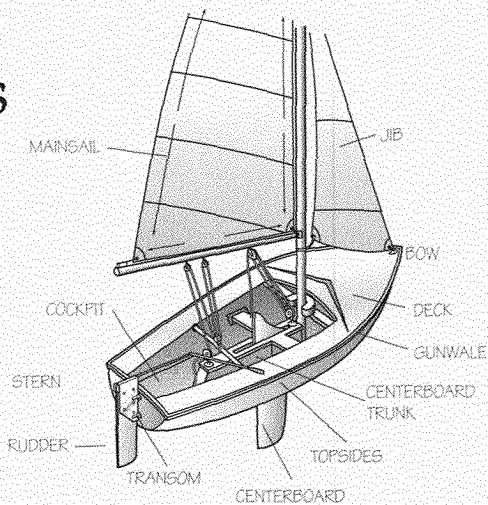

**Typical sailboat with a centerboard**

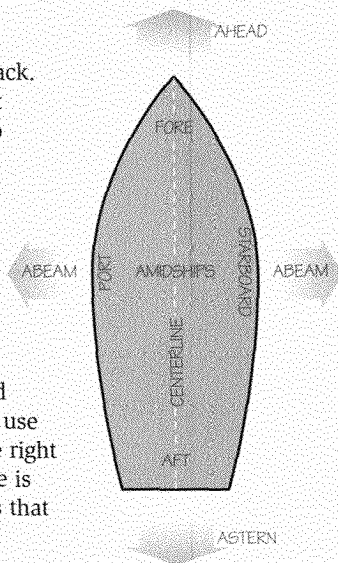

## Fins

Similar to the fins on a fish, sailboats need fins to help guide the boat through the water. Sailboat fins extend down into the water from the hull to provide for steering and stability. A sailboat needs two fins—a *rudder* and a *central fin*.



**Rudder**

### Rudder

The rudder is located at the stern, usually mounted on the transom of a small sailboat. It swings side to side, just like a door opening and closing. When the rudder is turned, it bends the flow of water moving past it and causes the stern to swing to one side. The bow rotates in the opposite direction.

Attached to the top of the rudder are a *tiller* and *tiller extension*—the stick that the helmsman uses to turn the rudder. Some small sailboat rudders kick up to prevent damage when the boat is beached or if it runs aground (hits bottom) in shallow water.

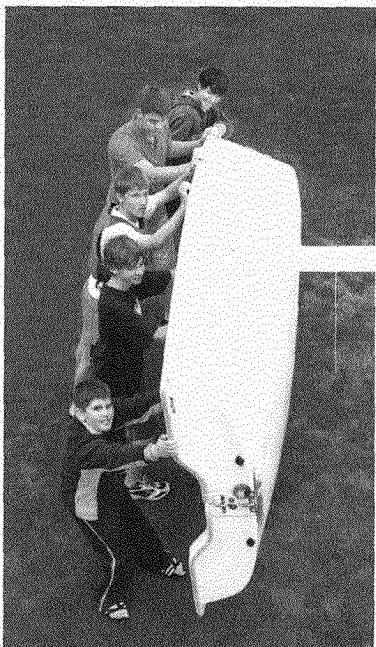

**Centerboard**

### Central Fin

Central fins have the same three functions on any sailboat, regardless of its size. A central fin prevents the hull from skidding sideways, or side-slipping; it provides a pivot point for turning; and it increases stability so the boat is less tippy. The three types of central fin—*centerboard*, *daggerboard*, and *keel*—all do the same thing, but they can be quite different in design.

A centerboard is a very common type of central fin on small sailboats. It is retractable and can be lowered into the water from the hull after the boat is launched. The centerboard resides inside the centerboard trunk, a narrow watertight housing in the center of the cockpit, when it is not in use.

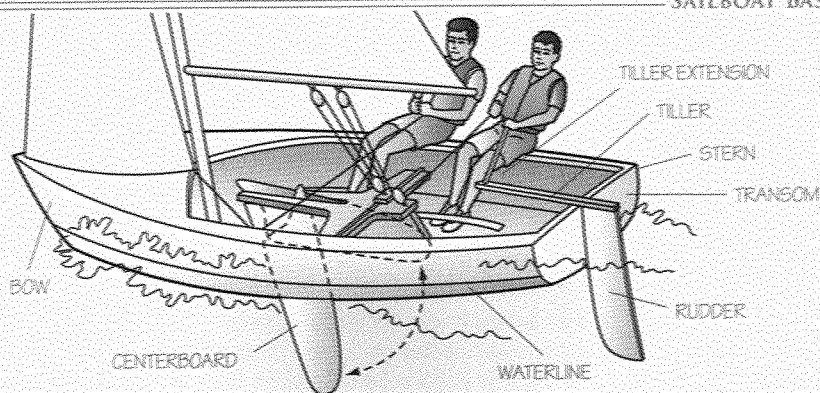

The centerboard is controlled by the centerboard pennant, a line used to raise and lower it into the water. The centerboard pivots fore and aft around a pivot pin located in the centerboard trunk. Because the centerboard retracts by swinging aft into its trunk, it protects itself from serious damage if the boat strays into shallow water and runs aground.

A daggerboard differs from a centerboard mainly in the way it retracts: A daggerboard plunges straight down when lowered and raises straight up and lifts out, rather than swinging like a centerboard.

Also, a daggerboard does not "live" inside the hull as a centerboard does. It is entirely removed and may be stored separately. A daggerboard slides up and down through a daggerboard trunk, a watertight slot in the hull.

Since a daggerboard cannot kick up automatically like a centerboard, it is important to raise it in time to avoid serious damage from running aground when in shallow water or when sailing to a beach.

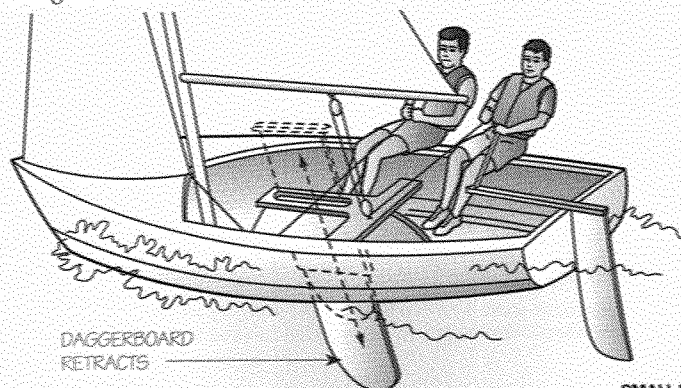

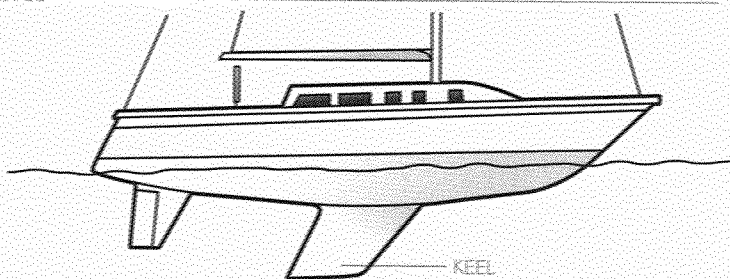

A keel is rarely seen on small sailboats because of its size and weight. A keel is not retractable; it is usually a fixed fin, built permanently into the hull. Keels on larger sailboats have *ballast*, or heavy weights, built into them to increase stability. Without a ballasted keel, most large sailboats would capsize the moment they were launched.

## Spars

To support and spread its sails, sailboats use special poles called spars. *Masts* are vertical spars that hold sails up. *Booms* are horizontal spars that spread sails out.

In the early days of sailing, spars were made of wood. Today, most spars are made of aluminum or a carbon-fiber composite material. They are stronger, lighter, and easier to maintain than wooden spars.

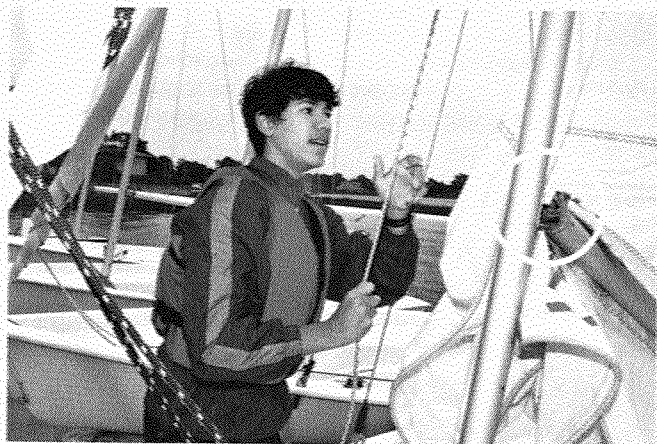

The boom is joined to the mast with a fitting called a gooseneck, which allows the boom to swing side to side and up and down.

## Rigging

There are two types of *rigging* on a sailboat. *Standing rigging* is made of stainless-steel wires that support and stabilize the mast. *Running rigging* includes all the ropes that hoist, shape, and *trim* (adjust) the sails.

### Standing Rigging

The main responsibility of standing rigging is to hold up the mast. It is not normally adjusted while a sailboat is under way, so it gets its name from "standing" still. Running rigging is routinely handled and adjusted while under way.

Standing rigging is made up of *stays* and *shrouds*, which often are made of the same wire. Their only difference is location. Stays extend fore and aft from the mast and are anchored to the hull along the boat's centerline. Shrouds extend from the sides of the mast and are anchored to the chain plates on the deck's port and starboard edges.

Stays provide fore and aft support to the mast. A forestay is led to the bow and prevents the mast from tipping over backward. Each item of standing rigging has a specific name, but anything that attaches to the centerline is called a stay.

Shrouds keep the mast from falling sideways. In a small sailboat, the shrouds are anchored to the outer edges of the deck slightly aft of the mast. This location also keeps the mast from tipping forward.

Adjusting the tension of the standing rigging, or *tuning*, usually is not done while under way. If a piece of standing rigging were accidentally released, the mast could suddenly fall, causing injury to the crew.

Some small sailboats, such as Optimists, Sunfish, and Lasers, have freestanding masts. The mast simply drops into the mast step built into the hull. The mast step provides enough support to keep the mast upright.

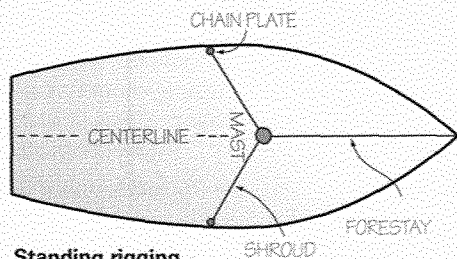

Standing rigging

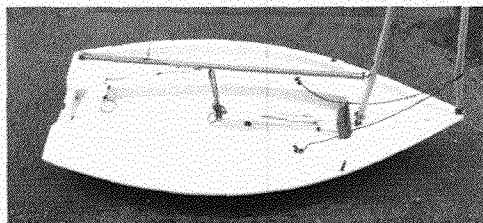

Standing rigging, side view

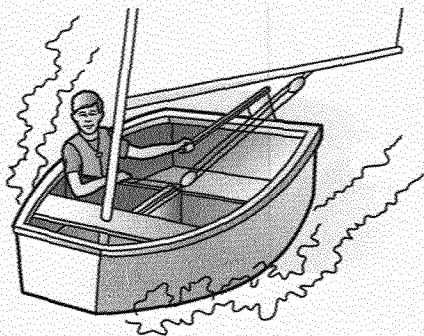

The freestanding mast of an Optimist pram needs no standing rigging.

## Running Rigging

Commonly made of low-stretch braided polyester, running rigging controls a sailboat's sails. Some sailors use different colors of line to code different items of running rigging.

Typical running rigging includes:

- Halyards—hoist sails up the mast
- Sheets—trim sails in against the pressure of the wind
- Outhaul—stretches the mainsail out along the boom
- Cunningham—stretches the mainsail downward after hoisting
- Boom vang—prevents the boom from riding up

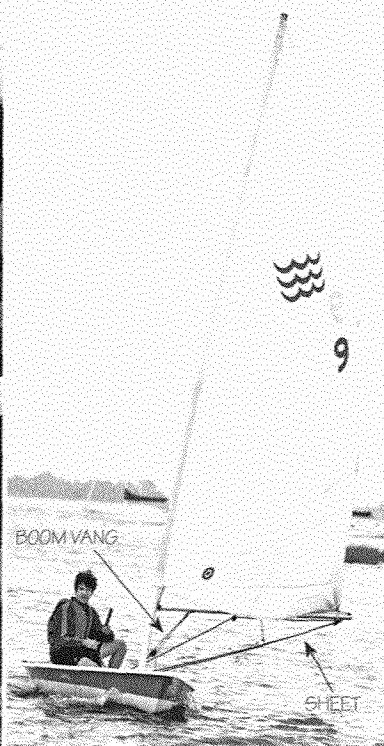
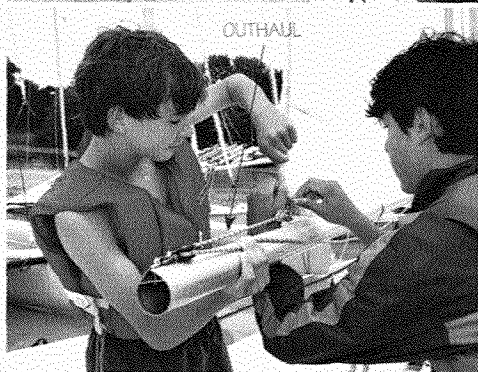



## Sails

Sails are the sailboat's engine. They gather energy from the wind and pass it along through the spars and standing rigging to the hull. Most modern sails are triangular.

The corners of any triangular sail are called the *head* (top), the *tack* (forward lower), and the *clew* (aft lower). The sides of any triangular sail are called the *luff* (leading edge), the *leech* (trailing edge), and the *foot* (bottom). *Battens* are flexible sticks that are inserted into pockets distributed along the leech. They keep the leech from curling and help to hold the sail's shape.

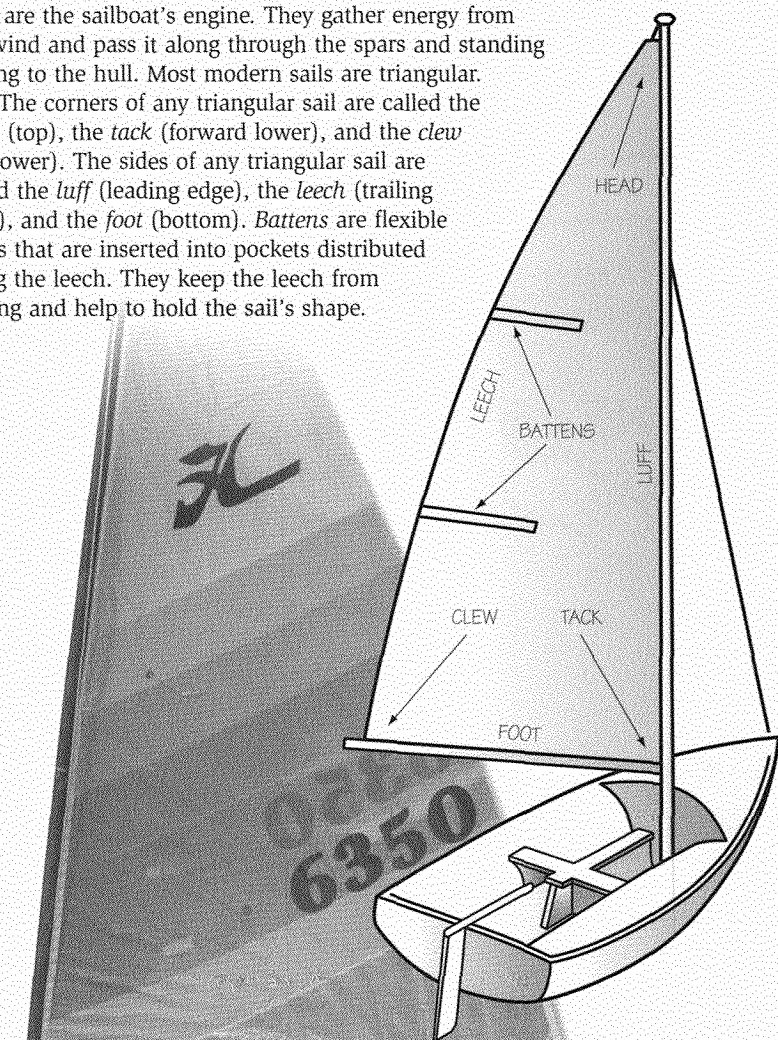

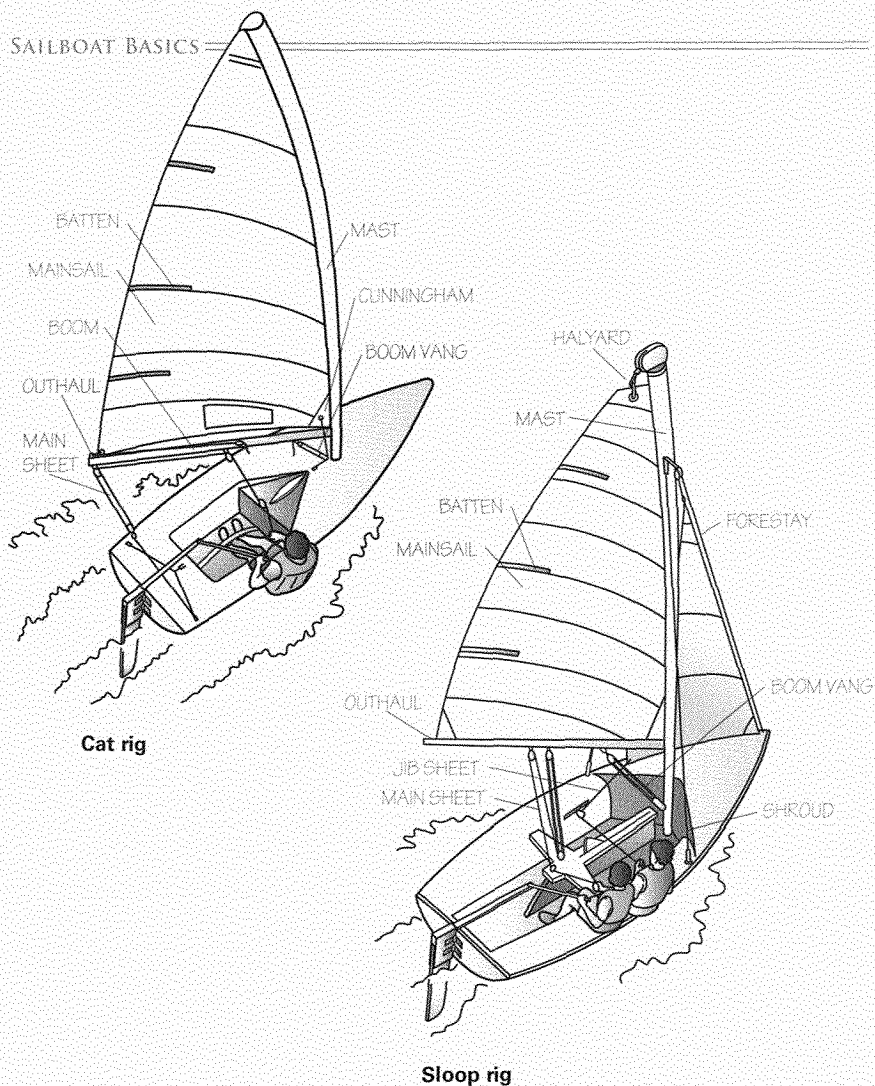

Cat rig

Sloop rig

The number and arrangement of sails and masts a boat carries is its *rig*. Many small sailboats have just one mast and one sail, a *cat rig*. Some have two sails, a *sloop rig*.

In a sloop, the larger sail spread open by the mast and boom is called the *mainsail*—sometimes simply called *the main*—and the smaller sail, attached to the forestay forward of the mast, is called the *jib*.

Designed for cruising longer distances, larger sailboats may have more than one mast and several sails.

- A *genoa jib* may be larger than the mainsail.
- A *gaff-rigged* boat has a diagonal spar called a gaff.
- A *ketch* has a mizzen mast aft of the taller main mast, just ahead of the rudder post.
- A *yawl* has a short mizzen mast aft of the rudder post.
- A *schooner* has one or two foremasts ahead of the main mast.

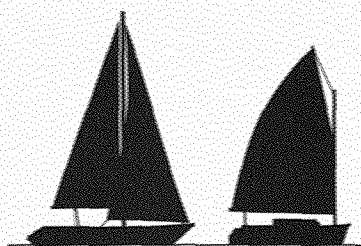

Sloop with  
genoa jib

Gaff-rig

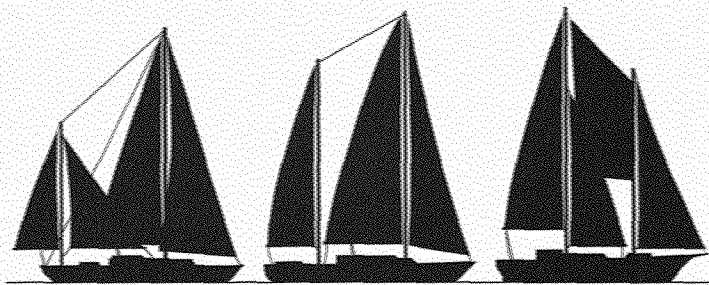

Yawl

Ketch

Schooner



# Wind

The two key things to know about wind are its direction and speed. Wind direction determines where a sailboat may go and how the crew trims the sails. Wind speed determines how much power a sail has to use.

## Direction

To sail well, you must be aware of the direction the wind approaches the hull at all times. It is not always easy to do, and wind occasionally may shift without much warning.

There are a number of ways to tell wind direction while sailing or getting ready to sail. The best and most reliable wind indicators are ripples, which form when the wind brushes the surface of the water. Ripples march in parallel patterns, pushed from behind by the slightest puff of wind. The direction from which the ripples come is the direction of the wind. Ripples react, turning direction almost instantly, to wind shifts. Observe only the smallest ripples that ride on top of any bigger waves or chop.

You also can observe the fluttering of flags on your boat, another boat, a flagpole, or even the *luffing* (flapping) of a sail. Some people attach telltales such as ribbons or pieces of yarn to their sailboat's shrouds or mount a masthead fly (a small weather vane) on the mast. Another simple but effective direction indicator is your own face—the wind is coming from the cool side.

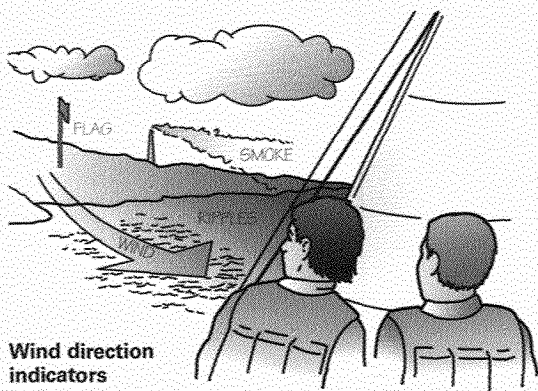

Wind direction indicators

---

A flag on shore shows "true" (actual) wind, whereas a flag onboard shows "apparent" wind. You will trim the sails based on the apparent wind direction, which is a combination of true wind and the boat movement.

---



## Velocity

Wind speed may suddenly increase (*gust*) or decrease (*lull*). As wind blows across the water, it leaves visible evidence of its velocity in the surface color and texture. Darker patches of ripples indicate stronger winds and gusts. Lighter colored ripples and smoother water surface (flat spots) indicate lighter winds. By carefully observing ripples approaching your boat, you can “see” the wind coming and predict puffs and wind shifts some distance away.

Sailors use the directional terms *windward* to describe where the wind is coming from and *leeward* (pronounced *loo'-werd*) to describe where the wind is headed. The windward side of a boat means the side from where the wind is coming.

The leeward side is the downwind side, away from the wind.

The words *windward* and *leeward* mean the same as “upwind” and “downwind.” When sailors use the words “up” and “down” to describe a direction (like “head up” or “head down”) they mean upwind or downwind. So if someone tells you to “head up,” it means steer upwind a bit. “Head down” means steer downwind.

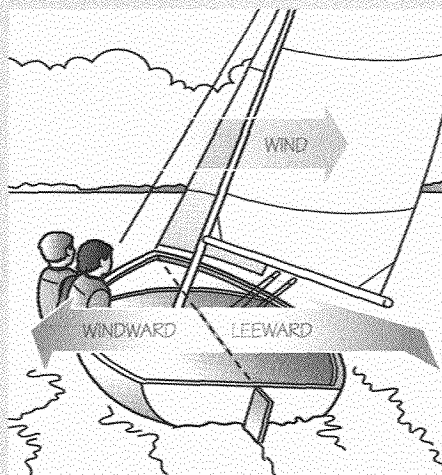

## Stopping a Sailboat

A sailboat cannot make sudden stops. Stopping a sailboat is like stopping a bicycle on level ground without using your brakes. On a bicycle, first you would stop pedaling. Then you would allow the bike to coast until it runs out of energy and slows to a halt. Because it is not easy to tell exactly where the bicycle will be when it finally stops, you have to plan ahead and leave plenty of room.



Stopping a sailboat takes planning, too. It needs plenty of room to use up its energy before it can stop. Sailboats gradually coast to a stop after the power is released from the sails and the hull has used up all of its *momentum* (the energy that keeps a sailboat moving even after its sails are no longer filled with wind).

To stop a sailboat, you must do two things:

1. Turn the boat with the bow headed into the wind.
2. Release all the sheets so that the sails luff freely and shed their wind power.

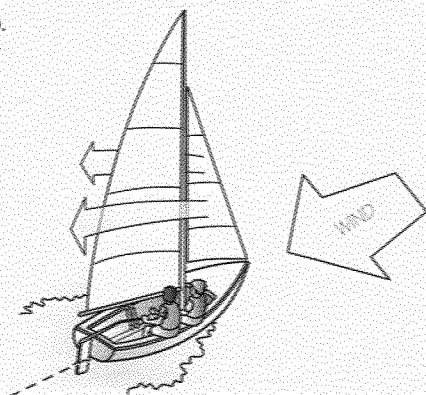

The sails will not luff fully unless the bow is turned into the wind (or pretty close to it).

## Mooring

To stop at a specific spot, such as a mooring buoy, a sailboat must begin its approach from some distance downwind. Judging exactly how much coasting distance the boat will need to end up stopped right at the buoy, the skipper then turns upwind. With its sheets released and the sails fully luffing, the boat begins to coast, gradually using up its momentum and slowing as it approaches the mooring buoy.

Estimating a sailboat's momentum can be troublesome. It is easy to misjudge, and there is a very narrow margin for error. If the turn upwind is too close and the boat does not have enough coasting distance to use up its momentum, the boat will not stop when it arrives at the mooring buoy. On the other hand, if the turn upwind is too far away, the boat will coast to a stop too soon. Some boats can coast farther than others. Wind speed, hull weight, current, and sea conditions are all factors that affect a sailboat's momentum.

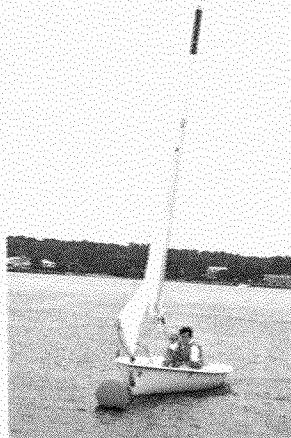

Mooring a sailboat

The only time a sailboat can move in reverse is when it is in irons.

Your judgment about how far a sailboat will coast will improve with practice. Rehearse stopping at a precise location by making repeated practice stops at a mooring buoy. You will learn from each attempt and gradually improve your stopping skills.

### Getting Out of Irons

If a sailboat turns into the wind and stops, it is *in irons*. Having pointed into the wind and stalled, the sailboat can no longer move ahead or be steered with the rudder. It is as though it were a prisoner chained up in leg irons.

To get out of irons in a cat-rigged sailboat, first put the boat in reverse for a few seconds. Push the tiller hard over in the direction you want the hull to go after you are out of irons. At the same time push and hold the boom out to the same side, enough to get the wind to fill the sail and push the hull backward. Hold it there until the boat backs up enough to turn sideways to the wind, then center the tiller and trim in the sail normally. As the boat gains forward speed, it will begin to steer properly.

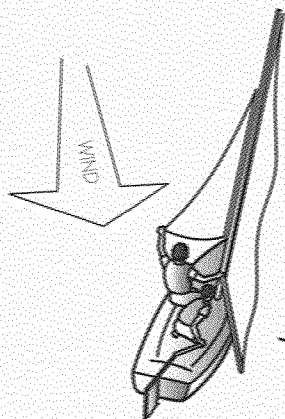

To get out of irons in a sloop-rigged boat, hold the tiller in the center and back the jib by grasping the clew and holding it well out to one side of the boat. When the wind fills the backed jib, it presses against it and turns the bow away from the wind. Once the bow turns enough, the boat is out of irons and may resume sailing normally.

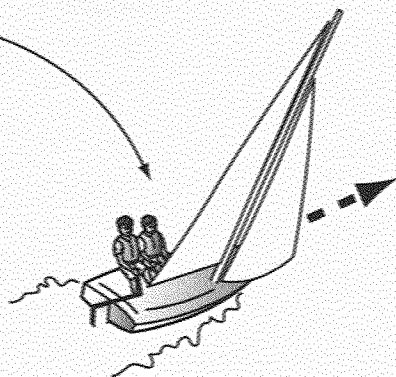

## Docking

Docking often can be easier than sailing to a mooring buoy, because it may allow more room for error. Because a sailboat pulls up and stops alongside a dock, it does not necessarily need to stop at a specific spot. It may have the entire length of the dock to use up its momentum and come to a stop.

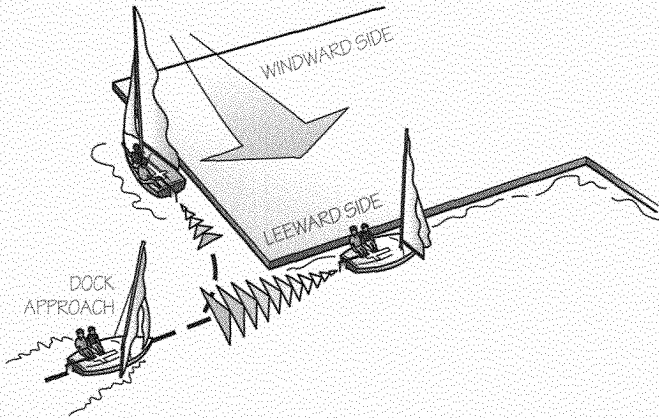

When stopping at a dock, choose a side that is lined up with the wind as much as possible. Begin your approach from the downwind end. That way when you turn up alongside you can meet the two essential rules of stopping: (1) Turn into the wind (or pretty close), and (2) release all sheets so the sails can fully luff. By coming up alongside the dock, you have the option of safely circling around and approaching again with less speed on a second try.

## Beaching

Beaching can be tricky. As your boat approaches a beach and the water gradually gets shallower, you must raise the fins to prevent damage from their dragging against the bottom. But because raising the fins affects your ability to steer the boat, you must make your turn into the wind (to stop) just before the water gets too shallow to keep your fins from hitting bottom.

---

Never sail into a dock with your bow pointed squarely at it.

It would be like driving a car with no brakes into a garage. If you have too much momentum and are unable to stop in time, you will crash. If your sails are not fully luffing, do not attempt any approach to a dock.

---



# Getting Under Way

Going sailing requires a lot of preparation. You need to make sure you have the right equipment before you get under way. You also need to make sure you cast off safely, with all your equipment in place.

## Preparation Checklist

To make sure you do not forget something important, write down everything you need to have on board and everything you need to do before casting off. Keep this checklist in a safe place where you can find it easily. You can use the same list every time you go out. From time to time you may think of some other things to add to your list.

A preparation checklist might include:

- Legally required paperwork (such as a state-issued certificate of number or an operator's safety certificate)
- Life jackets—check their condition, and put them on
- Bailing equipment (pump, bucket, bailer scoop, sponge)
- Paddle or oar
- Drain plugs
- Whistle for emergency signaling
- Horn for fog and other signaling
- First-aid kit
- Rigging knife
- Tool kit
- Anchor and line

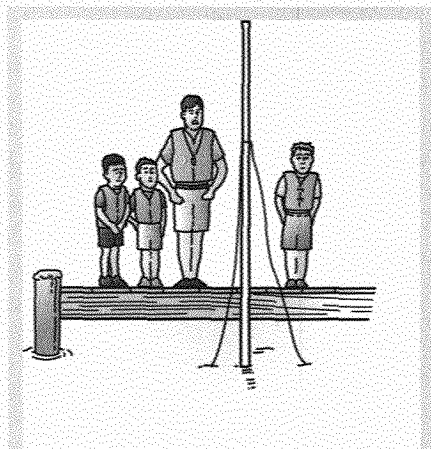

*Next time let's put drain plugs on the checklist.*

- Spare line/tow line
- Chart and compass
- Handheld two-way radio  
(Do a radio check.)
- Flashlight (Check the batteries.)
- Food and beverages
- Foul-weather gear
- Fuel (if you have an auxiliary engine)
- Float plan (File your float plan with someone onshore.)

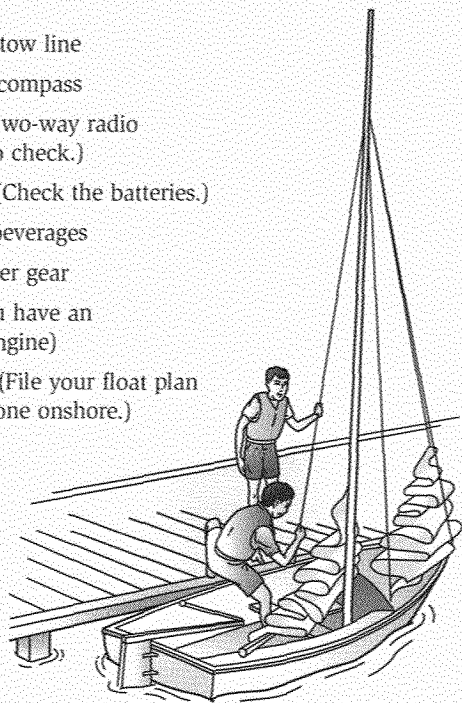

## Boarding

Small sailboats are often quite tippy until their fins are lowered. To avoid an embarrassing capsize before you even raise your sails, follow the correct procedure for boarding a small boat.

**Step 1**—Pull the boat alongside the dock.

**Step 2**—Get a crewmate to hold the boat steady alongside the dock while you board.

**Step 3**—Do not try to board over the bow. Instead, crouch down at the edge of the dock as close to the middle of the hull as possible. Hold onto the deck and shroud to steady yourself as you step sideways (toes toward the bow) directly onto the cockpit floor. Do not step on the deck or a seat. As you transfer your weight from the dock into the boat, keep a three-point stance so you do not lose your balance. Of your two hands and two feet, three of the four should always be in contact with the boat or the dock.



**Step 4**—Once completely in the boat, sit or crouch down immediately to lower your center of gravity. Never stand up.

**Step 5**—If the water is deep enough, lower the centerboard immediately after boarding, before loading any gear or other passengers.

**Step 6**—Bring gear in from the dock and stow it.

**Step 7**—Hold the boat steady alongside the dock while other passengers board, also using the three-point stance.

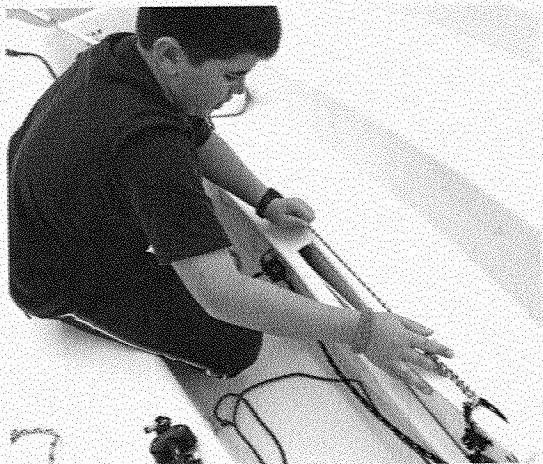

Lowering the centerboard

## Rigging

Rigging is the process of *bending on* (attaching) and hoisting the sails. Every boat is rigged a little differently, so you will need some time to become familiar with the setup of each new boat you sail.

You can bend on the sails as soon as the fins are lowered and all the gear is stowed. Detachable rudders are most easily installed before the sails are raised (especially if the boat is moored). Slide the *pinles* (metal rods secured to the rudder) into the *gudgeons* (rudder supports) to form a hinge for the rudder to rotate on.

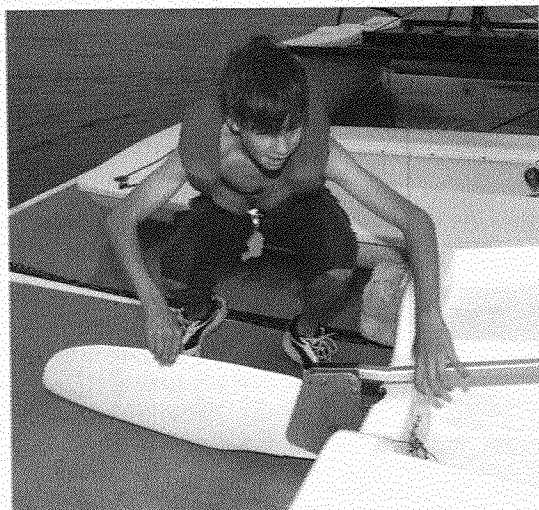

Attaching the rudder

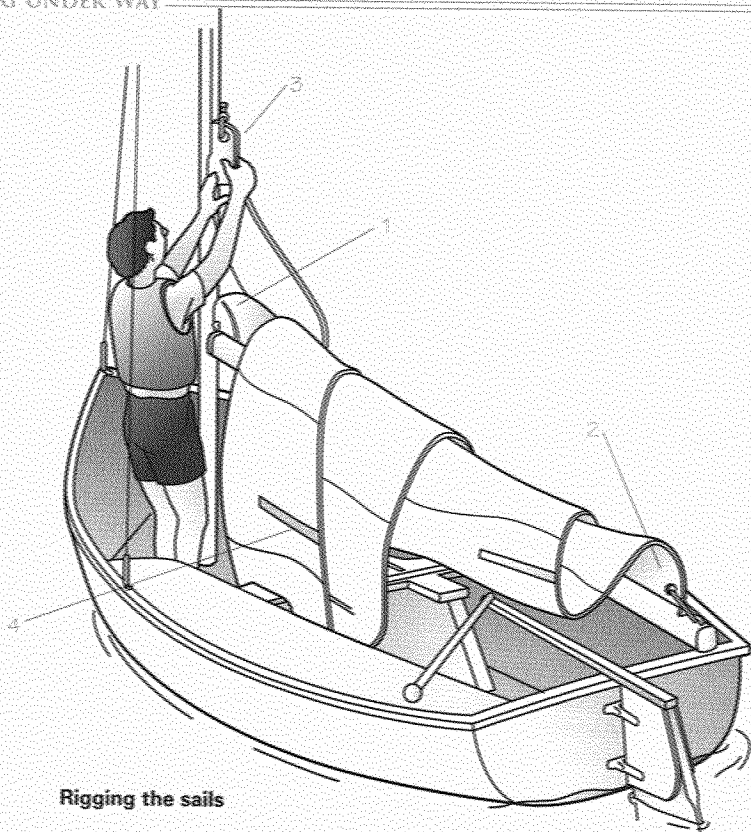

**Rigging the sails**

Attach the three corners of the sails in order by tack (1), clew (2), and head (3). Depending on the design, the mainsail's luff bolt rope may need to be fed into the mast's groove. Insert and secure any battens (4).

*Reave* (thread) the sheets through their blocks or fairleads and tie figure-eight knots in the ends (see "Marlinespike Seamanship").

Before hoisting sails, be sure the hull is pointed into the wind. Do not try to raise sails with the wind approaching from astern. The sails should luff freely as they are raised. The main usually is raised first so it can help hold the boat into the wind until the jib can be raised. Coil and secure the halyards, and you are ready to go.

## Shoving Off

When you are ready to shove off, or leave the dock, take a good look around for any approaching vessels or nearby obstructions. Be sure the coast is clear. Take the tiller and, when it is safe to do so, have a crewmate or dockhand push the bow gently away from the dock and wind.

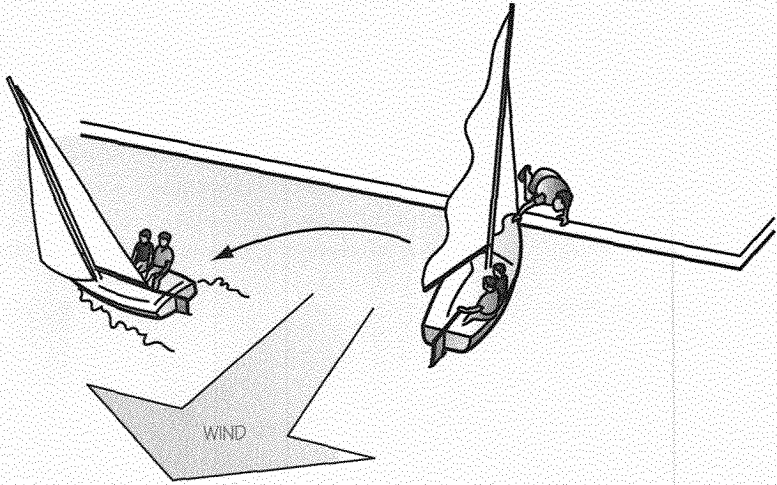

## Cockpit Seating

If you are the skipper, you should sit on the windward side of the cockpit. Steer with your aft hand. Keep your shoulders square to the boom and your head facing forward. Sit far enough forward in the cockpit that you do not crowd the tiller; it should be able to swing freely from side to side at all times.

The crew should sit on whichever side of the boat is required to keep the hull level. A little *heel* (tilt) is perfectly normal, but as the wind increases in strength, heel may become excessive. The crew should be prepared at all times to move across the cockpit and *hike out* (sit on the edge of the deck and lean out to windward) with changes in wind velocity.



## Steering

The steering mechanism of a boat is called the *helm*. In a small sailboat, the helm includes the rudder and the tiller.

An odd thing about steering with a tiller is that you have to push it one way in order to go the other way. It takes some practice to break yourself of the instinct to aim the tiller where you want the boat to go. A sailboat steers right or left when the rudder is turned in that direction. The rudder moves in the opposite direction of the tiller—and so does the boat.

---

To steer right,  
move the tiller to  
the left; to steer  
left, move the  
tiller to the right.

---



Port turn

To turn to starboard, move the tiller to port. To turn to port, move the tiller to starboard.

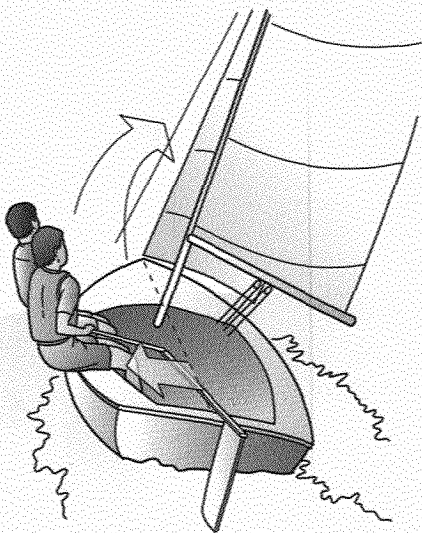

Starboard turn





# Sailing Fundamentals

## Points of Sail

The *points of sail* are names sailors use to describe the direction the wind approaches the hull of a sailboat. There are five points of sail: *beating*, *close reach*, *beam reach*, *broad reach*, and *running*.

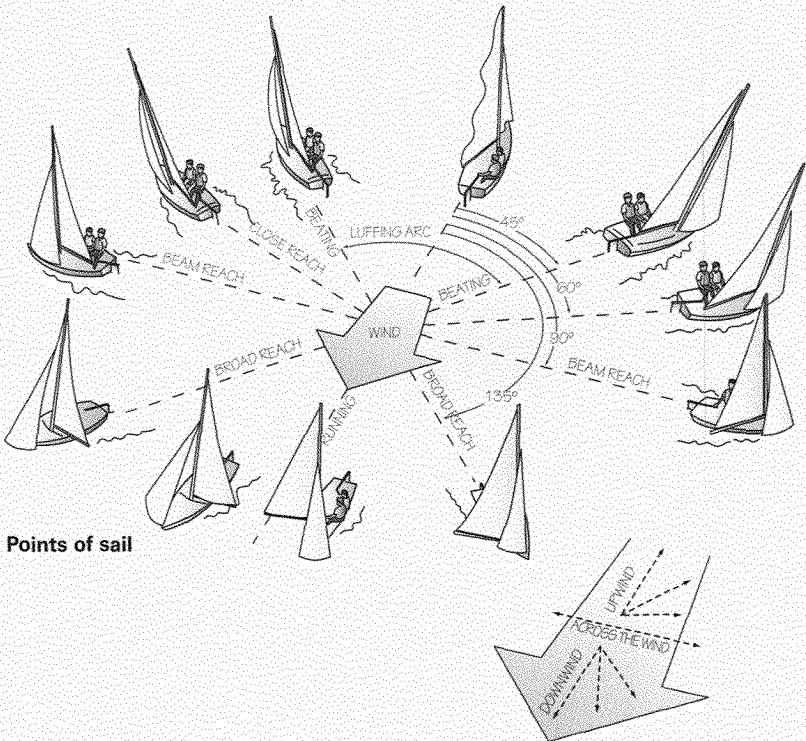

Points of sail

The luffing arc is sometimes called the no-go zone. If a sailboat enters the luffing arc, the boat will slow down and go into irons.

It is impossible for any sailboat to sail directly into the wind. Attempting to do so will cause a sailboat to stop and go into irons. The closest most sailboats can *point* (the course steered while beating) toward the wind is roughly 45 degrees on either side. That creates the *luffing arc*, a wedge of about 90 degrees (a quarter of a circle) in which a sailboat cannot go.

A sailboat is *running*, or *on a run*, when it is headed exactly where the wind is going. The wind pushes the boat squarely from behind, favoring neither side. When running, a sailboat goes fastest when the sails are spread all the way out to the side of the boat, where they can capture the most wind. It does not matter on which side the boom is carried, as long as it is fully extended to present the maximum sail area to the approaching wind.



It is understandable to think that running might be the fastest point of sail, since the wind pushes the boat from directly behind, but actually running is the slowest. When a sailboat is running, the wind presses against the sail and then spills around the edges, similar to water flowing around a rock in a stream. The wind becomes

turbulent, swirled and unsteady, a condition called stalling. Stalling is not as powerful a force as lift, which propels a sailboat on all other points of sail. Lift occurs when the wind slides smoothly along both sides of a sail from luff to leech. (See "Sail Trim" later in this chapter.)

*Reaching* is cross-wind sailing, that is, when the wind approaches the boat from the side, rather than from ahead or behind. There are three reaches: *close reach*, *beam reach*, and *broad reach*. The differences among them have to do with whether the wind approaches the hull squarely from one side or a bit fore or aft.

A sailboat is on a beam reach only when the wind comes squarely from one side of the boat. A beam reach is the fastest point of sail for most sailboats. Sails are trimmed roughly halfway in for a beam reach.

A sailboat is on a broad reach when the wind comes roughly from the aft corner (quarter) of the hull. When broad reaching, the sails are trimmed more than halfway out.

A sailboat is beating when it is sailing on the edge of the luffing arc, pointing as close to the wind as possible without stalling and going into irons.

A sailboat is on a close reach when it is heading anywhere between beating and beam reaching. It gets its name from steering "closer" to the wind (more upwind) than a beam reach. A sailboat on a close reach ordinarily should have its sails trimmed roughly three-quarters of the way in.



## Starboard Versus Port Tack

In addition to being on one point of sail or another, a sailboat under way also is either on a *port tack* or *starboard tack*. A sailboat is on the tack corresponding to the side opposite its mainsail boom.

Sometimes the easiest way to tell which tack a sailboat is on is to see which side is the windward side. If the wind comes from the starboard (right) side of the boat, the starboard side is the windward side. Thus, it is on starboard tack. If the wind comes from the port (left) side of the boat, the port side is the windward side, so it is on port tack.

Sailors often use a form of shorthand when communicating. For example, a skipper might say, "After leaving the harbor, we will begin beating on starboard tack." The words "beating on starboard tack" tell the crew which side will be the windward side, which side the sails will be on, where they should be positioned in the cockpit, which jib sheet to trim, and roughly how much to trim it in.



The boat on the *left* is on starboard tack. The boat on the *right* is on port tack.

When a sailboat is on a run, the wind comes from directly astern, favoring neither side, but the boat is still on a tack. You can tell which tack it is on, because it is the side opposite the mainsail boom, just like all other points of sail. So, when the boom is carried on the port side, the boat is on starboard tack. When the boom is carried on the starboard side, it is on port tack.

## Safety Position

A convenient way for a sailboat to stop temporarily without going into irons is to use the safety position. The safety position can be used for stopping to chat with a passing boater, pausing to get your bearings, waiting for a boat to catch up, or taking time out to handle an emergency on board.

To go into the safety position, put your boat on a close reach and release the sheets so the sails luff fully. The boat will coast to a stop and drift slowly.

You can get out of the safety position and resume sailing simply by trimming in your sails.

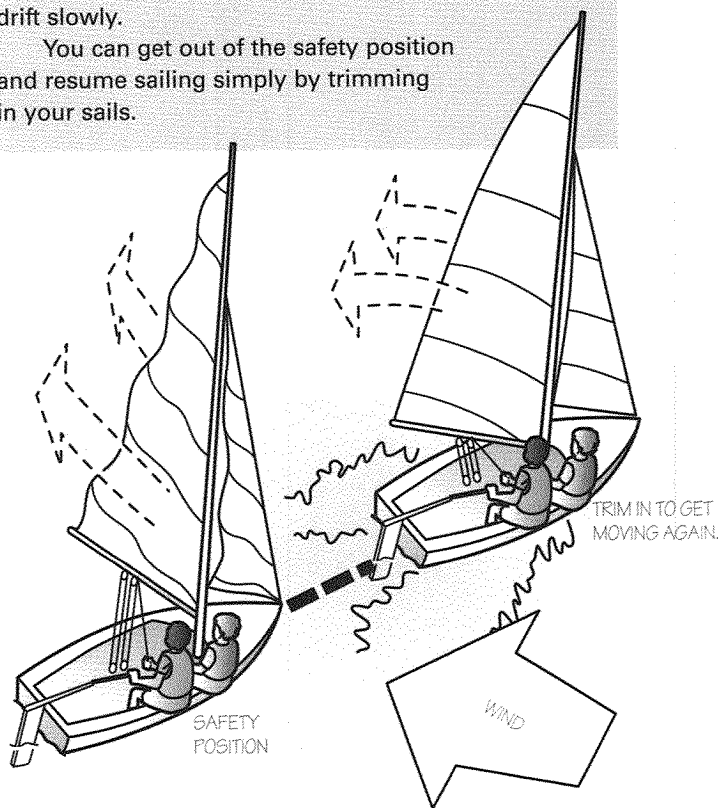

## Tacking and Jibing

There are only two ways a sailboat can switch from one tack to the other. It may turn upwind and *tack*, or it may turn downwind and *jibe* (sometimes spelled *gybe*).

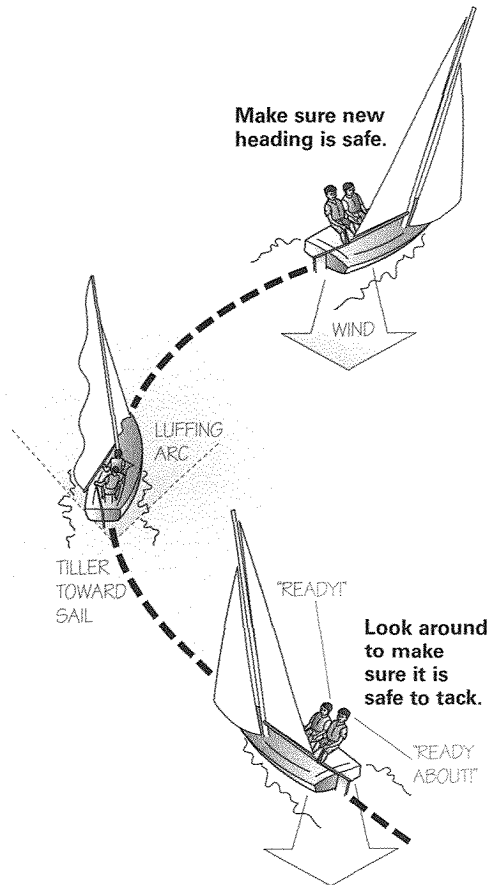

*Tacking and coming about* mean the same thing. The two terms are used equally, so do not be surprised to hear someone switch back and forth between them. A sailboat tacks (comes about) when it turns upwind and beyond until the sails fill on the opposite side. Tacking usually requires a turn of at least



90 degrees (a quarter turn), because that most often is the span of the luffing arc. Whenever a sailboat makes a turn completely through the luffing arc, the wind fills the sails on the opposite side. When that happens, the boat has changed tacks by coming about.

Since tacking is perhaps the most common maneuver in sailing, it is important to learn it well. On a sloop-rigged boat, the duties usually are divided among the skipper and the crew. Both skipper and crew have important duties to perform and they should be coordinated.

The skipper's duties include

- Giving the commands ("ready about" followed by "hard alee")
- Steering the boat through the turn
- Switching seats

When you are the skipper, you make the decisions about where the boat goes, including when to tack. Because tacking requires teamwork on a multihanded (having one or more crewmates) sailboat, you must communicate your intentions, so everyone can prepare and cooperate.

Just before coming about, alert the crew by announcing, "Ready about." The command should be loud enough for everyone to hear. Pause a few seconds to let the crew prepare and acknowledge hearing your command, usually by responding "Ready." Then say "Hard alee" as you push the tiller to the leeward side. This tells the crew that you are in the act of turning.

As skipper, it is important for you to face forward during a tack and watch the horizon. Watching the horizon helps keep you oriented, so you know how far to turn and when to stop. If you glance away from the horizon, you may lose your bearings and oversteer. Just as you complete the tack, pull the tiller back to the centerline of the hull to resume a straight course.

During the tack, just before the sails begin to fill on the other side, it is time to change seats. Move directly across the cockpit to the other side of the boat. Since you will be facing forward, you will need to pass the tiller from one hand to the other behind your back. This behind-the-back tiller handoff takes some practice, but it becomes second nature after a while.

The crew's duties include releasing the active jib sheet, switching seats, and trimming in the other jib sheet. The primary responsibility of the crew in a sloop-rigged boat is to

tend the jib. During a tack, the jib sheet must be released on one side and trimmed in on the other side of the boat. It is a routine procedure, but timing is important.

The first step in tacking is to release the jib sheet. Be careful not to release it too soon. The jib sheet should not be released before the jib starts to luff on its own (as the boat enters the luffing arc). Releasing the jib too early allows it to luff and spill away needed power going into the turn. This sudden loss of power can cause the boat to stall and go into irons. Remember, it is not the skipper's words "hard alee" that trigger the action of the crew to release the jib. It is the actual luffing of the jib as the boat enters the luffing arc. The crew should watch the jib closely during a tack and release the jib sheet only when the jib is fully luffing.

Once the jib is released, the crew should check to be sure the sheet does not catch on the fairlead (sometimes called the jib lead). The sheet must be free to allow the jib to carry over to the other side of the boat. The inactive jib sheet should dangle freely with no tension on it at all, so it does not affect the curve in the sail even slightly.

The second step in tacking is to change seats, moving across the cockpit to where the "new" jib sheet comes from the fairlead. The timing of this move depends on the speed of the turn. When the wind is gentle and the boat turns slowly, you will have plenty of time to get to the new windward side before the sails fill. When the wind is stronger, you will have to move more quickly to match the speed of the turn.

The third step in tacking is to trim in the new active jib sheet. Again, timing is important. Do not begin to sheet in the jib until it luffs its way across to the new leeward side of the boat. Sheeting in too soon could back the jib, stop the tack, and put the boat in irons.

## Jibing Procedure

Because the boom can swing suddenly and forcefully over the cockpit in a jibe, the maneuver can be dangerous. Unprepared crew members can be injured or knocked overboard by the boom. It is important to pay close attention to shifting winds (to avoid accidental jibes) and to adhere strictly to correct jibing procedure.

Jibing is another method of changing tacks. It is a maneuver used mainly when headed toward a downwind destination. It does not necessarily require a sharp turn (as in coming about), however. A sailboat on a run can jibe without changing course at all. A sailboat jibes when, with the wind at its stern, the boom swings from one side of the boat to the other and wind fills the sail on the opposite side.

There are two types of jibes: flying jibes and controlled jibes. A flying jibe can be particularly dangerous in high winds. A flying jibe (sometimes called a slam jibe) occurs when either a change of heading or a sudden wind shift causes the wind to approach the mainsail leech from the opposite side and throw the boom across to the other side of the boat. Because of the risk to crew safety and the potential damage to the boat from the boom's impact, flying jibes are generally avoided except in racing.

Controlled jibes are safer.

They allow the skipper to control the movement of the boom and reduce the risk of injury and damage. In a controlled jibe, the skipper trims in the mainsail just before the jibe, restricting how far it can swing. Then the skipper pays out the mainsheet after the jibe, controlling the rate it moves to leeward.

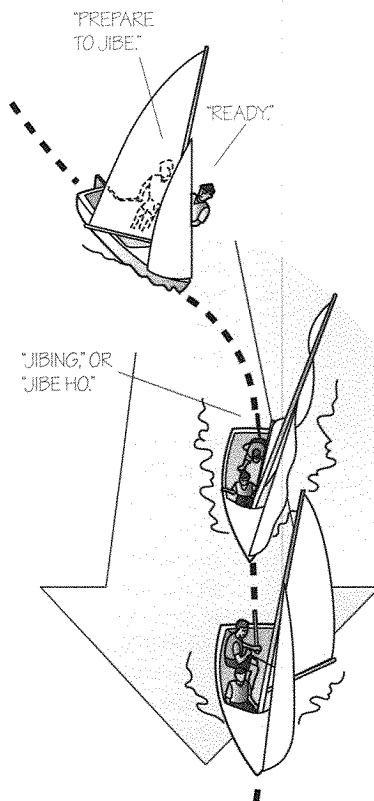

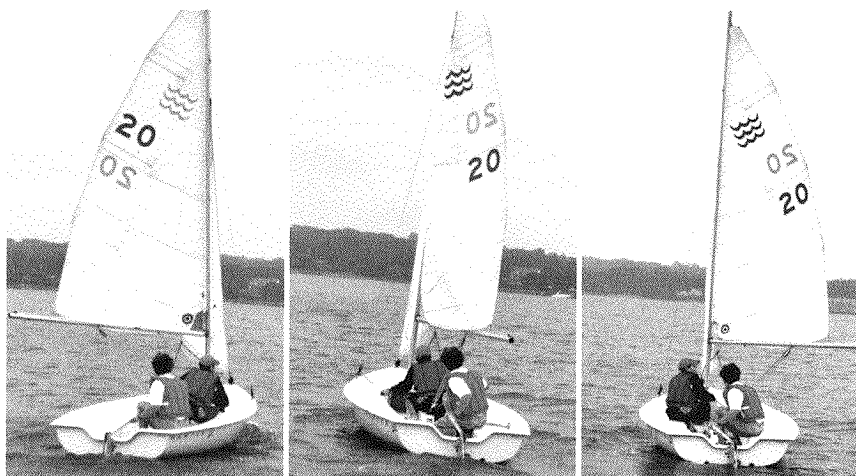

As with tacking, both skipper and crew have specific duties to perform during jibing. The skipper's duties include giving the commands, trimming the mainsail, steering the boat, changing seats, and retrimming the mainsail. As skipper you should alert the crew of an upcoming jibe by giving the command, "Prepare to jibe." Say it loudly enough for everyone to hear. Be certain that everyone understands the importance of keeping low until the boom has crossed overhead. Give the second command, "jibe ho," just before the boom actually begins to swing.

In a controlled jibe there are some steps in between the two commands. The mainsail must be sheeted in enough so that the boom cannot swing too forcefully. Leave enough time to trim prior to the actual jibe, perhaps five to 10 seconds.

Steer the boat through any turn you may need to make to head for your next destination. As with tacking, you should face forward, pass the tiller behind your back, and keep an eye on the horizon to stay oriented. Be careful not to oversteer, that is, turn beyond your intended heading. Say "Jibe ho" loudly, just before the jibe and in plenty of time for everyone on board to duck under the swinging boom. Change seats just as you would if you were coming about. Be sure to be in your new windward seat before the boom arrives on the new leeward side. Reset the mainsail position for your new heading.

The crew's duties in a jibe are very similar to those in coming about. The crew tends the jib, but the timing of the switch from one sheet to the other is a bit different. The crew's duties include releasing the active jib sheet, changing seats, and trimming the new active jib sheet. When the crew hears "Prepare to jibe," they should acknowledge hearing the command by responding "Ready." It is not yet time to act; it is simply time to become alert.

As a crew member, you release the active jib sheet, removing it from its cleat and allowing it to go free. You release the active jib sheet when the jibe is in progress—just as the boom starts to swing across the boat—immediately after the skipper calls out, "Jibe ho."

Then you change seats, or move from one side of the boat to the other. This should take no longer to do than the time it takes for the boom to swing from one side to the other. In breezy conditions it may be only a second or two.

Next, trim in the new active jib sheet. Do this immediately after changing seats. Since the leeward jib sheet you must now trim is on the side of the boat you just left, it helps to bring the line with you as you cross the cockpit.

**Never allow anyone to stand in the boat or to change seats until all on board are alerted.**

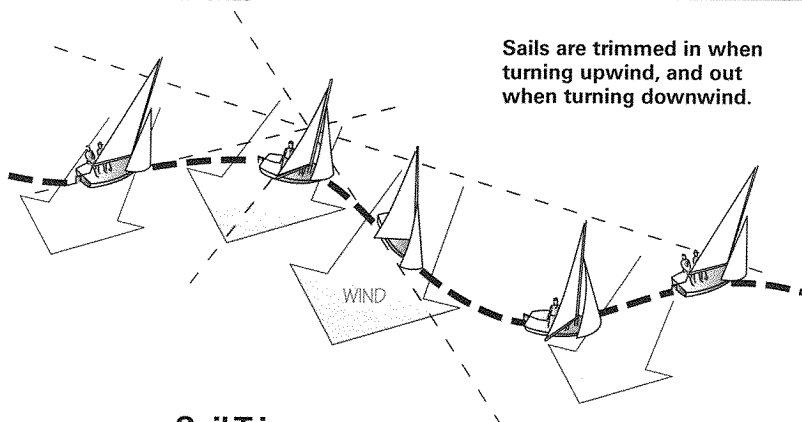

## Sail Trim

The term *sail trim* refers to the amount a sail is pulled in toward the centerline of the hull. Sails are trimmed by their sheets, so sometimes sailors use the expressions "trimming in" or "sheeting in" their sails. There are three fundamental rules of sail trim.

1. When sailing downwind (running), sails should be all the way out (square to the wind) to expose as much sail area to the approaching wind as possible.
2. When sailing on a reach (close reach, beam reach, or broad reach), the sails should be trimmed out as far as possible, but only to the verge of a luff. That means that if you sheet out the sail any more it will tremble slightly along its leading edge.
3. When sailing upwind (beating), sails should be trimmed all the way in.

The three rules of sail trim apply to all sailboats, and they apply to mainsails and jibs alike. Upwind (beating) and downwind (running) sail trim is easy, because you simply sheet the sail all the way in or all the way out. Reaching sail trim, however, requires some special attention.

The leading edge of any sail is called the luff, because it is where luffing begins when a sail is sheeted out too far. For instance, if you were to assume the safety position with the sails all the way out and the hull on a close reach heading, the sails would be luffing fully from luff to leech. As you start to



trim the sail in, it would fill first at its leech. Then, as you trim the sail in further, more of the sail would fill, with the remaining luff working its way out toward the leading edge. The last hint of a luff, a slight back pressure on the sail cloth at its leading edge, would eventually disappear. At that point the sail is perfectly trimmed—right at the verge of a luff.

It is important for the skipper to sail a straight course so the sails can be trimmed properly. Every time the boat changes its heading, it changes the angle at which the wind approaches the sails so the sails must be retrimmed. Any time the boat turns upwind, the sails need to be trimmed in to keep them from luffing. Any time the boat turns downwind, the sails should be sheeted out.

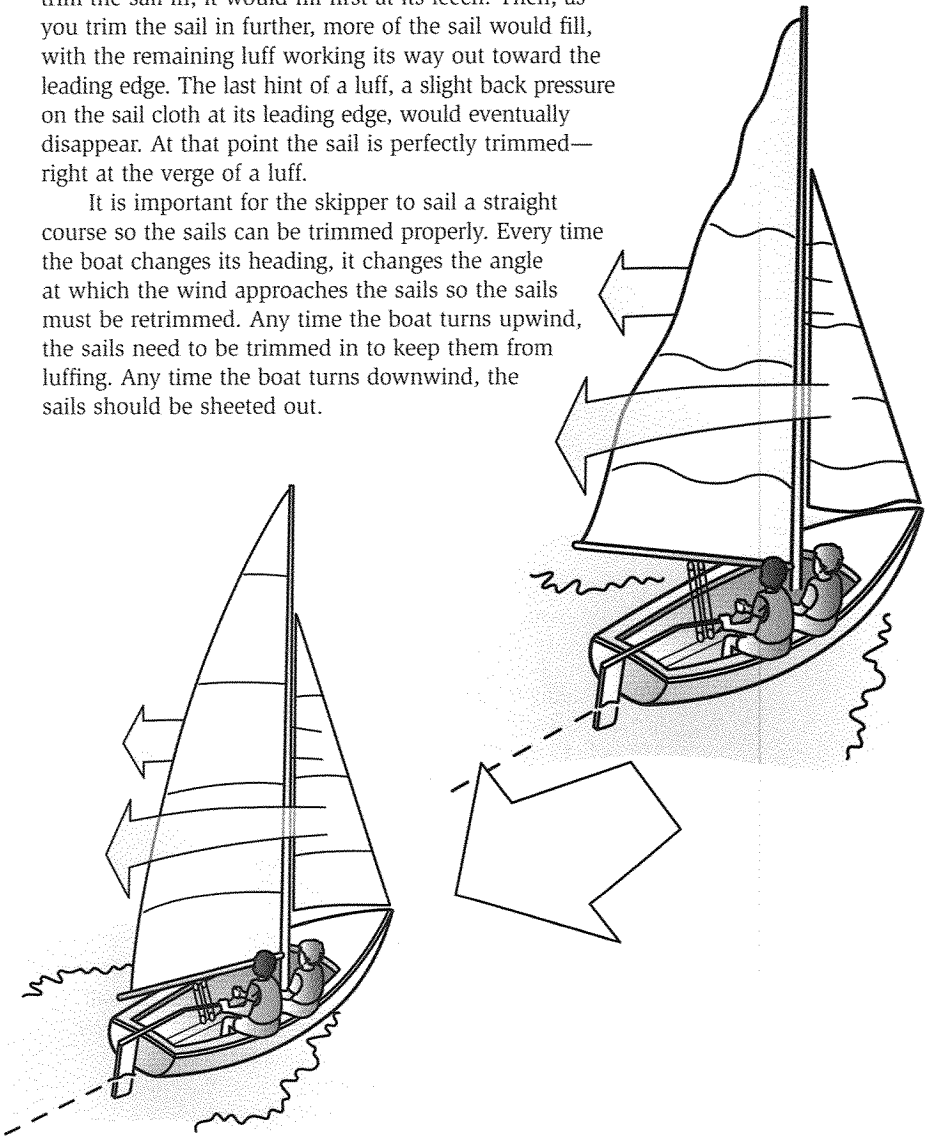

## Upwind Sailing

Because sailboats cannot sail directly into the wind, they must take an indirect route to an upwind destination. They must zigzag, alternately beating on port and starboard tack.

The closest most sailboats can head toward the wind is about 45 degrees—one-eighth of a circle. Recall that when a sailboat is sailing as close to the wind as possible, on the edge of the luffing arc, it is beating.

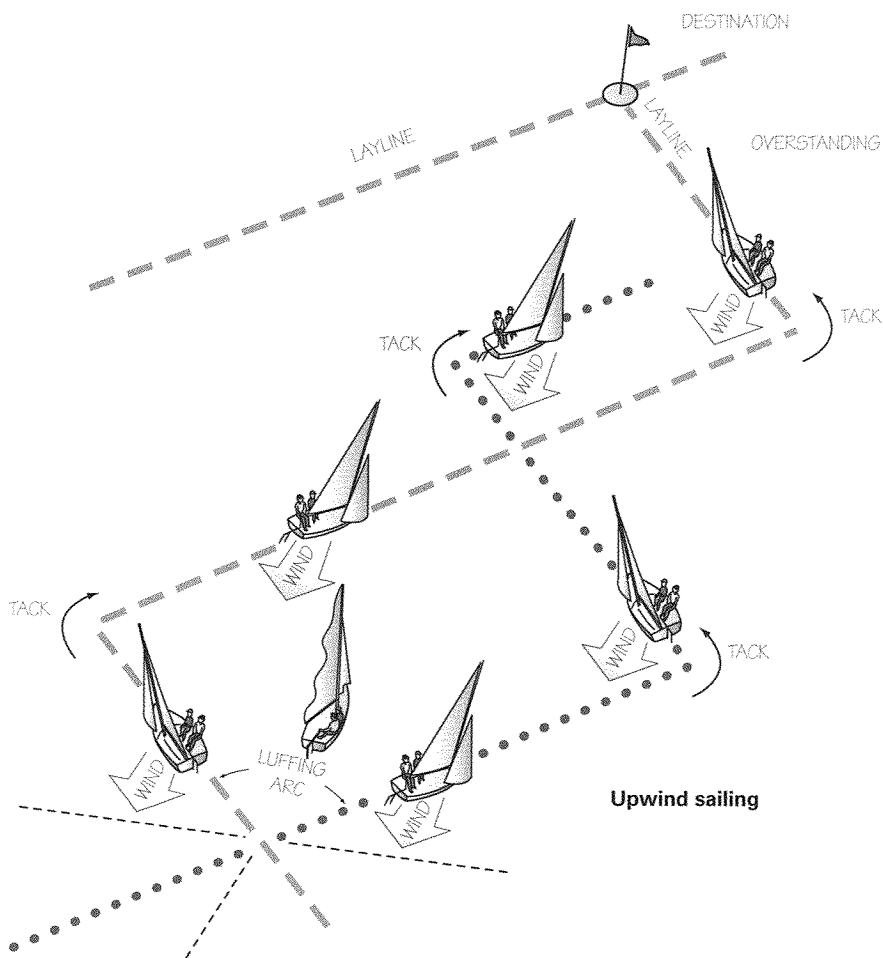

A sailboat beats upwind until it reaches a *layline* to its destination. When a sailboat reaches the layline (see diagram), it can *fetch* its destination (sail directly to it without having to tack again). There are two laylines for any upwind point, the starboard and port tack approaches.

Upwind helmsmanship requires concentration. While beating, you are sailing the invisible line on the edge of the luffing arc, between luffing and not luffing. Although you cannot actually see the line, you can tell where it is by testing the edge. Steer gradually upwind to see the point where your sail starts to luff. If your boat has a jib, watch the leading edge very carefully. Whenever you trespass into the luffing arc, your sails will warn you by luffing.

With practice and experience, you soon will develop a feel for the best course to steer to get upwind the fastest. Experienced helmsmen call this course "the groove." If you point too high, your boat will slow down. If you bear off too much, your boat will gain speed, but it will not make very good progress upwind. Staying in the groove will get you to an upwind destination the fastest.

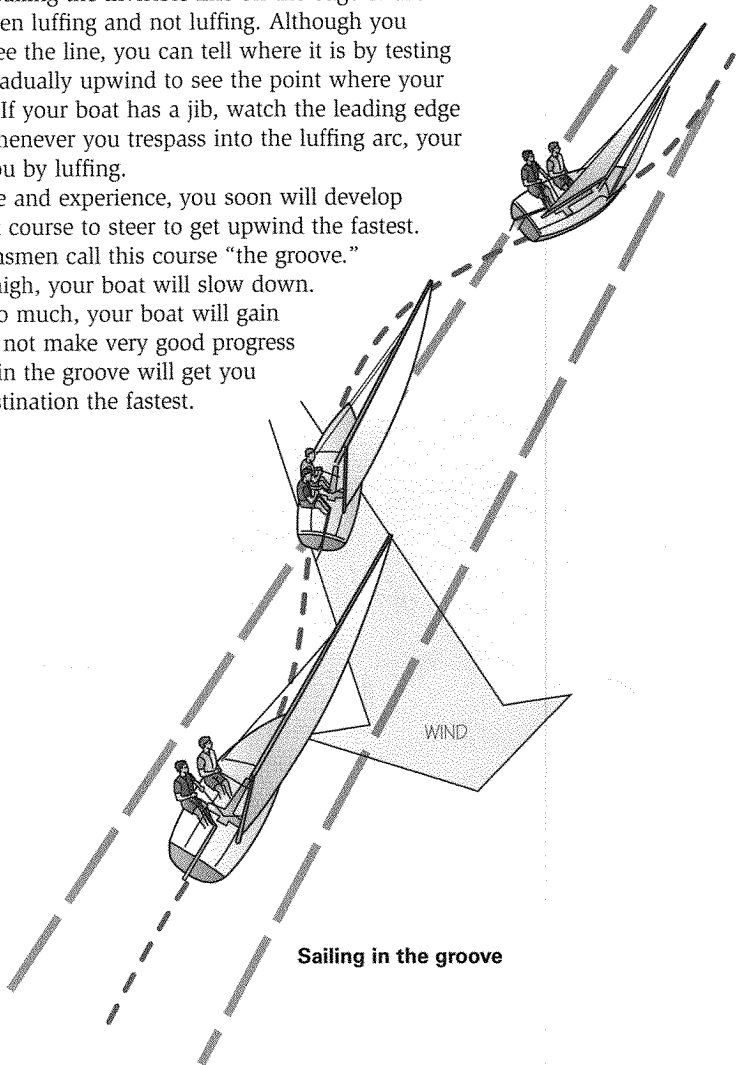

**Sailing in the groove**



# Marlinespike Seamanship

A *marlinespike* is a tool used by sailors for splicing line (rope) or loosening difficult knots. The term *marlinespike seamanship* refers to the uses of line on a boat.

## About Line

All sailboats need line. Line is used to anchor or tie a boat to a dock or mooring. Line is used to hoist, trim, and adjust sails. Line is also used in emergencies to tow a disabled boat, to make temporary repairs, or to lash down loose gear in a storm.

Modern line used on boats today is made of plastic, which lasts longer and is stronger than the natural fibers (cotton, linen, and hemp) used in the past.

**Synthetic (plastic) line should be cut with a hot knife, a tool designed to melt through the fibers rather than cut them. At the same time it seals the ends so the line does not fray.**

Some types of line are better suited to particular tasks than others. There are three major features to consider when selecting line: material, construction, and tensile strength.

The two types of plastic line you are likely to use most are nylon and polyester. Nylon is less expensive and a bit stronger than polyester, but polyester is more stable. Each has its place on a sailboat.

Nylon is best used for anchor, dock, and mooring lines. Nylon is quite strong, and under heavy loads it can stretch up to 10 percent. Its elasticity absorbs the constant tensioning and

---

A line that is devoted to a particular task has a specific name such as *halyard*, *sheet*, or *anchor line*.

---

easing of a boat rocking, rising, and falling in choppy sea conditions. Nylon's natural elasticity helps to ease the strain on deck hardware (cleats), and it improves the holding power of anchors.

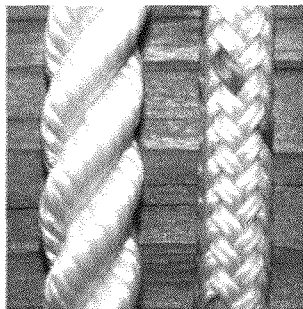

Polyester is popular for all running rigging because of its low stretch. When you hoist or trim in a sail, you want it to stay put, not stretch back toward where it started.

There are two main types of construction used in line making: three-strand twist (shown here at *left*) and braided (shown here at *right*).

Three-strand twist allows for more stretch, so it is mainly used to enhance nylon's elasticity. Braided construction minimizes stretch, so it is mainly used with polyester to reduce elasticity.

A line's tensile strength is based on the load it can take without breaking. Tensile strength increases with thickness.

A slight increase in thickness provides a large increase in tensile strength but also an increase in cost. However, it is a good safety practice to use line that has several times the tensile strength you might ever expect to need.

Clean line works better and lasts longer. Sand and grit weaken line by gradually grinding away the fibers. Dirt and grit also transfer to turning blocks and other fittings, preventing them from working properly. Oils can make line slippery and dangerous to handle. Remove sand, dirt, mud, and oils by regularly rinsing lines in fresh water with detergent.

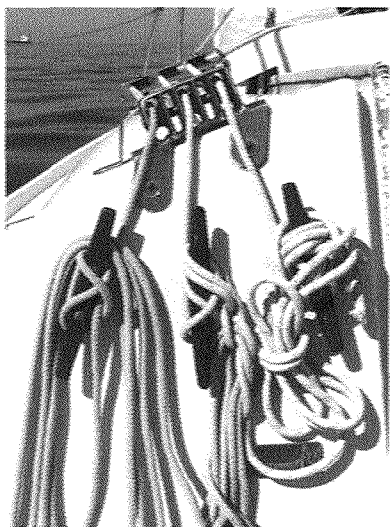

To keep lines untangled and out from underfoot, coil them neatly. Hang longer lengths of line such as halyards.



## Knots

There are dozens of knots you could learn, but you can handle nearly any chore on a small sailboat with just a few: the cleat hitch, bowline, square knot, clove hitch, figure-eight knot, and two half hitches.

A cleat hitch is used to secure a line to a cleat, which is used to fasten a line under a load. Three types of cleats typically are found on small sailboats: deck cleat (sometimes called a horned cleat), jam cleat, and cam cleat.

A deck cleat is usually bolted firmly to a deck or dock to provide a place to secure a mooring line. Most of the load from the line is taken up and held by the full turn around its base (1). The remainder is held secure by a crisscrossing figure eight around the two horns and over the top (2).

The cleat hitch is locked off by a final half hitch (3). When done properly, a top view of a cleat hitch should show two parallel lines crossed over by one (4).

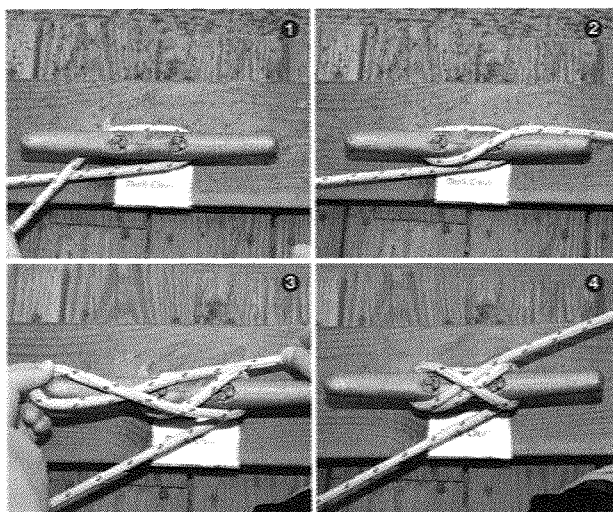
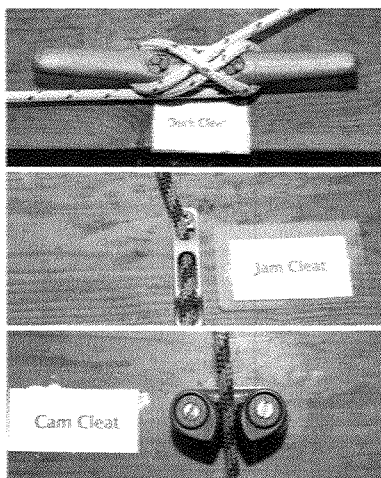

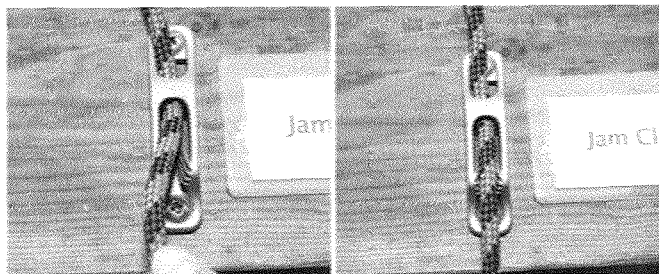

A jam cleat is used for quick release under light loads, such as with outhauls or cunninghams. A very heavy load could cause too much strain for a quick release.

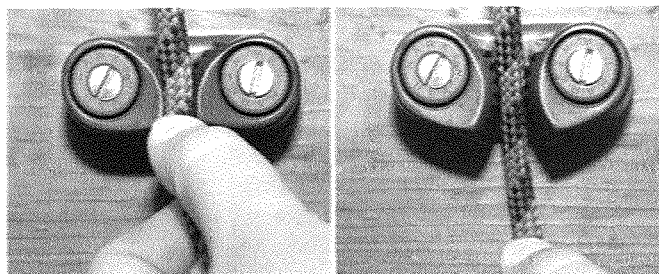

A cam cleat is designed for quick release, particularly with sheets. The two cams are spring loaded to squeeze together. The teeth grip the line and channel it into the narrow space between the cams, where it becomes wedged securely. To release line in a cam cleat, you merely lift up.

The dependable bowline (pronounced *boe'-linn*) makes a secure loop in a line. It will not slip, and it easily unties after heavy loading. It can be used for a variety of purposes such as tying up to a post or rail, bending on sheets and halyards, or securing gear in rescues and emergencies.

The figure eight is a stopper knot and gets its name from its resemblance to the numeral 8. It is used commonly on sailboats

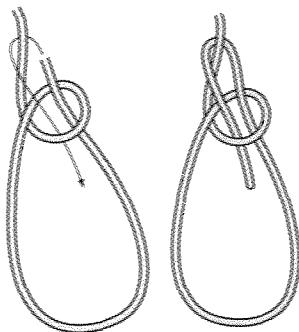

For help with remembering how to tie the bowline knot correctly, memorize this saying: "The rabbit comes out of his hole, goes around the tree, and then goes back into his hole."

to put a lump in the end of a piece of running rigging to stop it from slipping through a fairlead or a turning block. It is good practice while rigging to double-check that all lines of the running rigging, particularly sheets, have their figure eights well-secured before raising sails. For security they should be tied two or three inches from the end of the line.

The square knot is used to join two lines of equal thickness together. To tie a square knot correctly, put one line in each hand and remember the expression, "right over left, then left over right." Otherwise you might make a mistake and tie a granny knot. Granny knots are much harder to untie after they are pulled tight under heavy loading.

The clove hitch is often used as a quick and easy way to temporarily tie up a dinghy to a post or rail. A clove hitch can work its way loose over time. Because a boat bobs up and down over waves, a boat tied up with a clove hitch should not be left unattended for long.

Two half hitches are used to secure a line around a post or ring. They are easy and quick to tie and are a good alternative to the clove hitch.

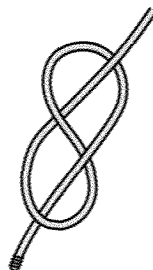
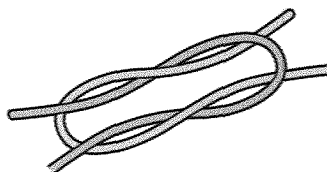
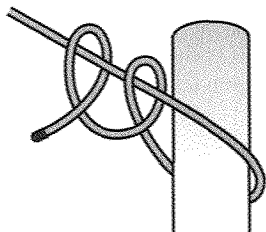

Figure eight



The square knot is sometimes called a reef knot.



Two half hitches

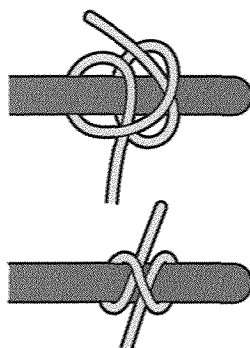

Clove hitch

## Coiling and Heaving Line

Occasionally you may need to heave (toss) and pay out coiled line to a dockhand, a tow boat, or an overboard victim. It is a good idea to practice coiling and heaving line on shore.

Line should be coiled clockwise (with the lay of the line) in loops of equal size. Proper coiling helps make sure that the line will pay out smoothly without tangling and falling short of the mark.

To heave a coiled line, split the coil in half. Hold half in each hand. With the heaving arm straight down by your side, swing it slowly forward and backward without bending your elbow. The coil should remain in a straight line extension of your arm. Swing the line backward then forward to gain momentum, and release the coil when your hand is about shoulder height. The goal is to have the line extend fully in an arc and arrive untangled at its target.

Let the line pay out of your opposite hand. The end of the line needs to be secured, either to the boat, the dock, or with a loose loop around your wrist.

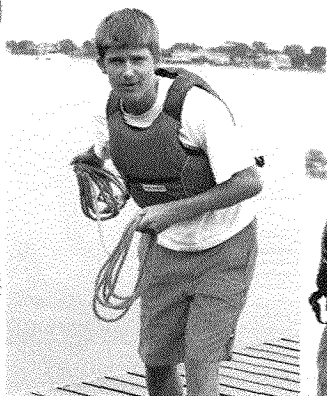
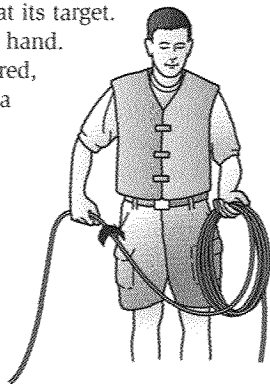

## Faking Down Line

*Faking* is a form of coiling where the line is laid down on a deck or cockpit and the coils are placed one on top of the other in a figure-eight pattern. Faking down a line, rather than simply coiling it, is usually done when a longer line needs to be paid out quickly and without tangling, such as when anchoring in unusually deep water.

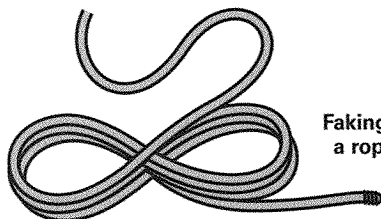

**Faking down  
a rope**

Faking down line was a matter of life and death on whaling boats of the early 19th century. After being harpooned, a whale would often dive. The line attached to the harpoon would have to run out quickly and reliably from the cockpit or the whale could pull the boat under, drowning the whalers. Faking down the harpoon lines was entrusted to only the most reliable crew members.

# Rules of the Road

The purpose of the rules of the road is to promote safety and to prevent collisions. It is essential that all boaters learn and follow these navigation rules.



When two boats approach one another and there is a risk of collision, the right-of-way rules apply.

## Right-of-Way

The stand-on vessel, with the right-of-way, is free to continue on its course. A vessel without the right-of-way, the give-way vessel, has the responsibility to take action to avoid any collision.

When two sailboats meet and neither is using an engine, there are three primary rules of the road:

- **Opposite tacks.** When two sailboats on opposite tacks meet, the one on starboard tack is the stand-on vessel and has the right-of-way.

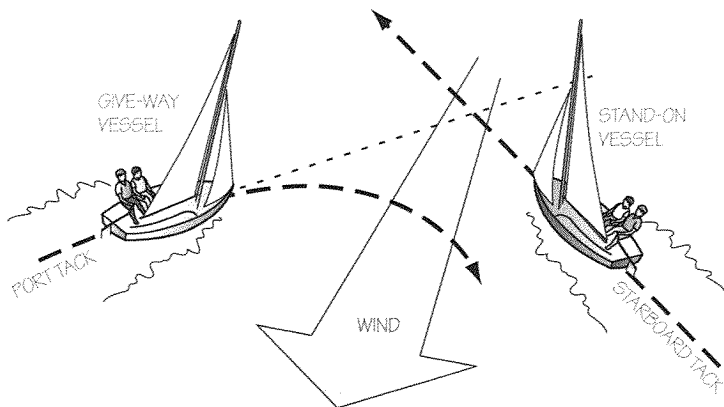



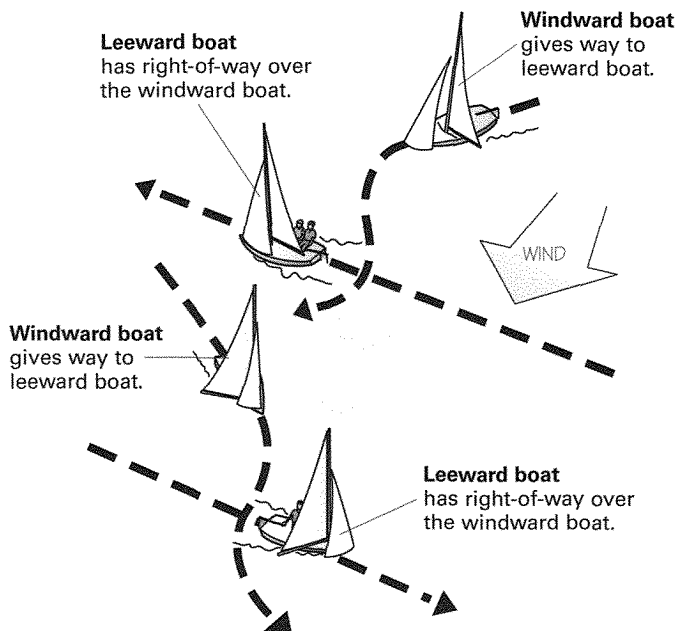

- **Same tack.** When two sailboats on the same tack meet, the one on the leeward (downwind) side is the stand-on vessel and has the right-of-way.
- **Overtaking.** When a faster-moving sailboat overtakes another from behind, it is the give-way vessel and must keep clear of the boat it is overtaking.

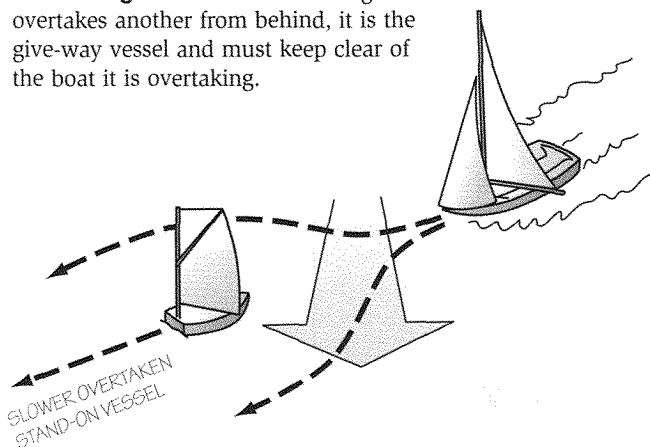

When you encounter other boats, it is important to know that there are different right-of-way rules for motorboats, sailboats, and muscle-powered craft (canoes, rowboats, kayaks, etc.). In general, motorboats have to keep clear of sailboats—but not always. In general, both sailboats and motorboats must keep clear of muscle-powered craft—but not always.

Here are some exceptions.

- All boats must keep clear of disabled vessels except to render assistance.
- All boats must yield to vessels restricted in their ability to maneuver, such as barges or commercial fishing boats engaged in fishing.
- In narrow channels, smaller boats must yield to ships and deep-draft vessels that can operate only in the channel.
- Any vessel overtaking another must keep clear of the overtaken vessel.
- A sailboat that is using an engine is considered a powerboat and must follow powerboat rules.

It is a good idea to boat defensively, that is, simply avoid other boats even when you have the right-of-way. Other boaters may not understand the rules as well as you. They may not be alert, or they may not be very skilled at boat handling. You can increase your personal safety simply by staying well clear of other vessels.

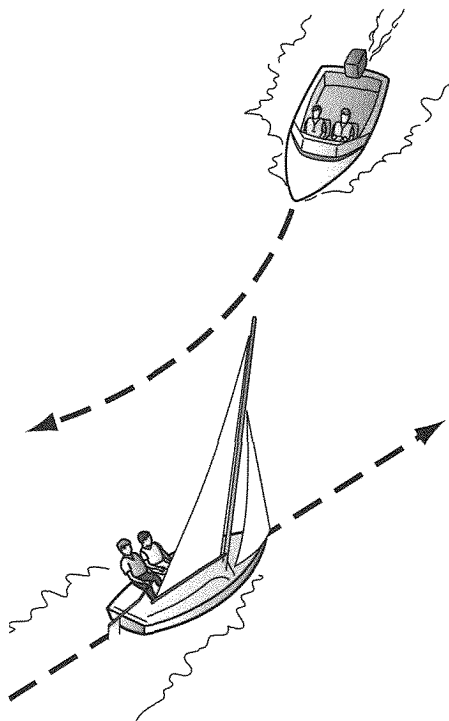

There are a number of additional rules that apply only to sailboats that are racing. The above rules are fundamental and apply to all sailboats, whether or not they are racing. Even so, it is a common courtesy among casual sailors to yield to a boat that is actively racing. If you accidentally stray into a racecourse, try to not interfere with the wind of the boats that are racing.

## Responsible Sailing

- Wear a life jacket whenever you are on the water. Some states have laws requiring that children wear life jackets when a boat is under way. Check your state's laws.
- Check with your state boating law administrator's office for details about mandatory boater safety education laws.



- Stay away from swimming areas. They usually are marked by special buoys.
- Stay well clear of scuba-diving areas. They usually are marked by a red flag with a white diagonal stripe extending from corner to corner.
- Be mindful of the *wake* (waves) created by your boat. You are responsible for your wake damage to other people's property.
- Stow your trash for disposal ashore. It is against federal law to throw anything made of plastic overboard.
- Check local laws before flushing marine heads (toilets) overboard. In many places it is illegal.
- Never tie up to a channel or regulatory marker. It is against the law.
- Always offer help to another boat in distress unless it puts you in danger.

For further information about boating rules, check with local police, the U.S. Coast Guard Auxiliary, or a local unit of the U.S. Power Squadron. You may also view the U.S. Coast Guard's navigation rules page on the World Wide Web (with your parent's permission). See the resources section in the back of this pamphlet.



# Emergencies

Being prepared to handle emergencies while sailing makes activities on the open water safer and more fun for everyone.

Considerate and courteous sailing includes rendering assistance promptly to those in trouble or distress and in all respects being faithful to the customs and traditions of the sea.

A life jacket can  
save your life—  
but only if  
you wear it.

## Capsizing

A sailboat *capsizes* when it heels over so far that the top of the mast touches the water. Capsizes can occur on small boats when:

- The sails are trimmed in too far.
- The wind is too strong.
- The boat is carrying too much sail area.
- The crew members do not use their weight correctly to balance the hull.

Capsizing in a small sailboat is not necessarily a crisis. Well-trained sailors sometimes capsize for practice or just for fun on a hot day. Rehearsing what to do in safe and controlled conditions can pay off someday in a true capsize emergency.

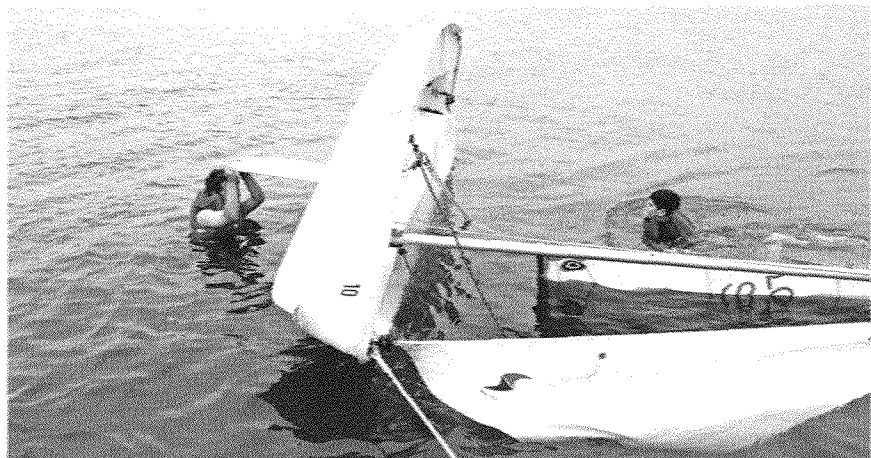

The biggest danger in capsizing is the possibility of drowning, but that danger can be greatly reduced if everyone on board routinely wears a properly sized and fitted life jacket.

To avoid capsizing, sail with main sheet uncleated and be ready to shift your weight.

MOVE WEIGHT OUT BY HIKING TO  
COUNTERACT HEELING.

SHEET OUT JIB IF  
NECESSARY.

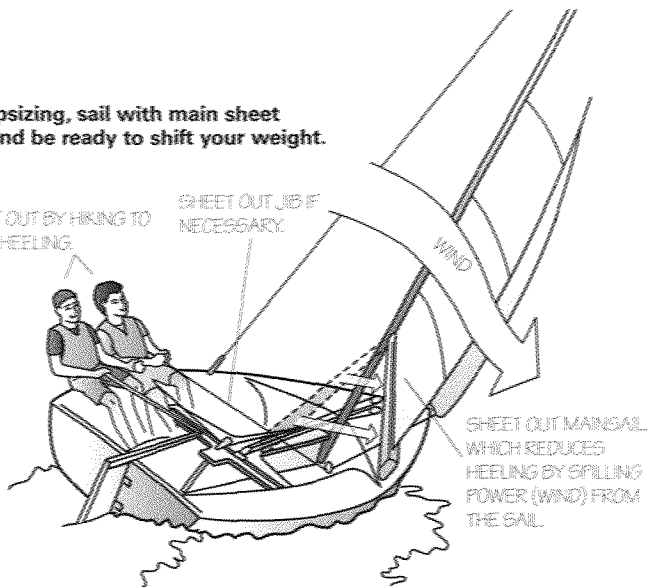



Always stay with a capsized boat even if you do not think you can right it. The hull, even if completely *turtled* (upside down), provides flotation much like a life raft. In addition, rescuers are more likely to find you and the hull if you remain together. Do not try to swim to shore. Distances on the water can be much greater than they appear, and you might get tired out or suffer hypothermia before you reach shore. If the water is cold, climb atop the boat while waiting for help.



### Capsize Recovery

When a boat capsizes, first count heads, that is, locate all crewmates and be sure everyone is present, uninjured, and wearing a life jacket. When all hands are accounted for, then it is time to right the boat. Remember: People first, boat second.

Follow these steps for capsize recovery.

**Step 1**—Count heads. Account for all crew members. Make sure no one is trapped beneath the sail.

**Step 2**—Stay with the boat. Do not swim away.

**Step 3**—Release all sheets from their cleats.

**Step 4**—Turn (swim) the hull to point it into the wind.

**Step 5**—Swim to the centerboard/daggerboard.

**Step 6**—Pull down or stand on the tip to right the boat.

**Step 7**—Grab on to the hull before it drifts away.

**Step 8**—Climb on board.

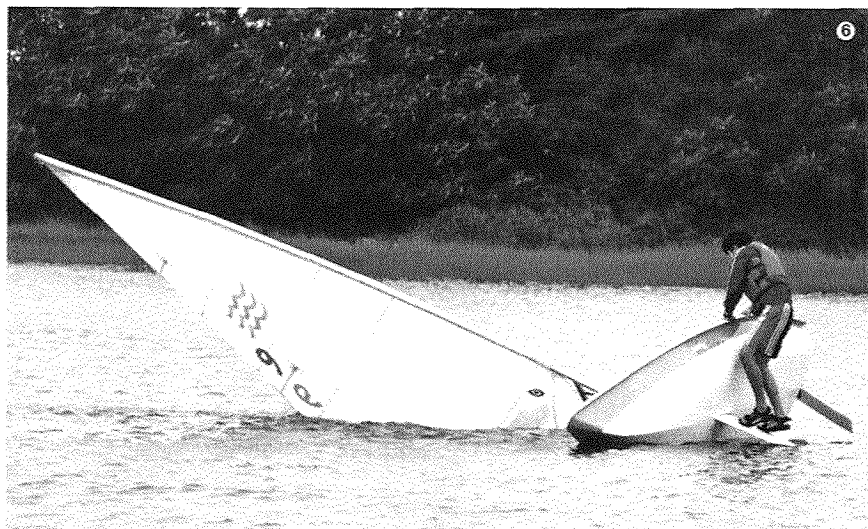

Before righting a capsized boat, release all sheets from their cleats. The sails should be free to luff as soon as the boat is righted so the boat does not capsize again or sail away from you. For the same reason it is important to turn the boat to the wind before righting it. It will help to keep the righted boat stationary until you can get back on board.

When you are ready to right the boat, pull down on the centerboard/daggerboard with all your weight. You will get maximum leverage at the very tip. As soon as the boat is righted, immediately grab onto it so it cannot drift off without you.

### Scoop Method Recovery

The scoop method is for boats with two crew members. The fundamental righting method described earlier is used with one difference: In the scoop method, one crew member pulls down on the centerboard and rights the boat while the crewmate is scooped up into the cockpit nearly effortlessly. The advantage of the scoop method is that after the boat is righted, only one crew member is left outside of the boat. The scooped crew member can then help the partner aboard.

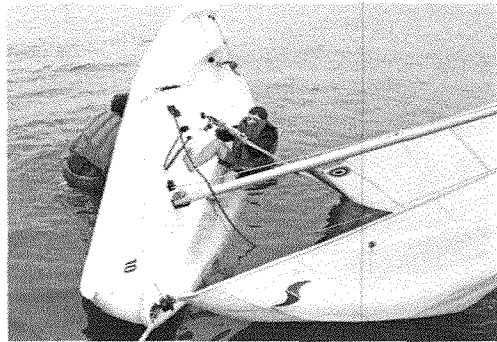
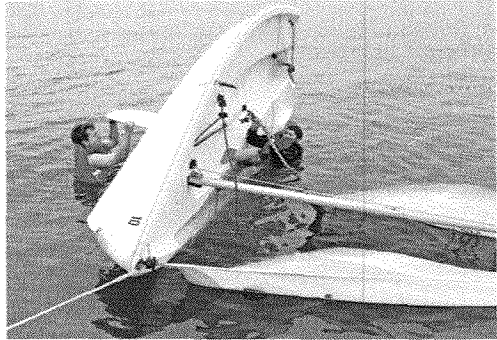

## Overboard Recovery

When a crew member goes overboard, choose one of the recovery methods below, based on the condition of the victim and how able he or she is to assist in the rescue.

If a crew member falls overboard while sailing, it is critically important for one person on board, the designated spotter, to maintain constant eye contact with the overboard victim—or the victim's last observed position. That person can point the way for the helmsman to steer to pick up the overboard crew member.

The approach to the victim should be from downwind on a close-reaching safety position. From a safety position, you can maintain slow speed for greater precision in approaching the victim. *Once you have made contact, do not let go. You might not get a second chance.*

Depending on the amount of freeboard (the height of the hull above the water), a simple arm pull or an extended paddle may be enough to retrieve a crew member. An alternative is

to pull a conscious crew member aboard by the life jacket. Be sure the jacket is well-fastened first, so you do not pull it off by accident. Reach in through the armholes and grab the shoulder straps, pulling up and back onto the boat. Another method is to tie a bowline in the end of a piece of line (a halyard or sheet will do). Dangle it into the water for the victim to use as a foothold. Be sure the inboard end is securely cleated.

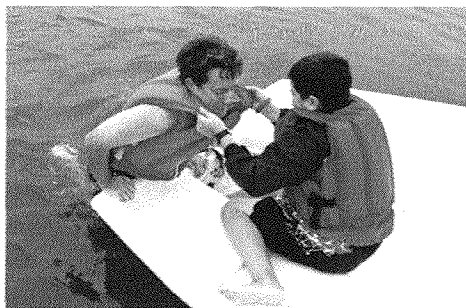

**It may be safer to bring an overboard victim in over the stern, where the boat is more stable.**

When bringing a victim onboard from the water, take care to avoid capsizing the rescue boat. If the rescuers all rush to one side to assist the overboard victim, the sudden shift of weight might tip the boat over.

## Running Aground

If you sail into waters where your boat's draft (depth below the waterline) exceeds the depth of the water, you will run aground. If you hit rocks, the boat could be damaged. If you hit a soft bottom of mud or sand, you may need only to shove off, refloat the boat, and be on your way again.

Although the water may be shallow, avoid stepping out of the boat. Do so only as a last resort. If the boat suddenly gets free and sails off, you will be stranded. Use an oar, paddle, or boat hook to shove off. If leaving the boat becomes absolutely necessary, hold onto it forward of the mast and be ready to jump on quickly if the boat suddenly starts to go. Holding the boat forward of the mast will allow you to keep the boat pointed into the wind, with sails luffing, until you are ready to get started again.

If you run aground, follow this procedure:

**Step 1**—Release all sheets so the sails fully luff.

**Step 2**—Turn the boat into the wind first, and then toward deep water.

**Step 3**—Raise the rudder blade and centerboard/daggerboard enough to free them.

**Step 4**—Push off, if necessary using an oar or pole.

**Step 5**—As you enter deeper water, lower your fins and resume sailing.



# Maintenance

## Keeping Shipshape

A shipshape boat has its hull and all its equipment clean, neat, and ready for action. Keeping all gear prepared and ready helps avoid problems. For example, if you need to anchor quickly in an emergency but the anchor line is tangled, the boat could drift into danger before you could untangle the line and set the anchor.



Two old sayings in sailing apply to keeping shipshape: "A place for everything and everything in its place." "Leave it better than you found it."

---

Do your best to keep the boat clean at all times, inside and out: the bilges free of water and dirt, the waterline and bottom free of marine growth, topsides free of marks and damage, and the cockpit and decks free of loose gear.

---



Do the following routinely after any sail:



**Step 1**—Rinse and wipe the boat clean of any dirt, debris, or footprints.

**Step 2**—Pump, bail, drain, or sponge-dry the hull.

**Step 3**—Secure all running rigging by pulling it taut and cleating it.

**Step 4**—Neatly coil longer lines such as halyards, sheets, and mooring lines so they can run freely without snags or kinks the next time they are used. Never leave line where it can be stepped on.

**Step 5**—Stow or remove loose gear from the boat.

**Step 6**—Dry out and neatly roll, furl, or flake sails.

**Step 7**—If the boat has been in seawater, rinse it well—particularly the metal and moving parts.

**Step 8**—Secure the sail and boat covers to keep them in place during harsh weather.

**Step 9**—For security and to prevent chafe, properly cleat all mooring or dock lines, and use fenders as needed.



## Preventing Corrosion

Sailboats have a variety of metal parts and fittings. For example, standing rigging, chain plates, and tangs hold the mast up; cleats, blocks, and fairleads help control the running rigging; and deck cleats and chocks are used to tie the boat up at a dock or mooring. We depend on metal parts to remain strong, but nearly all metals naturally corrode over time, especially when close to water and humidity.

When air and water are present, they can cause a type of corrosion called *oxidation*, in which a chemical change takes place on metal surfaces, often discoloring the metal. Rust is a familiar form of oxidation that occurs on iron and steel and turns the surface reddish brown. When copper oxidizes, it turns green. When aluminum oxidizes, it turns white. If left alone, oxidation will gradually cause metal to disintegrate.

Sailboat parts are usually made of metals that resist oxidation such as stainless steel and special types of aluminum. If you need to replace or add any metal parts to your boat, be sure to get them from a store that sells marine-grade hardware—hardware made especially for boats.

Electrolysis is a type of corrosion that occurs when two different metals react with one another. When different metals come into contact, particularly when moisture is present, one of them will gradually disintegrate. Sometimes metal parts that are simply near each other, not even touching, can react if they are underwater. Electrolysis is a slow process that may lead to gear failure weeks, months, or even years after it begins.

### Oxidation-Fighting Tips

- Use only marine-grade hardware and fasteners on your boat.
- Keep metal parts dry when not in use.
- Coat all moving parts (turning blocks, traveler, gooseneck, etc.) with a light coat of spray lubricant weekly or as needed.

### Fiberglass Care

Reinforced fiberglass is strong and durable. It will last for many years with little or no maintenance. However, the polyester gel coat that gives it its colorful, shiny finish needs some attention.

Over time the color of the gel coat may fade, and the shine may turn dull. You can restore the color and shine with a two-step process.



**Step 1**—Apply a marine fiberglass cleaner that contains oxalic acid. The oxalic acid will restore color instantly without scrubbing. Rinse and wipe the surface thoroughly with fresh water until all traces of the cleaner are removed.

**Step 2**—Apply a marine polish. This will restore the shine and improve the color. Be sure to rub it in well. The polish will help protect the finish from future discoloration.

## Electrolysis-Fighting Tips

- Only use fasteners (screws, bolts, nuts, rivets, etc.) that are made of the same metal as the fitting you are installing. For example, if the fitting is stainless steel, use only stainless steel fasteners with it.
- Never mix fasteners of two different metals. If a bolt is brass, for example, use only a brass nut and washer to go with it.
- When installing or replacing a stainless-steel fitting on an aluminum spar, put a piece of tape between the fitting and the spar to serve as a barrier from direct surface-to-surface contact.
- Rinse off seawater thoroughly immediately after returning from sailing. Salt speeds electrolysis.
- Do not leave any metal immersed in water needlessly. Keep bilges pumped dry, outboard engines tilted up, and metal equipment (anchors, chain, boat hooks, etc.) out of standing water.
- Coat all moving parts with a light film of spray lubricant.

## Fouling

Marine growth, such as barnacles and slime, will grow on a boat's bottom within a few days if a boat is left in the water at a dock or mooring and not hauled out. This growth, or *fouling*, will significantly slow a boat because it causes drag. Fouling gets worse the longer a boat remains in the water unprotected.

Boats left in the water at a mooring or marina slip need to have their bottoms coated with antifouling paint, which discourages marine growth. The paint needs to be reapplied once or twice annually depending on the location and length of the boating season. Antifouling paint is poisonous and should never be applied to anything other than boat bottoms. When you use it, be sure to follow the directions printed on the label and observe all the precautions. Wear gloves while applying it, and clean up carefully after using it.



# History of Sailing in America

Sailing has been a part of our history since the first European explorers sailed to the Americas. Christopher Columbus sailed across the Atlantic Ocean in 1492 and claimed the land he found in the name of Spain. In the centuries that followed, the navies of England, France, Spain, and other countries crossed the ocean in square-rigged sailing ships to trade, plunder, explore, and conquer.

For nearly 400 years, trade among the early colonizers and their European suppliers and investors was entirely dependent on sailing ships. The ships transported goods and people across thousands of miles of ocean. Skilled sea captains were well-paid and highly respected. Early colonizers also depended on sailing ships to catch fish; hunt whales; and trade food, raw materials, and manufactured goods along the coastal settlements. The small villages of centuries ago eventually grew into today's thriving seaport cities.

The invention of the steam engine in the 19th century nearly made sailing ships a thing of the past. Sailing ships could not keep up with steamships with paddlewheels and the propeller-driven ships with internal-combustion engines that were later developed. For carrying cargo, motorized ships were far faster and cheaper to operate than sailing ships. Today, virtually all trading ships are powered by engines and propellers rather than wind and sails. Sailing is now strictly for sport and recreation.

## Competitive Sailing

In the early days of sport sailing, sailboat racing (originally known as yachting) was only for the rich. Only the wealthiest people could afford to build large, fast sailboats and pay a professional crew. In those days, sailing skill did not necessarily win regattas. The competitors with the bigger, faster boats generally took home the prizes.

The oldest ongoing sports competition event in the world is the America's Cup sailing competition. It began in 1852 as a challenge between the Royal Yacht Squadron in England and the New York Yacht Club in the United States. Today the competition continues, but a number of other countries also compete for the cup.



**Among many racing sailors, the America's Cup is still considered the ultimate prize in the world. It is named after the vessel *America*, which won the first race.**

## One-Design Classes

In the early 20th century, the first one-design sailboat, the Star, was introduced. It revolutionized the sport. The 23-foot Star was small by America's Cup standards. Yet because each one was built exactly alike, no one had an advantage over any other Star sailor. Only a sailor's skill made the difference between who won and lost, not the size of the racer's boat or bank account.

The Star was the first, but many more one-design classes followed. Today there are hundreds of classes, big and small, each built to exacting standards for fair racing among people of ordinary means. No longer called yachting, sailboat racing, particularly one-design racing, has become an affordable pastime that evolved into an Olympic sport in the mid-20th century.



## Waterfront Access

As small sailboats caught on, the sport got an additional boost by the country's new and growing network of high-speed interstate highways. The highways gave many people quicker and easier access to lakes, rivers, beaches, and marinas. The need for sailing instruction grew almost instantly, and community sailing programs started popping up all over.

## US Sailing Association

The US Sailing Association, better known as US SAILING, is the national governing body that selects, trains, and helps finance the Olympic campaigns of the country's top sailing athletes. It also governs sailboat racing rules and procedures and develops training programs for instructors.

For recreational sailors, US SAILING offers a national credential, *Small Boat Sailor Certification*, with multiple levels of achievement. The starting point is a small inexpensive booklet, the *Small Boat Sailor Certification Record Book*, widely known as "The Little Red Book." It lists the skills required for certification by US SAILING, skills that closely match the ones described in this pamphlet.





# Small-Boat Sailing Resources

## Scouting Literature

*Deck of First Aid; Emergency First Aid pocket guide; Be Prepared First Aid Book; Fieldbook; Sea Scout Manual; Canoeing, Kayaking, Motorboating, Rowing, Scuba Diving, and Whitewater merit badge pamphlets*

With your parent's permission, visit the Boy Scouts of America's official retail website, [www.scoutshop.org](http://www.scoutshop.org), for a complete listing of all merit badge pamphlets and other helpful Scouting materials and supplies.

## Books

Aarons, Richard N., ed. *Small-Boat Seamanship Manual*. International Marine/Ragged Mountain Press, 2006.

Ashley, Clifford. *Ashley Book of Knots*. Doubleday, 1944.

Bond, Bob. *The Handbook of Sailing*. Knopf, 1992.

Fries, Derrick. *Start Sailing Right!* US Sailing Association, 1997.

Isler, Peter, and J.J. Isler. *Sailing for Dummies*, 2nd ed. Wiley Publishing Inc., 2006.

Kantor, John. *Basic Sailing*. Longshore Sailing School ([www.LongshoreSailingSchool.com](http://www.LongshoreSailingSchool.com)), 2004.

Maloney, Elbert S. *Chapman Piloting and Seamanship*, 68th ed. Hearst Corporation, 2017.

Rousmaniere, John. *Annapolis Book of Seamanship*, 4th ed. Simon & Schuster, 2014.

Royce, Patrick. *Royce's Sailing Illustrated*. Royce Publications, 1997.

Smith, Hervey Garrett. *The Marlinspike Sailor*, 2nd ed. Martino Fine Books, 2012.

US Sailing Association. *Small Boat Sailor Certification Record Book* ("The Little Red Book"). US Sailing Association, 2001.

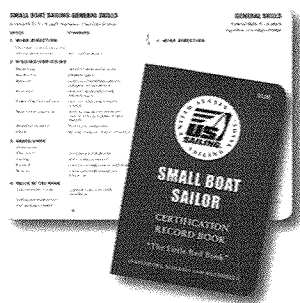

## Magazines

### **Blue Water Sailing**

747 Aquidneck Ave., Suite 201  
Middletown, RI 02842  
Toll-free telephone: 888-800-7245  
Website: [www.bwsailing.com/bw](http://www.bwsailing.com/bw)

### **Sail**

10 Bokum Road  
Essex, CT 06426  
Toll-free telephone: 800-745-7245  
Website: [www.sailmagazine.com](http://www.sailmagazine.com)

### **Sailing**

Website: [www.sailingmagazine.net](http://www.sailingmagazine.net)

### **Sailing World**

55 Hammarlund Way  
Middletown, RI 02842  
Toll-free telephone: 866-436-2460  
Website: [www.sailingworld.com](http://www.sailingworld.com)

## Organizations and Websites

### **American Sailing Association**

5301 Beethoven St., Suite 265  
Los Angeles, CA 90066  
Telephone: 310-822-7171  
Website: [www.asa.com](http://www.asa.com)

### **Online Small Boat Sailing Course**

Website: [www.asa.com/online-sailing-course](http://www.asa.com/online-sailing-course)

### **U.S. Coast Guard: Boating**

Website: [www.uscgboating.org](http://www.uscgboating.org)

### **US SAILING Association**

1 Roger Williams University Way  
Bristol, RI 02809  
Toll-free telephone: 800-877-2451  
Website: [www.ussailing.org](http://www.ussailing.org)

## Acknowledgments



The Boy Scouts of America thanks the United States Sailing Association, better known as US SAILING, the national governing body for the sport of sailing in the United States, for its generous permission to pattern our how-to illustrations after those in its official learn-to-sail guide, *Start Sailing Right!* Thanks also to the following US SAILING employees and volunteers.

- Janine Connelly, US SAILING Training Director
- Pat Giella, US SAILING Instructor Trainer and National Faculty member
- Jo Mogle, US SAILING Training Committee Vice Chair for Standards and Credentials
- Richard Jepsen, US SAILING Training Committee Chair and CEO OCSC Sailing School
- Timmy Larr, US SAILING Training Committee volunteer

The BSA also appreciates the assistance of Scouter David Bell, BSA Health and Safety Committee member.

The Boy Scouts of America is grateful to the men and women serving on the National Merit Badge Subcommittee for the improvements made in updating this pamphlet.

The Boy Scouts of America thanks John Kantor, Longshore Sailing School president and US SAILING Instructor Trainer and national faculty member, for his invaluable help with writing this edition of the *Small-Boat Sailing* merit badge pamphlet. The BSA greatly appreciates his expertise and involvement. Longshore Sailing School, based in Westport, Connecticut, is among the largest, oldest, and most respected community sailing programs in the United States. Many of the photos in this pamphlet were taken there.



Longshore  
Sailing School

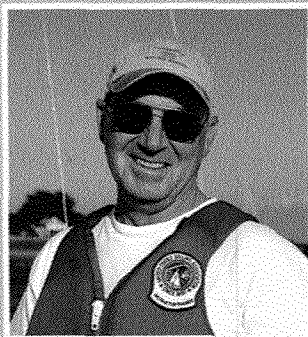

### Photo and Illustration Credits

HAAP Media Ltd., courtesy—  
cover (*clouds, rope*)

John Kantor, courtesy—page 95

Shutterstock.com, courtesy—cover  
(*sunglasses and hat, ©Pla2na*); page  
18 (*cumulus clouds, ©PJjaruwan*)

Wikipedia.org, courtesy—pages 18  
(*cirrostratus, altostratus, and  
stratocumulus clouds*) and 19  
(*cirrus, cirrocumulus, altocumulus,  
cumulonimbus, and stratus clouds*)

All other photos and illustrations not mentioned above are the property of or are protected by the Boy Scouts of America.

Dan Bryant—cover and page 14 (*type  
III life jacket*)

Sam Kolich—cover (*sailboat on right*)

John McDearmon—all illustrations

Brian Payne—pages 14 (*types I and II  
life jackets*) and 15 (*flotation pad*)

Randy Piland—cover (*sailboat at left*);  
pages 6, 21, 32, 74, 88, and 91





## MERIT BADGE LIBRARY

Though intended as an aid to Boy Scouts, and qualified Venturers and Sea Scouts in meeting merit badge requirements, these pamphlets are of general interest and are made available by many schools and public libraries. The latest revision date of each pamphlet might not correspond with the copyright date shown below, because this list is corrected only once a year, in January. Any number of merit badge pamphlets may be revised throughout the year; others are simply reprinted until a revision becomes necessary.

If a Scout has already started working on a merit badge when a new edition for that pamphlet is introduced, they may continue to use the same merit badge pamphlet to earn the badge and fulfill the requirements therein. In other words, the Scout need not start over again with the new pamphlet and possibly revised requirements.

Merit Badge Pamphlet	Year	Merit Badge Pamphlet	Year	Merit Badge Pamphlet	Year
American Business	2013	Family Life	2016	Plant Science	2018
American Cultures	2013	Farm Mechanics	2017	Plumbing	2012
American Heritage	2013	Fingerprinting	2014	Pottery	2008
American Labor	2018	Fire Safety	2016	Programming	2013
Animal Science	2014	First Aid	2015	Public Health	2017
Animation	2015	Fish and Wildlife Management	2014	Public Speaking	2013
Archaeology	2017	Fishing	2013	Pulp and Paper	2013
Archery	2015	Fly-Fishing	2014	Radio	2017
Architecture and Landscape Architecture	2014	Forestry	2015	Railroading	2015
Art	2013	Game Design	2013	Reading	2013
Astronomy	2016	Gardening	2013	Reptile and Amphibian Study	2018
Athletics	2016	Genealogy	2013	Rifle Shooting	2012
Automotive Maintenance	2017	Geocaching	2016	Robotics	2016
Aviation	2014	Geology	2016	Rowing	2014
Backpacking	2016	Golf	2012	Safety	2016
Basketry	2017	Graphic Arts	2013	Salesmanship	2013
Bird Study	2017	Hiking	2016	Scholarship	2014
Bugling (see Music)		Home Repairs	2012	Scouting Heritage	2017
Camping	2018	Horsemanship	2013	Scuba Diving	2009
Canoeing	2014	Indian Lore	2008	Sculpture	2014
Chemistry	2018	Insect Study	2018	Search and Rescue	2018
Chess	2016	Inventing	2016	Shotgun Shooting	2013
Citizenship in the Community	2015	Journalism	2017	Signs, Signals, and Codes	2015
Citizenship in the Nation	2014	Kayaking	2016	Skating	2015
Citizenship in the World	2015	Landscape Architecture (see Architecture)		Small-Boat Sailing	2016
Climbing	2011	Law	2011	Snow Sports	2017
Coin Collecting	2017	Leatherwork	2017	Soil and Water Conservation	2016
Collections	2013	Lifesaving	2017	Space Exploration	2016
Communication	2013	Mammal Study	2014	Sports	2012
Composite Materials	2012	Medicine	2012	Stamp Collecting	2013
Cooking	2014	Metalwork	2012	Surveying	2004
Crime Prevention	2012	Mining in Society	2014	Sustainability	2013
Cycling	2017	Model Design and Building	2010	Swimming	2014
Dentistry	2016	Motorboating	2015	Textile	2014
Digital Technology	2014	Moviemaking	2013	Theater	2014
Disabilities Awareness	2016	Music and Bugling	2013	Traffic Safety	2016
Dog Care	2016	Nature	2014	Truck Transportation	2013
Drafting	2013	Nuclear Science	2017	Veterinary Medicine	2015
Electricity	2013	Oceanography	2012	Water Sports	2015
Electronics	2014	Orienteering	2016	Weather	2013
Emergency Preparedness	2015	Painting	2016	Welding	2016
Energy	2014	Personal Fitness	2016	Whitewater	2005
Engineering	2016	Personal Management	2015	Wilderness Survival	2012
Entrepreneurship	2013	Pets	2013	Wood Carving	2016
Environmental Science	2015	Photography	2016	Woodwork	2011
Exploration	2016	Pioneering	2017		

## BOY SCOUTS OF AMERICA • SUPPLY GROUP

### NATIONAL DISTRIBUTION CENTER

2109 Westinghouse Boulevard  
P.O. Box 7143  
Charlotte, NC 28241-7143

To place an order,  
call customer service  
toll-free 800-323-0736  
or go to  
[www.scoutshop.org](http://www.scoutshop.org)



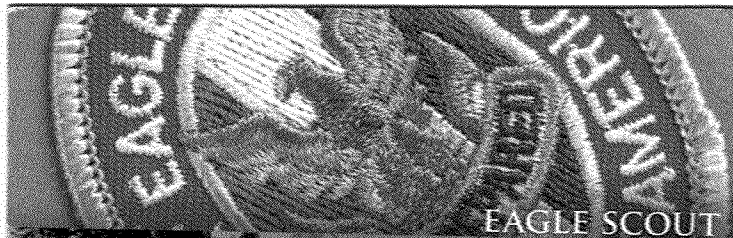

EAGLE SCOUT



THE SUMMIT



FLORIDA SEA BASE

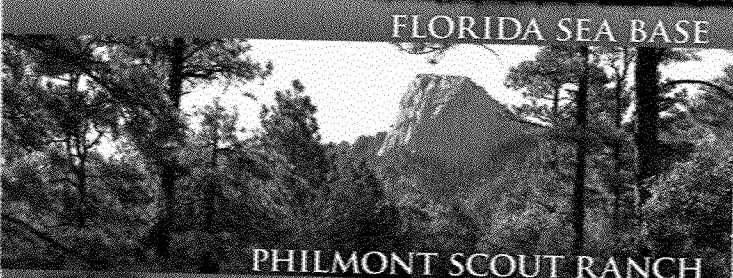

PHILMONT SCOUT RANCH

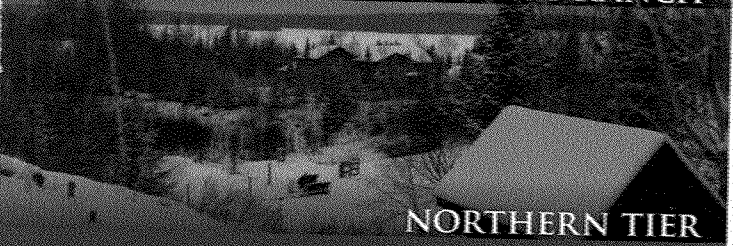

NORTHERN TIER

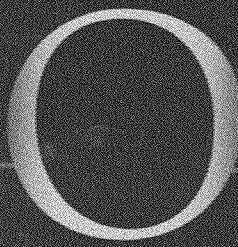

ON THE ROAD TO  
HIGH ADVENTURE

THE SUPPLY GROUP IS  
READY TO BE A PARTNER  
ON YOUR TRAIL TO  
EAGLE THROUGH HIGH  
ADVENTURE. THE  
ADVENTURE IS YOURS.  
AND WE ARE READY  
WITH THE GEAR YOU  
WILL NEED. YOU CAN  
DEPEND ON THE LATEST  
IN LIGHTWEIGHT,  
DURABLE, QUALITY  
GEAR THAT WILL  
MEET AND SURPASS  
YOUR TOUGHEST  
REQUIREMENTS.



[WWW.SCOUTSHOP.ORG](http://WWW.SCOUTSHOP.ORG)

SKU 649749



35950

2019 Printing



Certified Sourcing  
[www.sfi-program.org](http://www.sfi-program.org)  
94-0058