

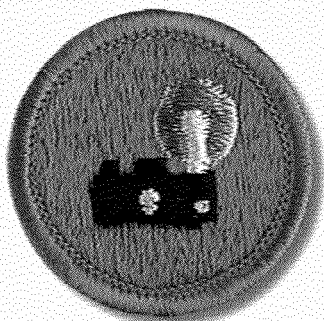

MERIT BADGE SERIES

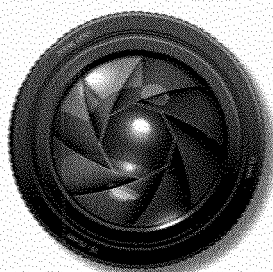

PHOTOGRAPHY



BOY SCOUTS OF AMERICA



How to Use This Pamphlet

The secret to successfully earning a merit badge is for you to use both the pamphlet and the suggestions of your counselor.

Your counselor can be as important to you as a coach is to an athlete. Use all of the resources your counselor can make available to you. This may be the best chance you will have to learn about this particular subject. Make it count.

If you or your counselor feels that any information in this pamphlet is incorrect, please let us know. Please state your source of information.

Merit badge pamphlets are reprinted annually and requirements updated regularly. Your suggestions for improvement are welcome.

Who Pays for This Pamphlet?

This merit badge pamphlet is one in a series of more than 100 covering all kinds of hobby and career subjects. It is made available for you to buy as a service of the national and local councils, Boy Scouts of America. The costs of the development, writing, and editing of the merit badge pamphlets are paid for by the Boy Scouts of America in order to bring you the best book at a reasonable price.

Send comments along with a brief statement about yourself to
Pilots and Program Development, S272

Boy Scouts of America • 1325 West Walnut Hill Lane • Irving, TX 75038
If you prefer, you may send your comments to merit.badge@Scouting.org.

BOY SCOUTS OF AMERICA
MERIT BADGE SERIES

PHOTOGRAPHY

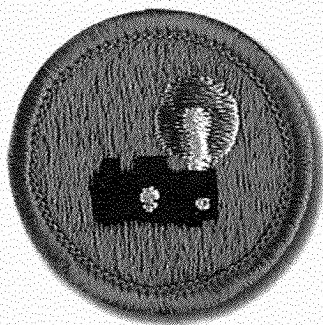

"Enhancing our youths' competitive edge through merit badges"



BOY SCOUTS OF AMERICA®

Requirements

1. Safety. Do the following:
 - a. Explain to your counselor the most likely hazards you may encounter while working with photography and what you should do to anticipate, mitigate, prevent, and respond to these hazards. Explain how you would prepare for exposure to environmental situations such as weather, sun, and water.
 - b. Show your counselor your current, up-to-date Cyber Chip.
2. Explain how the following elements and terms can affect the quality of a picture:
 - a. Light—natural light (ambient/existing), low light (such as at night), and artificial light (such as from a flash)
 - b. Exposure—aperture (f-stops), shutter speed, ISO
 - c. Depth of field
 - d. Composition—rule of thirds, leading lines, framing, depth
 - e. Angle of view
 - f. Stop action and blur motion
 - g. Decisive moment (action or expression captured by the photographer)
3. Explain the basic parts and operation of a camera. Explain how an exposure is made when you take a picture.
4. Do TWO of the following, then share your work with your counselor.
 - a. Photograph one subject from two different angles or perspectives.
 - b. Photograph one subject from two different light sources—artificial and natural.
 - c. Photograph one subject with two different depths of field.
 - d. Photograph one subject with two different compositional techniques.

5. Photograph THREE of the following, then share your work with your counselor.
 - a. Close-up of a person
 - b. Two to three people interacting
 - c. Action shot
 - d. Animal shot
 - e. Nature shot
 - f. Picture of a person—candid, posed, or camera aware
6. Describe how software allows you to enhance your photograph after it is taken. Select a photo you have taken, then do ONE of the following, and share what you have done with your counselor.
 - a. Crop your photograph.
 - b. Adjust the exposure or make a color correction.
 - c. Show another way you could improve your picture for impact.
7. Using images other than those created for requirements 4, 5, and 6, produce a visual story to document an event to photograph OR choose a topic that interests you to photograph. Do the following:
 - a. Plan the images you need to photograph for your photo story.
 - b. Share your plan with your counselor, and get your counselor's input and approval before you proceed.
 - c. Select eight to 12 images that best tell your story. Arrange your images in order and mount the prints on a poster board, OR create an electronic presentation. Share your visual story with your counselor.
8. Identify three career opportunities in photography. Pick one and explain to your counselor how to prepare for such a career. Discuss what education and training are required, and why this profession might interest you.

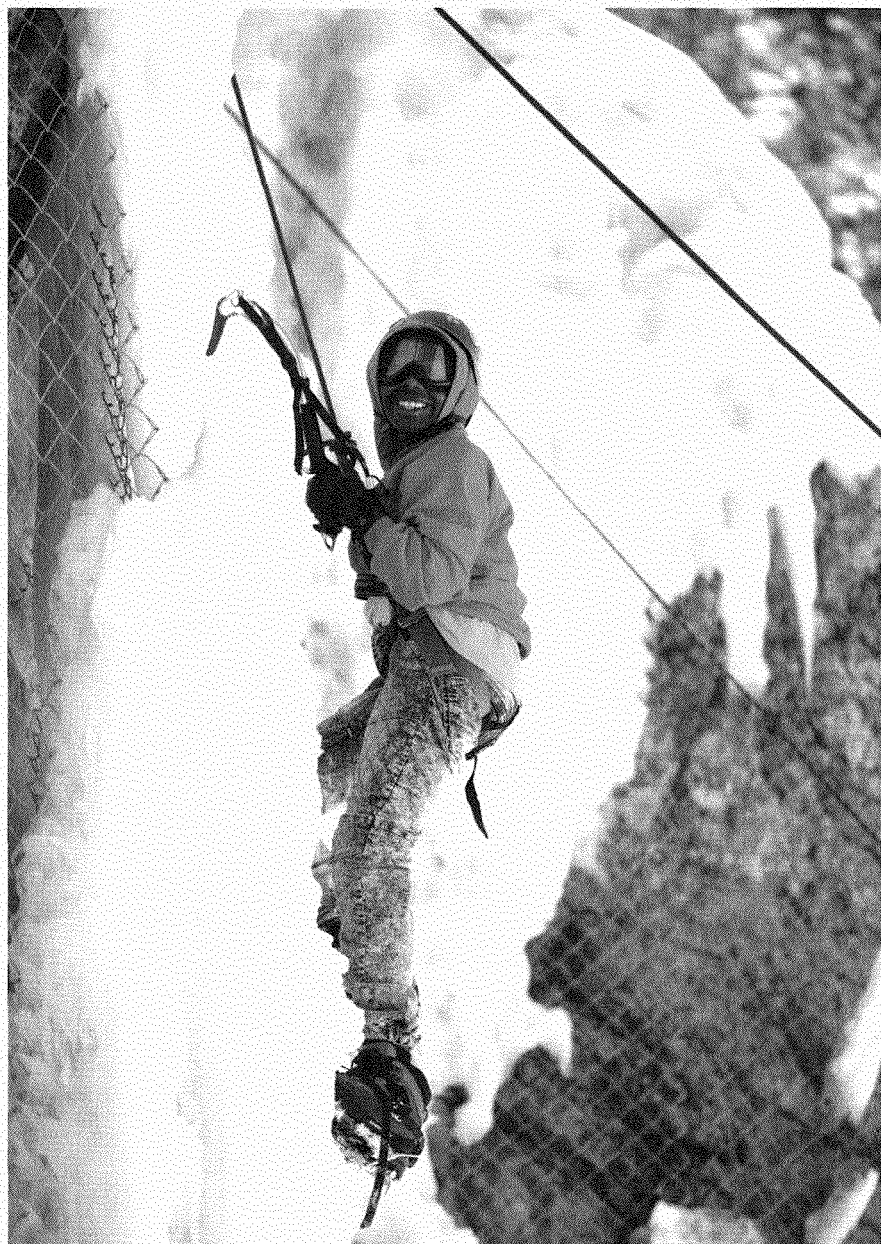

Contents

Introduction	7
What Makes a Good Photograph?.....	13
Cameras and How They Work	35
Image Adjustment: Making the Photos You Take Even Better	41
Telling a Story With Your Pictures	49
The Ethics of Photography	59
A Career in Photography	63
Glossary	67
Photography Resources	73





Introduction

Photography is a part of everybody's life. You look at photographs all the time. Your school textbooks, the local newspaper, the internet, and your Scouts BSA handbook all have photos. You might see photos hanging on the walls around you at home, at school, and in a museum or gallery, and on your troop website.

Beyond capturing family memories, photography offers a chance to be creative. Many photographers use photography to express their creativity, using lighting, **composition**, **depth**, color, and content to make their photographs into more than snapshots. Good photographs tell us about a person, a news event, a product, a place, a scientific breakthrough, an endangered animal, or a time in history. Imagine what the world would be like without photography.

Words shown in **bold print** appear in the glossary near the back of this pamphlet.



Your parents probably took photographs of you soon after you were born or on your first birthday. Photos provide lasting memories of family milestones, Scouting activities, vacations, holidays, and other special events.

Choosing subjects and taking photos can be exciting. What's even more fun is sharing images with your friends. This pamphlet will help lead you into the fun of photography. Using this information and fulfilling the requirements for the Photography merit badge will put you on your way to capturing the visual world. You will find that creating thoughtful photographs can be much more rewarding than just shooting snapshots.

The History of Photography

Photographic technology, compared to the whole of human history, has developed in only the blink of an eye. Less than two centuries ago, in 1839, French artist Louis-Jacques-Mandé

Daguerre created a process called the **daguerreotype**, which produced a **sharp** and detailed image but could not be printed.

Samuel F.B. Morse, who was an American painter and inventor, met Daguerre in Paris. Upon returning to New York, Morse set up a studio and began to make daguerreotypes. He also taught the new process. One of his students was Mathew Brady, whose crew of photographers made documentary photographs of the Civil War. Brady wrote to Morse in 1855, acknowledging his teacher as "the first successful introducer of this rare art in America."

Daguerreotype of Louis-Jacques-Mandé Daguerre

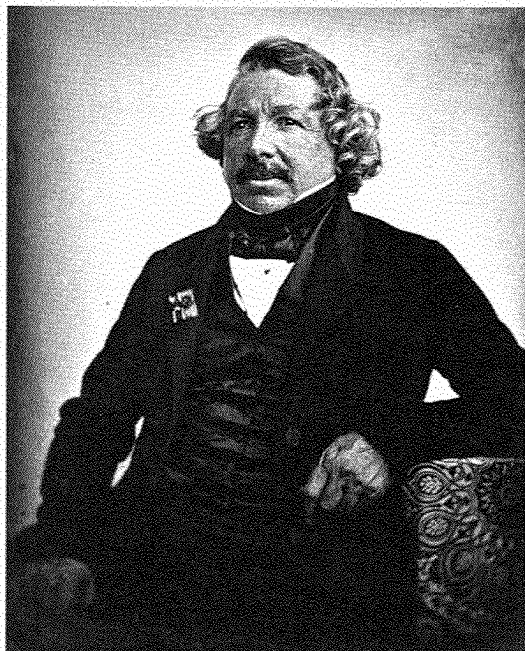

In 1841 Henry Fox Talbot introduced the calotype, the first negative/positive system of photography. The negative was paper and less detailed than the daguerreotype, but copies could be made.

The next advancement, in 1851, was the collodion wet plate, a light-sensitive emulsion coated on glass. The plate was made in the field, exposed, and developed before it was dry. This produced a high-definition glass plate negative from which many **prints** could be made.

In 1880 American entrepreneur George Eastman patented a process to make dry plates, which did not have to be processed in the field. By the end of that decade, Eastman had also patented the first photographic **film**, coated on one side with a gelatin emulsion containing microscopic, light-sensitive silver halide crystals. Eastman's flexible film base also led to the invention of motion picture cameras in the early 1890s, and film remained the standard medium for photography throughout the next 100 years.

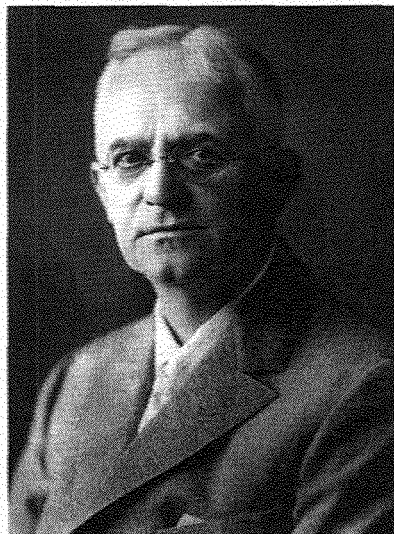
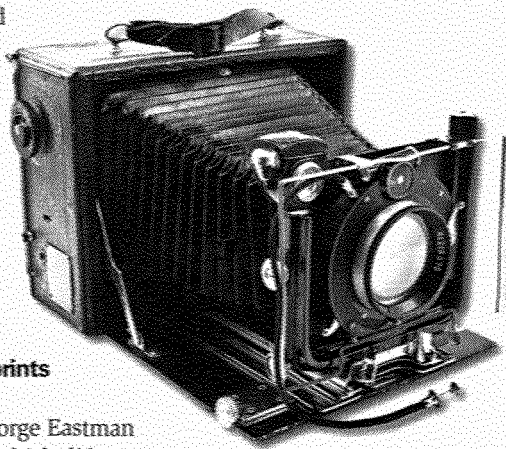

George Eastman, an inventor, entrepreneur, and philanthropist, was largely responsible for making photography available to the masses.

Camera Film— A Thing of the Past

While camera film may be a thing of the past, for more than a century it played a significant role in photography. You may have seen the familiar canisters typically used to store a roll of film that was loaded into a camera and allowed the user to take a specific number of photos. Film came in a variety of types including black-and-white negative, color negative, and color transparency (slide) films.

Photographers could choose from a number of different film speeds, such as 100-speed (100 ISO) film, which was used on sunny days and when a photographer needed more control over the level of artificial light (usually a flash). Film with a faster speed, such as 400 ISO, would be used with less light, such as outdoors on a cloudy day. The higher the film speed number, the more sensitive the film was to light. However, higher film speed reduced the sharpness and quality, giving the photo a grainy appearance. While higher film speed was popular with the amateur photographer, a professional photographer or more serious amateur would opt to use the slowest film speed possible for the best quality.

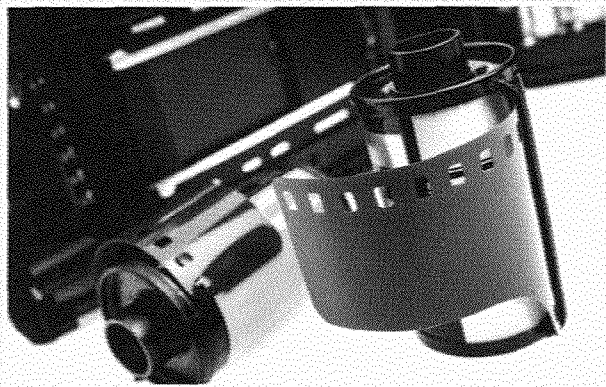

Eastman Kodak created the first digital camera in 1975. The camera weighed 8 pounds and recorded black-and-white images to a cassette tape. But this prototype was not developed for production, and it wasn't until the early 1990s that true digital cameras were introduced in the marketplace. Since then, **image sensors** have replaced roll film as the industry standard, storing pictures that can be downloaded from the camera to a computer or posted directly to social media.

Perhaps the greatest advantage of digital photography over the wet chemistry and film methods of the past is the ability to immediately learn from the picture you just made. You know instantly whether your picture is satisfactory or you need to make adjustments.

Among Samuel Morse's many inventions were the telegraph and its language of transmitting messages—Morse code. The code uses dots and dashes via sound (whistle, horn), light flashes (flashlight, lantern), or electrical pulse to communicate. The requirements for the Signaling merit badge, one of the original 57 merit badges available in 1911, included sending messages in Morse code. You can learn more about Morse code by earning the Signs, Signals, and Codes merit badge.

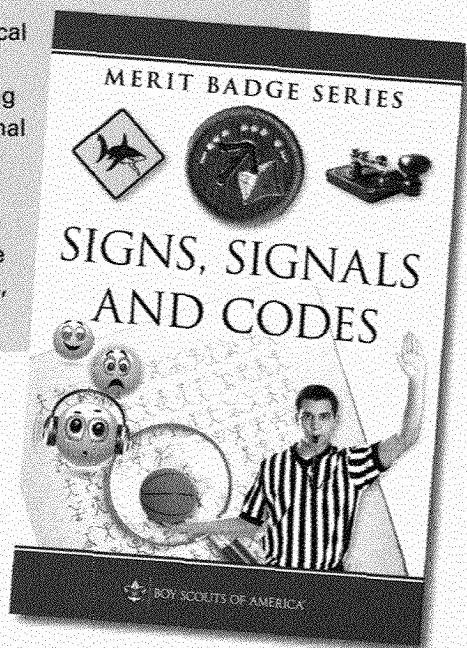



What Makes a Good Photograph?

Photography requires not only creativity but also technical ability. The guidelines in this section will help build a good understanding for making interesting, properly exposed, and well-composed photographs.

Light

The human eye sees certain wavelengths of light. What people can see is known as the visible spectrum of light. Beyond this range are wavelengths that our eyes can't see—infrared, ultraviolet, X-rays, and others.

Photographers work with just two types of light: natural and artificial.

Natural light, provided by the sun, moon, or stars, is available outdoors, as well as indoors as it passes through windows and illuminates a room and its contents. All other light—including streetlights, household lamps, car headlights, or the **flash** on your camera—is considered artificial light.



Natural light can give off certain casts of color. Early morning and late afternoon sunlight produces warmer, more amber colors. The low direction of this light and its warmth make it the preferred light among many photographers. The shadows are longer and the light softer at this time of day. During the middle of the day, the sun produces harsh shadows and cooler, bluish colors.

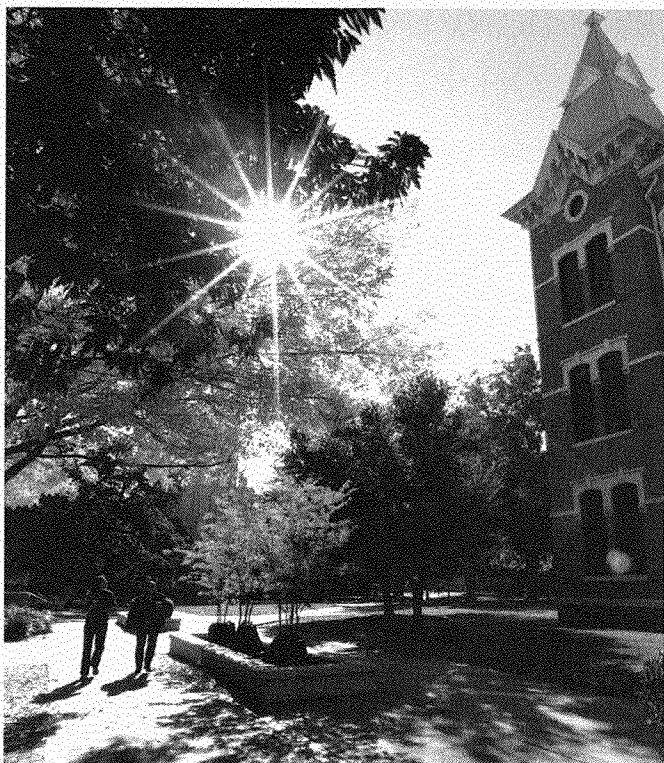

Incandescent light such as from a table lamp produces a warm cast, creating a mood similar to a campfire's glow. Fluorescent light inside an office building casts a greenish light. Your eyes correct for this color. You can use this light to enhance your desired effect, or you can correct the color by using a flash or attaching a correcting **filter** to your **lens**. Digital cameras can adjust for different colors of light by adjusting white balance. Most digital cameras can be set for **automatic white balance (AWB)** or you can select the desired white balance on your own.

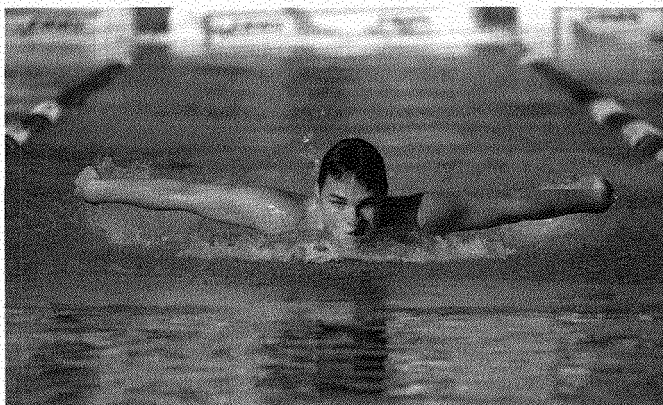

Daylight image:
This photograph was taken in bright daylight and shot with the white balance set to auto.

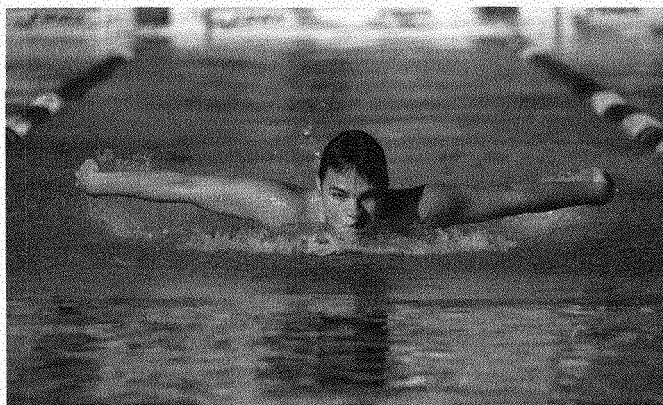

Shade image:
This photograph was taken in bright daylight and shot with the white balance set to shade. Notice that the image is too yellow.

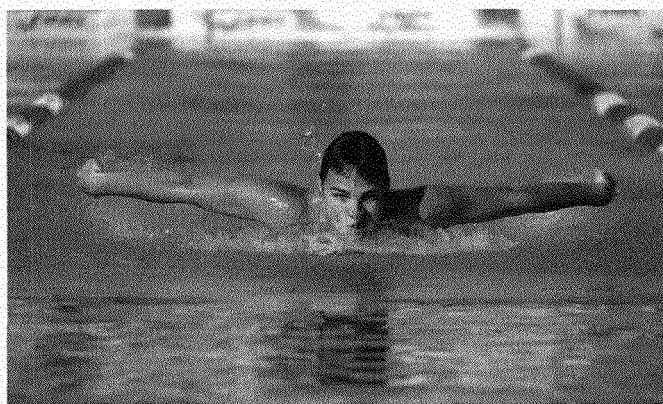

Tungsten image:
This photograph was taken in bright daylight and shot with the white balance set to tungsten. Notice that this image is too blue.



Flash

A flash is an artificial light source that adds light to the **ambient (existing) light**. It can be a flash built into your camera or attached to your camera or on a stand with a reflective umbrella like you see in a portrait studio. Most modern flash units can automatically adjust the output of light. With an adjustable flash, you can control the amount of light on your subject.

Flash also is used to stop action. Used up close, the flash freezes movement for that split second. If you are too far away from a subject, your flash may be too weak to illuminate or stop action. Check the scale on your flash to know its range. The LCD display on most modern flashes will show the flash range based on the other camera settings. A camera with a built-in flash will illuminate a subject only 10 to 20 feet away. An automatic flash reads the light reflected off the subject to determine the range of flash.

Be sure your flash is reading the light off the correct subject; if there is anything between the flash and the subject, the flash might read that reflecting light and inadequately light the real subject. The flash will act differently depending on what the subject is made of. As an example, a street sign that is made to reflect light will cause the flash to not put out enough light for the intended subject.

Exposure

Three camera settings contribute to the **exposure**, which is the amount of light that reaches the electronic image sensor. These settings are shutter speed, **aperture**, and **ISO**. They are all interrelated.

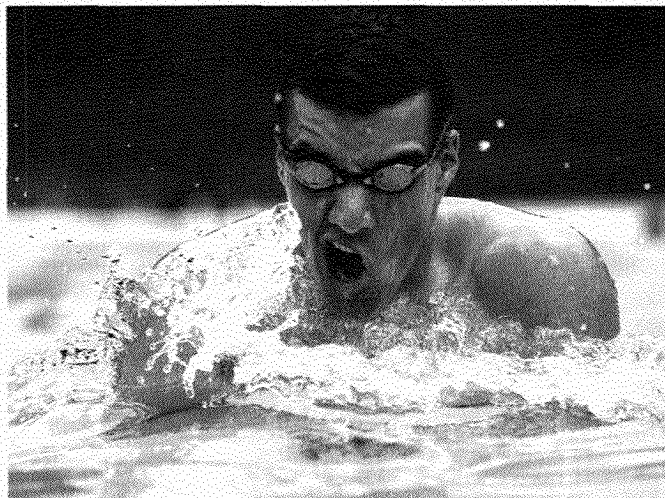

For any given lighting situation, there is only one correct exposure. As an example, when using 100 ISO your exposure is 1/125th of a second at f/16 on a sunny day. This is known as the “sunny 16” rule.

Shutter Speed

Shutter speed controls the *length of time* the **shutter** is open to let light into a camera. For example, 1/125th of a second is twice as fast as 1/60, and 1/250 is twice as fast as 1/125. Moving the other way, the slower the shutter speed, the longer the light will pass through the lens.

Aperture

The aperture of a camera lens works just like the iris in your eye. It opens or closes to adjust the amount of light reaching the **sensor**, just as the iris in your eye adjusts to bright or dim environments. Adjusting the aperture, or **f-stop**, in one direction or the other cuts in half or doubles the *amount* of light passing through the lens.

By shifting the f-stop you are shifting the size of the opening in the lens: The lower the f-stop number, the more light you are letting in. For example, an aperture of $f/5.6$ will allow twice as much light through the lens as the $f/8$ setting. To let in half as much light as the $f/8$, change the f-stop to $f/11$.

$f/16$ $f/11$ $f/8$ $f/5.6$ $f/4$ $f/2.8$

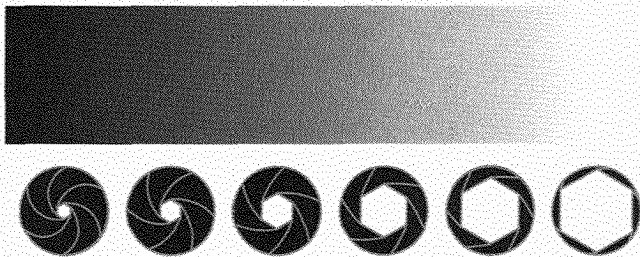

Aperture openings and f-stops

Common f-stop numbers are $f/1.2$, $f/1.4$, $f/2$, $f/2.8$, $f/4$, $f/5.6$, $f/8$, $f/11$, $f/16$, $f/22$, and $f/32$. The f-number is calculated by dividing the focal length of the lens by the aperture (lens opening) you are using.

The f-number results from dividing the focal length of the lens in millimeters by the size of the opening as the aperture is adjusted. The lens is marked by its maximum aperture or widest opening possible. For example, a 100mm lens with a maximum opening of 25mm is an $f/4$ lens ($100\text{mm lens} \div 25\text{mm maximum opening} = f/4$). Smaller openings divided into the same focal length lens produce larger numbers ($100\text{mm lens} \div 12.5\text{mm opening} = f/8$). You can easily see from this formula how larger f-stop numbers actually represent smaller openings in the lens.

Depth of field is the range of distance between the nearest and the farthest objects that appear in acceptably sharp focus. The aperture that you use will affect depth of field. The smaller the f-stop— $f/22$, for example—the greater the area that will be in **focus** from **foreground** to **background**. A larger f-stop— $f/2$, for instance—creates less depth of field. That is, the part of the image in sharp focus will be more limited. Distance to the subject will also affect depth of field. As an example, if you use the same lens and aperture setting but move closer, the depth of field will be shallower.

A smaller f-stop, *top*, results in a greater area in focus from foreground to background. A larger f-stop, *bottom*, results in an image with less area sharply in focus.

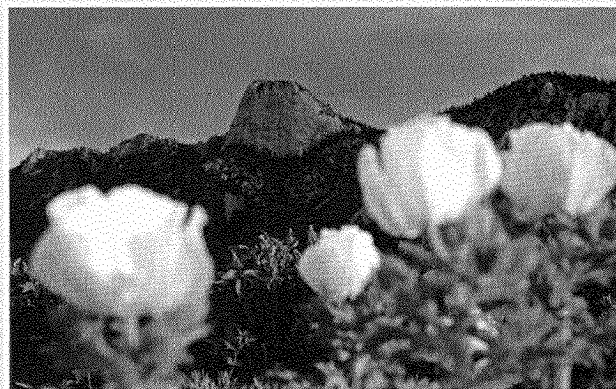

ISO

ISO is simply an acronym for the International Standards Organization. This organization sets the standard by which camera sensors and their sensitivity to light are measured. By changing the ISO setting, you control the relative sensitivity of the electronics in your camera to light. With every doubling of the number, the camera's digital sensor becomes twice as sensitive to the light available for the picture. So a setting of 400 has twice the sensitivity of 200, and a setting of 800 is twice as sensitive as 400, etc.



All three settings—shutter speed, aperture, and ISO—work together to achieve proper exposure. Suppose your camera is set to 1/125th of a second, f/8, and ISO 400. But you want to photograph action and you know you will need a higher shutter speed, so you decide to use 1/500. Changing your aperture increment in the opposite direction—from f/8 to f/4—and keeping the ISO where it is will maintain the same exposure. Your camera is now set at 1/500, f/4, and ISO 400. For an equivalent exposure you could use 1/500, f/5.6, and ISO 800. Can you see why?

Variations in shutter speed and aperture can be used for the kind of picture you are trying to achieve. Faster shutter speeds freeze motion; slower shutter speeds create blur. A stopped down aperture (higher f-number) creates an extended depth of field or zone of acceptable sharpness. A more wide-open aperture (lower f-number) has limited depth of field, such that background is blurred and the focused object is sharp.

ISO enables you to use the particular shutter speed or aperture you want for creative effect. For example, suppose your camera is set at 1/500, f/2.8 (the widest possible aperture), and ISO 400. You are afraid that 1/500th of a second will not be fast enough to stop action so you want to use 1/1,000. You cannot open your aperture any more to compensate for the higher shutter speed, but you *can* raise the ISO from 400 to 800 to compensate.

When starting out, you can make good pictures using the automatic settings on your camera. As you practice and your knowledge of photography grows, you will be able to enhance your work by understanding and using creatively the magical interaction of shutter speed, aperture, and ISO.

Measuring Light

The key to determining proper exposure is to accurately measure the lighting. Most **single-lens reflex (SLR) cameras** have built-in **light meters** that measure the light reflecting off the subject. A camera with manual mode allows you to choose both the aperture and the shutter speed as you take a light reading.

Many professional photographers and serious amateurs prefer using manual control to automatic. With manual exposure controls, you can determine the shutter speed needed to stop movement or the aperture required to get only the foreground in focus and not the background.

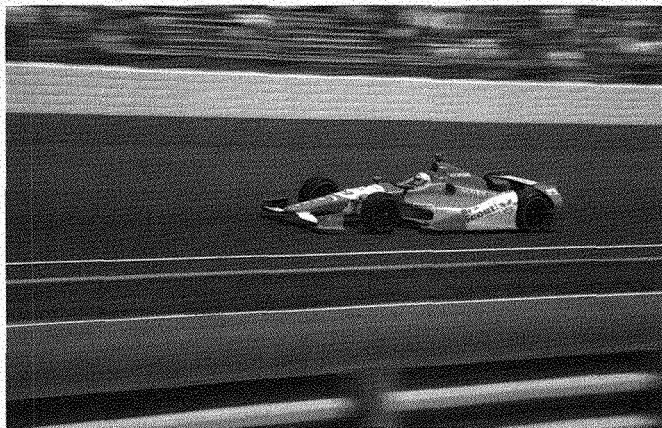

The manual for your camera details how it works. Carry it with you in your camera bag.

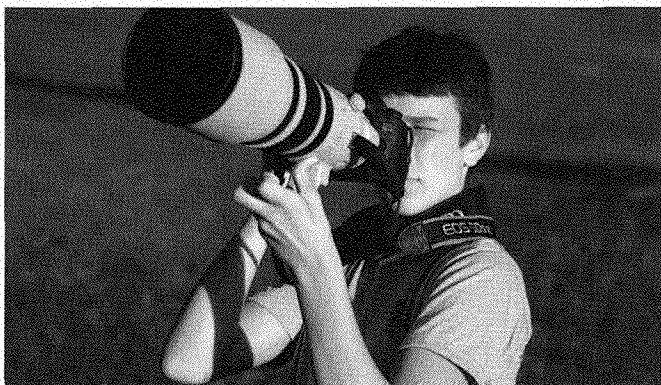

With a fully automatic setting, the camera automatically sets both the shutter speed and the aperture. In automatic point-and-shoot cameras, your shutter speed and aperture are selected for you and usually make for good exposure.

Low Light

In settings where available light is limited, the camera should be set at a high enough ISO to enable a shutter speed that would prevent unwanted motion. For example, if the initial exposure is 1/30th of a second at an aperture of f/2.8 and an ISO setting of 200, increasing the ISO to 1,600 allows a shutter speed of 1/250th of a second, which is more than enough to prevent a blurry picture caused by the photographer's motion.

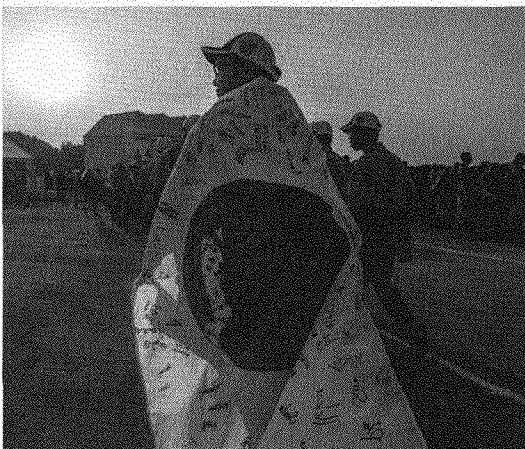

Shooting in sunlight or other brightly lit conditions might require a shutter speed and f-stop combination that is beyond the capability of your camera; in such cases, a lower ISO setting is best.

There is a negative aspect of using high ISO settings, particularly with point-and-shoot cameras with small image sensors. In general, the higher the ISO, the higher the electronic **noise** in your image.

Noise can take several forms. It can appear as color flakes in areas of the picture that should be neutral in tone; these flakes typically have a pattern to them. Sometimes the noise is random or it looks like bands of tonal variation in the picture. A common term for this noise is "grain."

The electronics in modern digital cameras are very sophisticated computers. Many cameras have the ability to reduce noise at higher ISOs as the picture is processed inside the camera. There are a number of **image adjustment** software applications that can reduce noise in a photograph. Software from camera manufacturers including Canon, Nikon, and Sony are tuned to optimally reduce noise in pictures made from their cameras.

If you plan to shoot in low-light settings like campfires, you will probably be using slow shutter speeds with the lens wide open (maximum aperture) even with a high ISO setting. This increases the risk that the shot will be blurry, so make sure you provide stable support for your camera. A tripod is perfectly stable but would not normally be carried on a hiking trip, though it might be available at large gatherings such as camporees.

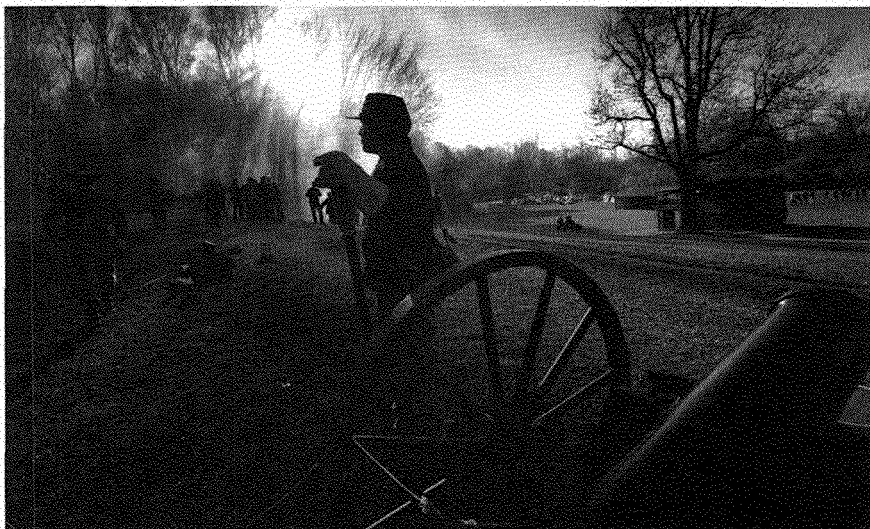

Some commercially available hiking sticks have a camera-mounting bolt in the top of the handle. When attached to a camera, the hiking stick becomes what photographers call a monopod. This support will hold the camera much steadier than you could hold it with your hand. If necessary, look for a natural object like a boulder or stack of wood to serve as a stable base for your camera. Bracing the camera against a tree will work too.

Try to avoid using a flash when taking photos at a campfire or other settings where a relatively subdued mood is appropriate. Using higher ISOs and bracing the camera can result in sharp, spectacular pictures in low light without distracting and annoying your fellow participants. If possible, test the different options ahead of time to see what works best.

Most cameras today let you use something between a completely manual setting and a fully automatic setting. Selecting “shutter priority” mode lets the photographer choose the shutter speed desired while the camera automatically sets the aperture. “Aperture priority” mode lets the photographer choose the aperture while the camera sets the correct shutter speed. Some consumer-priced digital cameras are fully automatic, whereas higher-end and professional models allow for manual control. Most phones that have cameras can shoot only fully automatic unless a particular app allows the adjustments.



Composition

Good composition in photography is much like that in other visual arts. Photographic composition involves such elements as framing, **contrast**, texture, leading lines, balance, and the rule of thirds. Here are a few guidelines for good composition.



Rule of Thirds

As you compose your subject in the viewfinder, think about the placement. Placing your subject off-centered both vertically and horizontally is a starting point.

Use the rule of thirds to help understand this concept. On a blank, rectangular sheet of paper, draw two lines dividing the paper into three equal parts top to bottom, then two more lines dividing it into three equal parts side to side. You should have nine small sections with four intersecting lines. Imagine these lines in your viewfinder when taking pictures. Place your subject at or near one of the four spots where the lines intersect to help avoid a centered, bull's-eye effect. If your photograph has something like a horizon in it, place it on one of the two horizontal lines.

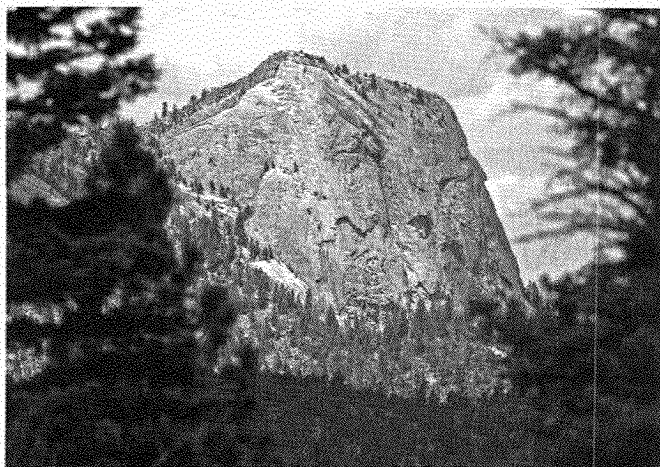

Framing

Framing means almost surrounding your subject with some nearby foreground element, such as overhanging tree branches. This technique draws attention to the center of interest in the image. The contrast between the near objects and the distant subject also can help show distance. Framing can be helpful for disguising a dull, boring sky or hiding unwanted scene elements.

A photographer may soften the contrast in a photo by using fill light. For example, there may be a source of illumination that lightens shadows cast by the main light and thereby reduces the contrast in a photograph.

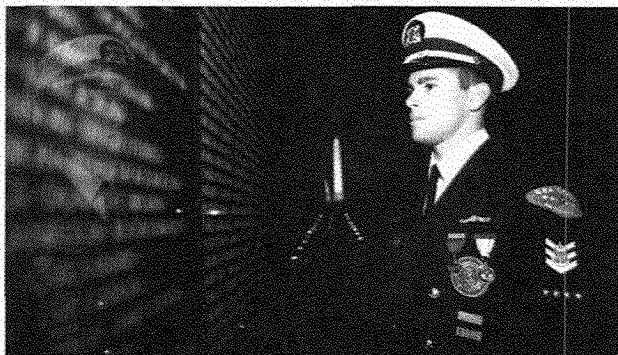

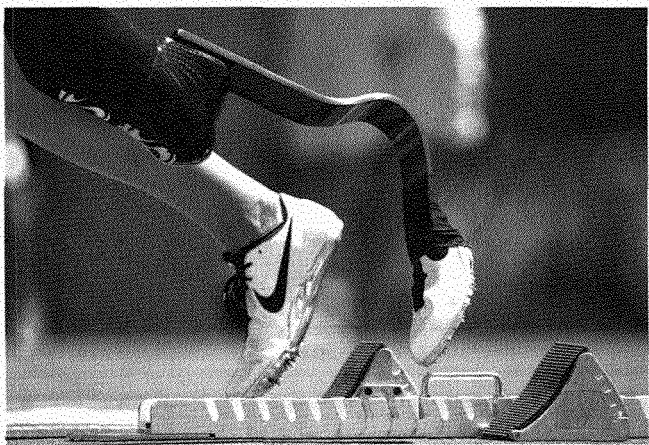



Contrast

Contrast adds interest by emphasizing differences in the elements that make up an image. Differences in tone, color, texture, size, or shape, for instance, can create appealing contrasts in a photograph. In this example, the hikers' light-colored hats and the leaves in the upper left corner contrast well with the darker tones elsewhere.

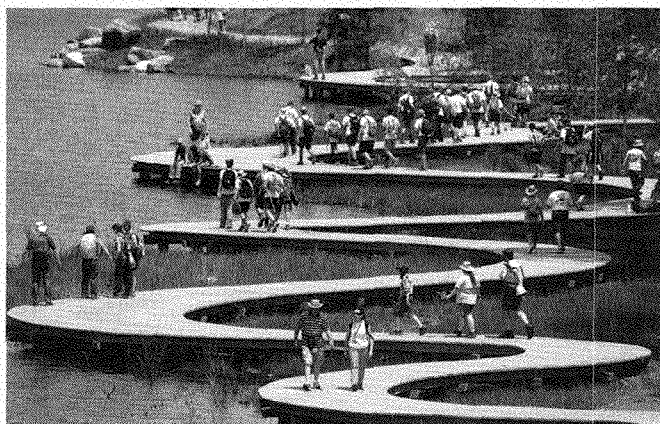

Leading Lines

Leading lines, straight or curved, lead the viewer's eye into the picture and draw attention to the subject. You can find a line in almost anything—a road, fence, bridge, stream, or hedge, for example. Even a line of people waiting to buy movie tickets can be used effectively.



Balance

Balance refers to the weight or significance of objects in the picture and how they work with other portions of the image. Symmetrical balance divides the picture into even halves. A photograph with asymmetrical balance has two very different halves.

Backgrounds

Backgrounds can add to or detract from photos. Even if the photographer does not notice something distracting, the camera will. Before you press the shutter release, look to see if there is a lamp or a pole growing out of your subject's head.

Avoid clutter. Use high or low angles to separate the subject from a busy background. You might need to add background information to a foreground subject to give your photos a feeling of depth. You can use a shallow depth of field to isolate your subject from a confusing background.

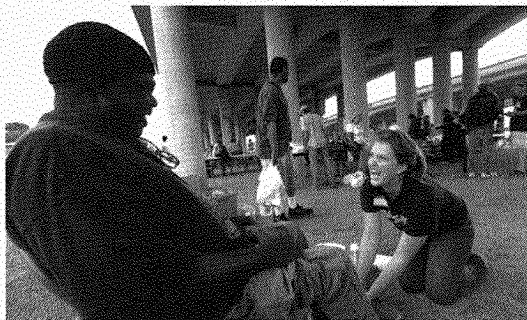

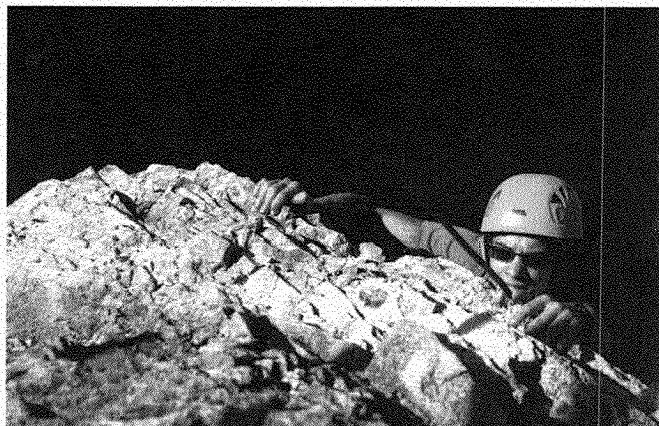

Camera Angles

A normal **camera angle**, looking straight across at your subject from its own level, usually produces the most natural—although not the most dramatic—viewpoint. Animals and children usually look their best when photographed at their own level.

Some subjects, however, are better photographed from a low or high angle. You may avoid a cluttered or ugly background by looking up at your subject, shooting from a low angle to put trees or a blue sky in the background. Many scenic pictures will appear more vast if you look down at them from a high angle.

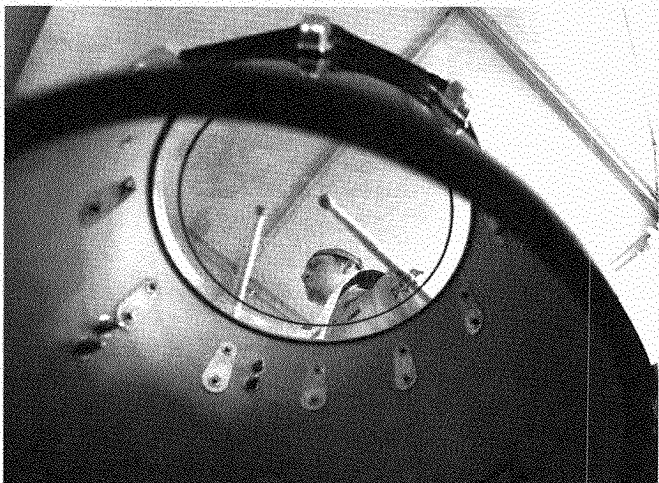

Angle of View

The angle of view is the amount of a scene that a lens can take in. The lens you use determines the angle of view. Some point-and-shoot cameras have a fixed focal length lens, giving you only one angle of view. This angle of view is much like what human eyes see in normal vision, roughly equivalent to a 50mm lens. Other cameras have zoom lenses, which give a varied focal length and varied angle of view.

Generally, a wide-angle lens will give a larger angle of view, while a telephoto lens compresses the subject and gives a smaller angle of view. A wide-angle lens is a good choice when you are close to your subject. A telephoto lens is best for subjects when you can't get up close.



Stopping Action

Earlier we discussed the importance of f-stops in controlling your depth of field and what is in focus. Now look at how the other part of the exposure equation—shutter speed—helps in stopping action.

Remember that shutter speed controls the length of time that light enters the camera through the lens and into the sensor. Most shutter speed settings of 1/60th of a second or faster are OK if you are hand-holding the camera with a **normal** or wide-angle lens.

In low-light situations, you might not be able to set your shutter speed at 1/60 or above. Anything below this will tend to show camera movement in your final results. To attempt taking photos below 1/60, keep your arms close to your body, take a deep breath, and slowly press the shutter release button.

Some cameras and lenses have image stabilization features that minimize your own motion and may allow you to hand-hold your camera at a slow shutter speed and still make a sharp picture. Image stabilization features do not freeze your subject's motion.

Shutter speeds of 1/125 or 1/250 are best for normal situations. If you want to stop fast action such as at a track meet, a pinewood derby, or a downhill ski event, you should set your shutter speed at 1/500 or above. When using these faster shutter speeds, you will need to be in a well-lit environment with a fast ISO setting of 400 or even higher.



A higher shutter speed allows you to take sharp photos even though the subjects may be moving.

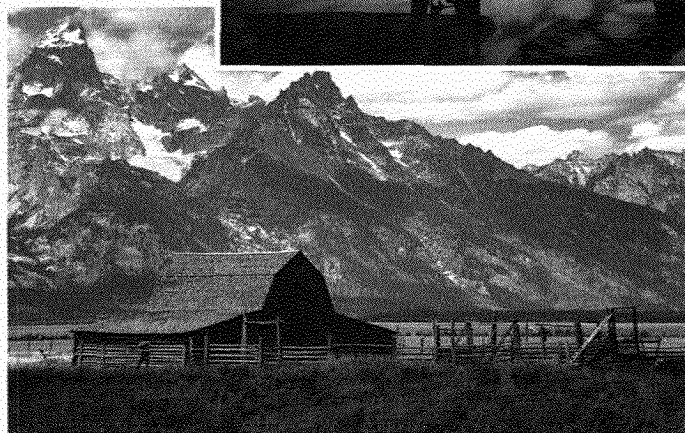
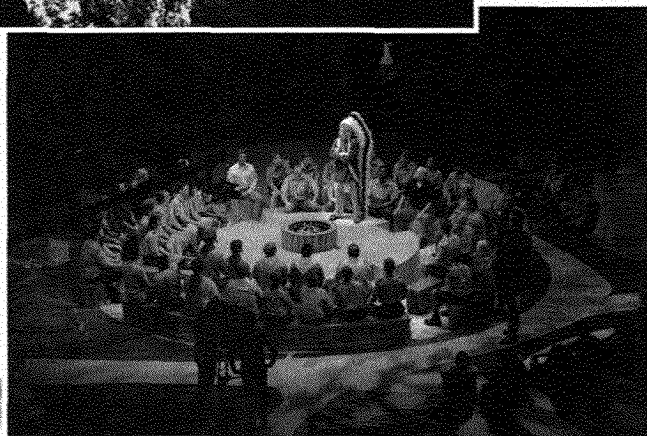
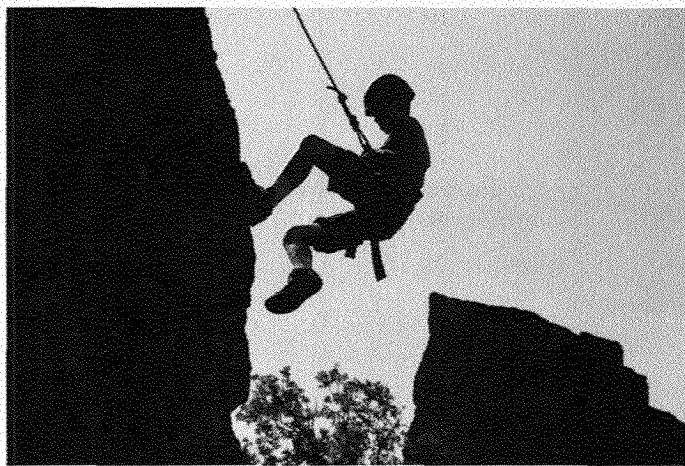

Cross section at center

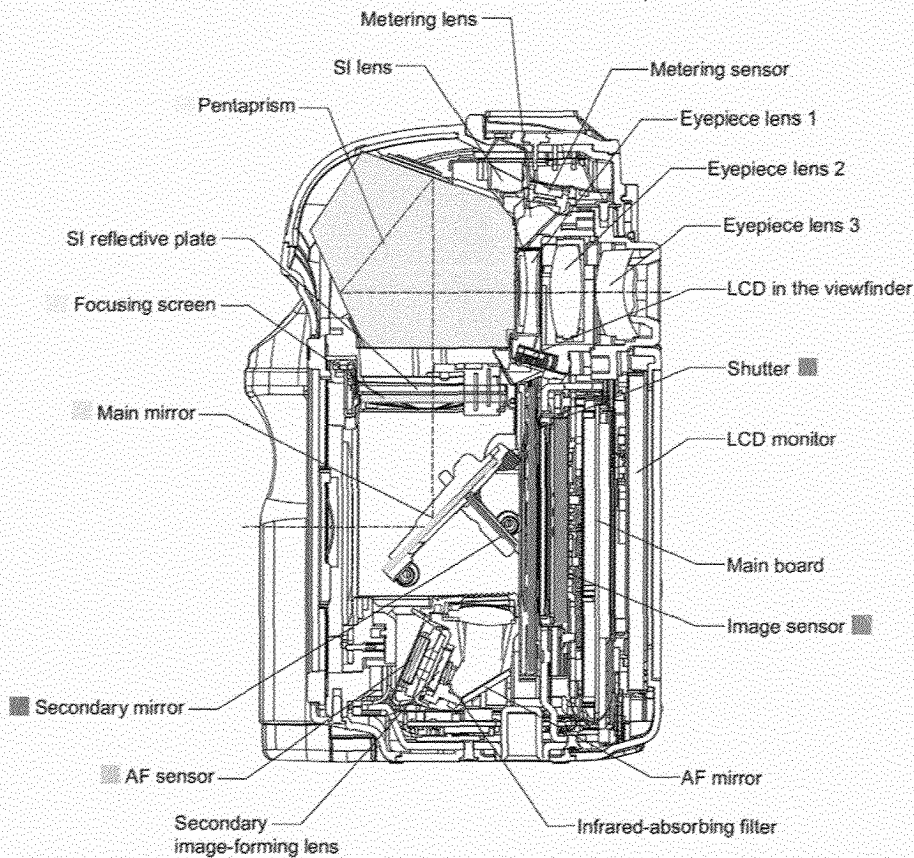

Cameras and How They Work

A digital camera is basically a light-tight box with a lens on the front and an image sensor inside. All-electronic automated cameras must have battery power.

The camera lens controls the sharpness and the angle of view. When you press the shutter release button, the camera's mechanical and electronic systems kick in. The aperture closes down to the selected f-stop and the shutter opens. Light reflects off the subject, enters through the lens, and forms an image on the sensor. The shutter then closes, blocking the light again, and the sensor is reset for the next image.

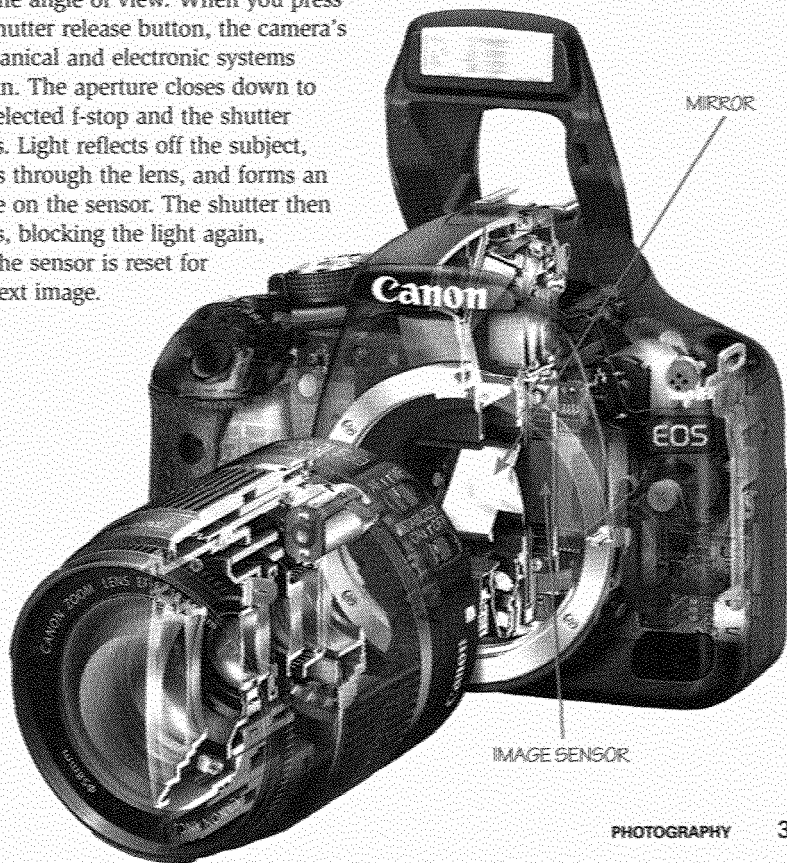

The sensor is made up of millions of light-capturing receptors called **pixels**. When light hits these spots, the number of pixels (picture elements) the camera uses determines the final quality of the image. A digital camera with 10 megapixels produces an image of higher resolution than a 5-megapixel camera. The digital files are then transferred to a computer for **editing**, viewing, and output to a printer. These digital files can be stored on the computer, on the internet, or on a storage device such as a DVD or an external hard drive.

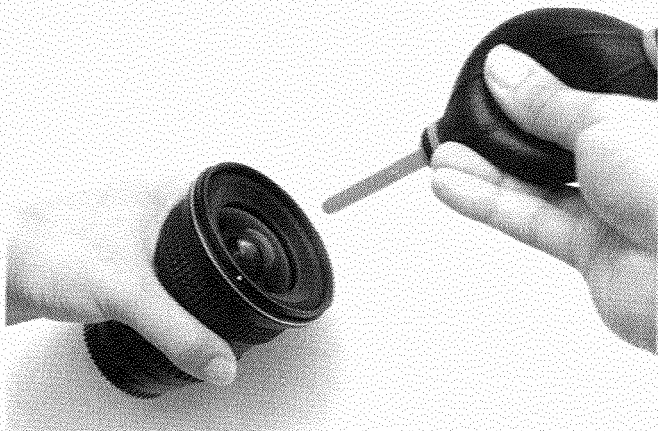

Camera and Lens Care

Whether you use an inexpensive point-and-shoot camera or a pricier SLR model, you will need to care for it. Here are some tips.

- Keep your camera dry and clean.
- Never open the camera to touch or clean the image sensor. Doing so could ruin your camera.
- Use a camera case or bag to keep and carry your camera in between uses.
- Do not leave your camera in your car or hot places for long periods.
- Avoid dropping your camera.
- When storing your camera for long periods, remove the batteries.

- Use a UV/skylight filter on the front of your lens to prevent dust from collecting and to help reduce ultraviolet rays.
- Use a camera strap when carrying your camera.
- Always secure your camera—do not leave it unattended.

Smartphone Cameras

The question is often pondered, which camera is best? The ultimate answer: the one you have with you! Increasingly, that camera is a **smartphone**.

Dedicated cameras are designed to give you an optimal photographic experience, but the quality of pictures taken with a smartphone can be extraordinarily good. The process can be totally automatic, or you can use apps that allow professional controls beyond making smartphone pictures with “auto everything.” Apps allow post-exposure image adjustment in any number of ways to achieve an enhanced photograph or wild interpretations of the scene. Some apps allow individual placement of exposure and focus. ISO can be adjusted. Some smartphones even have motion stabilization for the camera. Finally, sharing a picture with family and friends is very easy: Just press a button and the photo is on its way.



Point-and-shoot cameras that don't make phone calls are now manufactured with Wi-Fi so they can connect to smartphones. Photographs are wirelessly transferred to the smartphone and from there enhanced with various apps and moved to social media.

Every technology, of course, has its pros and cons. It takes longer to get ready to make a picture with a smartphone than with a traditional camera. Adjustments of exposure and focus are more cumbersome. Changing to a different lens, usually a clip-on addition, is also a bit complicated and sometimes involves removing a protective case from the phone.

On smartphones without mobile stabilization, tapping a button on the screen to make a picture can cause camera motion and blur the image. In those cases, an accessory is needed to mount the smartphone to a tripod for stability. All these problems are manageable if you recognize them and plan ahead.



Wearable Cameras

Since 2007, there has also been a proliferation of small, wearable cameras that are generally used to document outdoor adventures. Wearable cameras have no noticeable weight and can be easily mounted on a safety helmet or on outdoor equipment like surfboards or mountain bikes. These are sometimes called point-of-view (POV) cameras because the recorded images place viewers in the scene as if they are seeing through the eyes of the photographer.



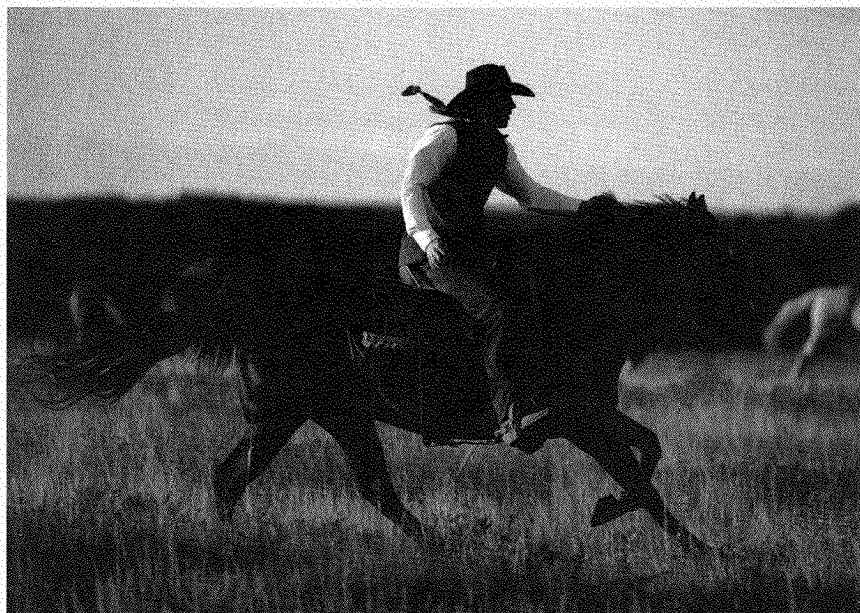

The top image is too dark. The photo above has been adjusted.

Image Adjustment: Making the Photos You Take Even Better

Photographs usually look very good when taken with modern digital cameras or smartphones. Can they be improved? The answer is almost always. A little tweaking after the image is made can make a good picture great.

Photographers call the process of improving a picture after it is made "toning." The range of tones from highlights to shadows can be adjusted as well as the overall color balance. Local areas of the picture can be lightened or darkened. The overall look of the picture can change by adjusting contrast.

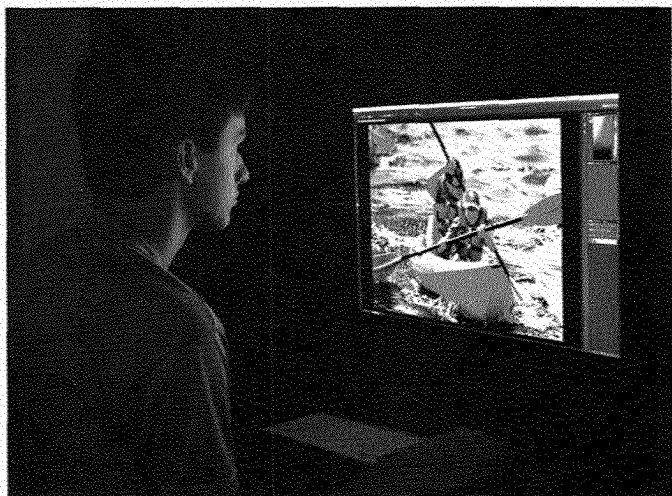

Software sometimes has an “auto” or “enhance” adjustment button that you might try. It often works well and, if it does, that is one step toward a better-looking photograph.

Tonal Range

As you take a picture, you will notice the difference in light intensity between highlights and shadows; this is called **tonal range**. Suppose the subjects in your photo are two Scouts, one wearing a white neckerchief and the other wearing a black one. When you shoot the picture, the sky is overcast with no direct sun.

In this case, the difference in exposure between black and white will not be sufficient to use the full exposure range of the digital image sensor in your camera. If you expose your picture so that the white neckerchief looks white, the black one will be a dark gray—not black. If you expose the shot so that the black neckerchief looks black, the white one will look medium gray—not white. The range of light reflected off the white and black neckerchiefs is not enough to use the full range that the sensor can capture. Photographers would call the lighting in that scene “flat.” However, software can be used to improve the lighting in the captured image so that the two neckerchiefs look as they should.

Image adjustment software often displays a rectangular box with a display of the picture’s light content (data) looking much like a mountain range. This is called a histogram. You can tell the picture is properly exposed for both shadows and highlights if the ends of the data taper to the left and right corners of the box. If the data does not range across the entire box, software controls can be used to expand the data so that it does. The visual display of the picture will show you a preview of the improvement.

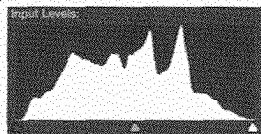

Image adjustment software offers various tools to improve a picture for impact beyond just cropping the frame or correcting the lighting and color. Explore the tools to see if you can remove imperfections such as the “red eye” effect or change the texture of the image in interesting ways.



The major camera manufacturers also distribute software for enhancement of images. Software is often the easiest path to quality images because individual camera formats are proprietary, meaning that their products and software work well together. All of these programs have “help” menus and numerous internet tutorials showing you how to use the various functions to enhance your photographs. There are also commercial programs available to help you adjust images.

Smartphone apps can make many of the same adjustments—depending on the app. Explore the features before you download an image adjustment app. Pay attention to what other photographers are using to enhance their smartphone pictures. Fortunately, most smartphone apps are inexpensive and you can experiment on a limited budget.

Color Balance

Most stand-alone digital cameras and smartphones default to automatic white balance (AWB). This setting is designed to make the colors of objects in your frame as close as possible to the actual colors—ensuring that a red apple, for example, will have the right shade of red in your picture.

Light has color, as Sir Isaac Newton discovered in 1666 when he saw colors of the visible spectrum (what humans can see) displayed as sunlight passed through a triangular prism. These are the same colors sometimes displayed as a rainbow after a rain. While there are a few other hues in the visible spectrum, the dominant three are red, green, and blue. When combined in equal proportions, these colors will create white light.



An added advantage of smartphone apps is that it is easy to move your pictures to social media. Then your family and friends can see how much fun you are having in Scouting.

The proportions of these colors vary with the light source used for photography. Candlelight produces warmer indoor images (more red) than an electronic flash, which makes the image appear cooler (more blue). The color of light varies in sunlight as well. Sunlight at sunrise and sunset contains more red than at other times of the day. Sunlight at noon has approximately equal mixtures of red, green, and blue, and pictures made in that light seem neutral in color tint—neither **warm** nor **cool**. These qualities can vary widely in daylight depending on weather conditions. If direct sunlight is blocked by an overcast sky, there is a much higher percentage of blue in the light.

The AWB camera setting is intended to remove color tints in a picture to make the lighting neutral, or without a colorcast. A white neckerchief will appear accurately as white and not tinted with blue or red.

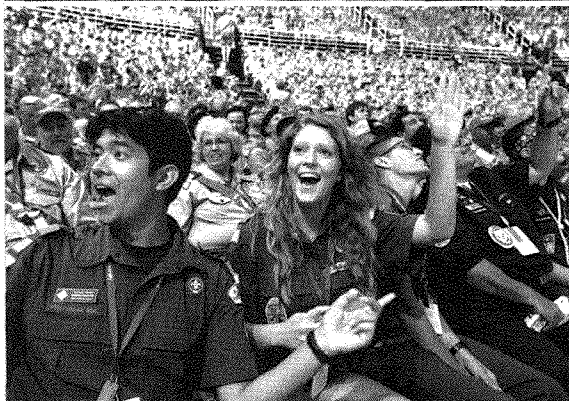
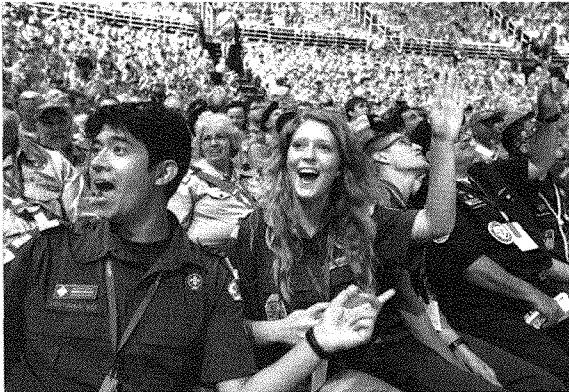

Many cameras, and some smartphone apps, allow adjustment of color balance as the picture is made. Icons are often used to display different light conditions such as sunlight, overcast sky, etc. Software can adjust the color balance after the exposure. For example, a picture made under an overcast sky may appear to have a blue tint. You can remove this tint by making an adjustment with the software to add a proportional amount of yellow. In addition, image adjustment programs often have two sliders, one to change the blue/yellow mixture and the other the green/magenta mixture. Adjusting both sliders can alter the red/cyan component in a picture.

The top photo is too yellow. A simple software adjustment makes the color appear more normal.

Red, green, and blue are the three **additive primaries of light**. Subtracting any one of those colors from white light will turn it to one of the three **subtractive primaries**: cyan, magenta, or yellow. Subtractive primaries are generally used as ink on paper to produce full-color photographs on the printed page. Subtracting red from white light produces cyan; white minus green gives you magenta; and white minus blue results in yellow light.

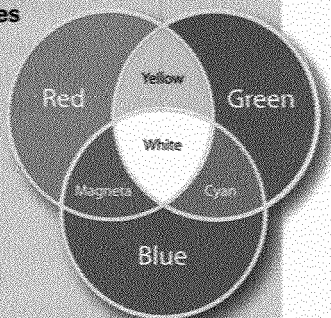

Just as any color in the visible spectrum can be created by varying the additive proportions of red, green, and blue light, so too can cyan, magenta, and yellow inks on the pages of *Boys' Life* reproduce a color photograph by subtraction. In print publications, black is added to the shadow areas in addition to cyan, magenta, and yellow inks.

Imagine you are looking at a red apple in sunlight. Remember that white light can be redefined as equal mixtures of red, green, and blue light. The pigment in the surface of the apple is absorbing green and blue light and reflecting red light to your eyes.

Now imagine you make a picture of the apple and it is reproduced in *Boys' Life* magazine. White light is falling on the magazine, which is printed using only three colors of ink: cyan, magenta, and yellow. Where the color red appears in the original photograph, the printed page will have magenta and yellow ink mixed together but no cyan.

The magenta ink absorbs green light and the yellow ink absorbs blue light. Since there is no cyan ink to absorb red light, red light is reflected to your eye from the page and you see a red apple. Black ink is added to the shadows to overcome the limits of a printing press.

In a photograph, any color may be created by addition using varying proportions of red, green, and blue light. On the printed page, any color may be created by subtraction using varying proportions of cyan, magenta, and yellow ink.

Digital camera sensors are sensitive to red, green, and blue light, and computer monitors use those three primary colors to display your picture. If you print the picture on paper, it is printed with cyan, magenta, and yellow inks.

Understanding the relationship between additive and subtractive colors is essential in color balancing your images.

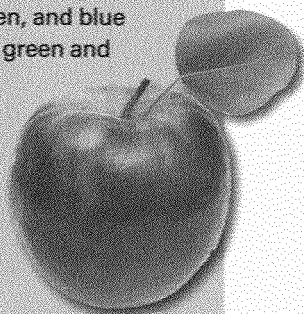

Dodging and Burning

Dodging and **burning** are terms derived from the days when photographers routinely made prints in a darkroom using chemistry. Now, in the digital era, the same words mean to make adjustments with software in specific areas of the picture that may be a little light or dark. Software controls can be used to “burn” an area that is a bit too light or to “dodge” an area that is a bit too dark. The result is a picture that seems to be balanced in overall exposure.

How will you know how much to dodge or burn? The answer is when it seems correct to your eyes. Software programs frequently use sliders to fine-tune the adjustment.

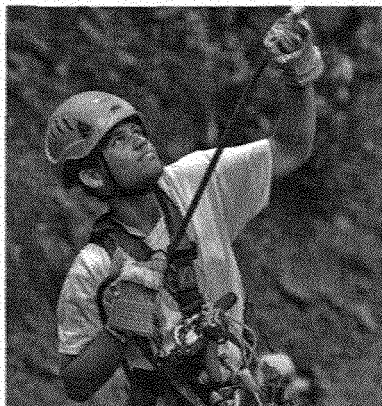

Sharpening

The same programs have tools for “sharpening” a picture. What is really happening is *edge enhancement*.

When edges are more defined and separated, the picture appears to be sharper. This assumes that the lens was focused and the shutter speed was fast enough to prevent motion blur.

Software sharpening cannot make an out-of-focus picture sharp. It's a way of making a good photograph a little better.

Cropping

Maybe you captured a great expression on your subject's face but the framing of the photo is centered so precisely that it looks too conventional. Software has a feature called **cropping** that allows you to reframe and give the picture a unique perspective. Sometimes cropping an extraneous object out of the edge of the frame gives the dominant feature more visual impact.

Cropping should be used to fine-tune a picture. If you find you are consistently cropping out a large percentage of your frame, you are not close enough to your subject when you make the pictures.

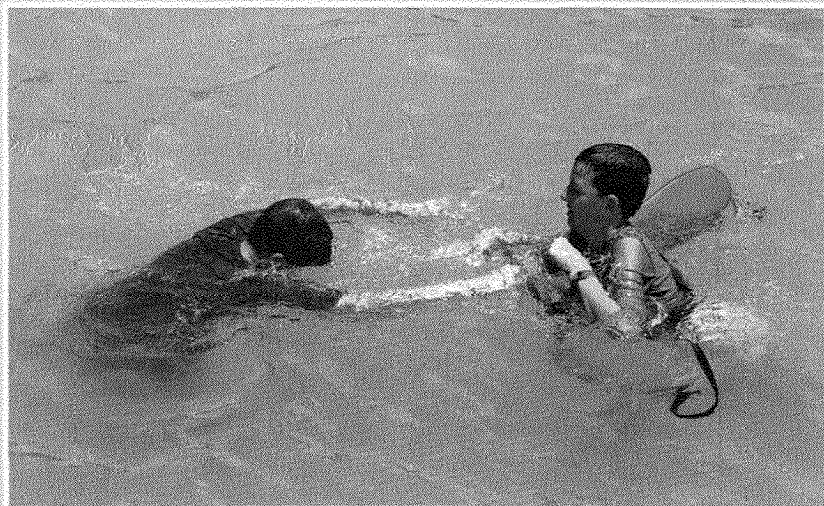



Telling a Story With Your Pictures

A picture story is much like a story you would write. It should have a beginning, middle, and end. The only difference is you use pictures to tell the story rather than words.

When you go into the field to make pictures, think about the story you want to tell. Will you tell it in a single picture or a series of pictures? What details are needed in the shots to explain what is happening? Can you write the essence of the story you want to tell in a single sentence? If not, think some more until you can state the focus of your story. This **focus statement** keeps you on track. It is the framework that provides the structure of your story.

AIR (Action, Interaction, Reaction)

Scouting is an active endeavor. Skills are learned and practiced. All that is learned is put into practice in the great outdoors, the practical laboratory of Scouting. To be a Scout is to have an active and adventurous life. So how do you capture great pictures of Scouting?

The focus statement keeps you from being sidetracked and taking unnecessary pictures.



The answer lies in three simple words: action, interaction, and reaction. In every picture you make, try to include at least one of those concepts.

Action. Scouting is loaded with action. Let your brain tell you just the right moment to press the shutter so the action will be captured perfectly. Part of taking a great action photo is anticipating what will happen next.

Let's say you are watching a two-person sawing competition in which the fastest contestant will win a piece of pie. You wait until a piece of log has just been cut through and is starting to drop to the ground. You press the shutter. This picture, you realize, is a little better than the one you made a few minutes earlier when the saw was just cutting through the wood. You anticipated and waited for the end of the log to drop—and the result was more action in the picture. Pictures are usually made in a fraction of a second. It's up to you to find the particular fraction of a second that will tell the best story.

Interaction. An older Scout is teaching a new Scout how to tie a knot. This is a great opportunity to capture interaction. Any time two or more Scouts are doing something, there is interaction. Look for it and show it in your pictures.



Reaction. Reaction in photographs is generally found in facial expressions. A Scout has just made a fire-by-friction set and is using it for the first time to try to make a fire. Success will require a magical combination of pressure on the spindle and the speed at which it spins. The Scout becomes exhausted several times without throwing a spark but, finally, achieves success. And you are there with your camera, capturing the joy in the Scout's face. The *action* is operating the bow and spindle. The *reaction* is the Scout's facial expression when he or she creates fire.

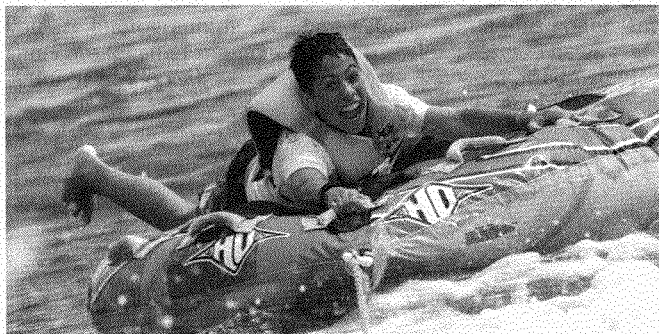

Creating Your Own Story

Illustrating an idea is different from covering an activity as it happens. When you document an event or activity, you do not set it up beforehand. For this next project, however, you will create a visual story to fit the topic or theme you have chosen.

First, come up with an idea. Talking over ideas or brainstorming with friends or family members can help you think of a topic for your project. Once you have an idea, use a technique called storyboarding—writing down on index cards or sticky notes the various photos you want to use in your project. Each card or note represents one picture, one shot, or one scene and can include a rough sketch of the shot and any pertinent information such as location, camera angle, or the message the shot should convey.

Decide how the presentation will start and how it will flow from the beginning through the middle to the end. Think about your setting and what props you might need. Decide what the subjects are to be doing in each shot. Once you have your topic all planned out and storyboarded, then set up the shots one at a time as described on your storyboard cards. Once the sequence of shots is established, start photographing.

Action.

Interaction.

Reaction.

Put some AIR in your pictures.

If a photo has one of these concepts, it's good. If it has two, it's better. If it has all three (very difficult), it's a winner.

Documenting a Story

The most common approach to visual storytelling with photos is the documentary style, using the camera to photograph what is happening—to document it, showing accurately what takes place. If this is your purpose, you should make sure that nothing in the photos is being posed or set up especially for the camera.

The more you can narrow the subject of your story, the better you will be able to tell it. For example, instead of a series of photos about Scouting in general, try focusing on a troop hike, a campfire program, or a court of honor. You might take photos of individuals or groups participating in summer camp activities or, even better, you could follow a pair of best friends on their first year at camp. Be there each day to *document* in pictures what these two buddies experience, and be careful not to interrupt or guide them. Focus on the Scouts “telling their story” in a natural way through the fun adventures they have.

Besides Scouting activities, community events may offer good visual opportunities to document. You might select a parade, a fair, a town meeting, a dedication, a competition, or any activity involving multiple participants. Find something you feel comfortable doing and ask the person in charge of the event if you can photograph it for your merit badge project. Find the right subject to give your visual story a focus. Then consider giving the story a title to help you stick to that focus.

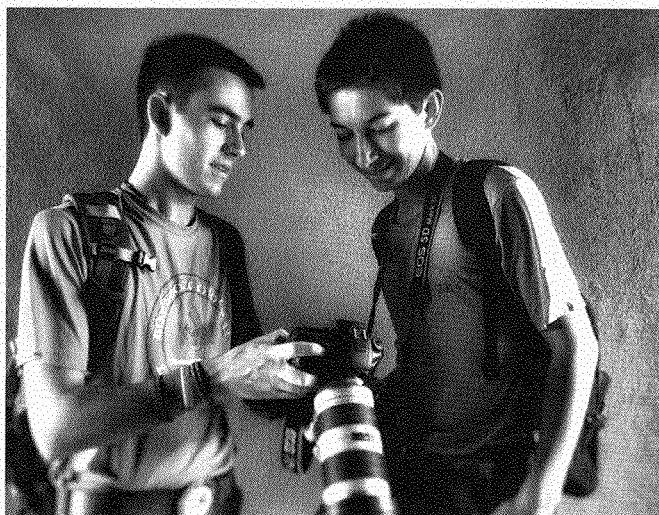

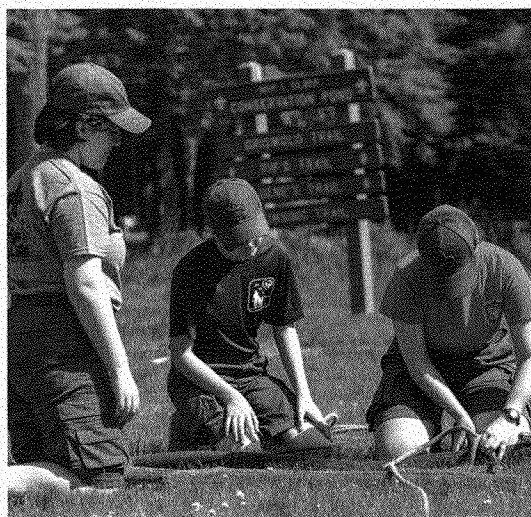

The idea of the two buddies at summer camp is a good example of story focus. The photos you shoot could provide visual information about the Scouts and the overall camp setting as they go through their daily routine there. Wherever you take your pictures, plan what to photograph by knowing the subjects' schedule and location throughout the day. Knowing there may be times when they aren't involved in anything special, look instead for interesting visual moments filled with action, interaction, and reaction (AIR).

Look for a variety of images that work together to tell the story. You will need a photo that introduces the story; this could be an overview shot that gives a sense of the location and the different people who are there. Then get shots of people interacting with each other during the event. Think about what part of the event is most important and include that special moment, or peak action. Finally, look for the closing picture. If you are in an auditorium, this could be a shot of the event coming to an end—everyone on stage for a “grand finale.” Look for an image that brings closure to the story.

Do a thorough job of documenting the event by taking multiple shots of each part of your visual story. Later, in the editing process, look for the pictures that tell the story best; then arrange them in order with a beginning, middle, and end to give the story a natural flow.



The Presentation

You may print your pictures and put them on a poster board for presentation at a troop meeting or other gathering. Or you may decide to present your story in a digital slide show. Whichever format you select is fine, but be sure to create a caption that tells the *who*, *what*, *when*, *where*, and *why* of each image. Captions supplement the photos by giving the viewer additional information.



If you create a slide show, remember to run a test to make sure that your digital format will work with the available equipment.

Now is the time to practice everything you have learned in studying for this merit badge. Practice can make you more proficient at knot tying or basic canoe strokes. You become a photographer in the same way. When you start to think of making pictures as a continuously active process where you are always thinking about the next picture—you are a photographer. Congratulations!

A Picture Is Worth a Thousand Words

You probably have heard this saying before, and it's one that photographers take to heart. They use photography to tell a story, which can sometimes be accomplished with just one picture. If there is a subject, that person may or may not be aware of the photographer. The picture might be a candid photo, where the subject is unaware of or might ignore the photographer. If it is a posed photo, the photographer directs the subject on how to sit or stand, or what to do. In a camera aware photo, the subject is looking at but not being directed by the photographer in any way. Take a shot at these different techniques and see which one you enjoy using the most.

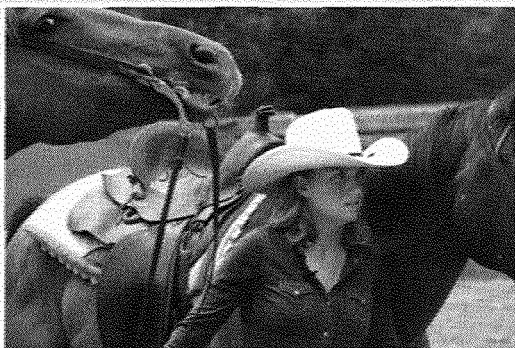

Candid



Posed

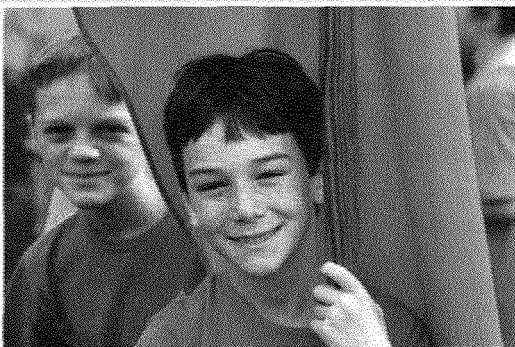

Camera aware

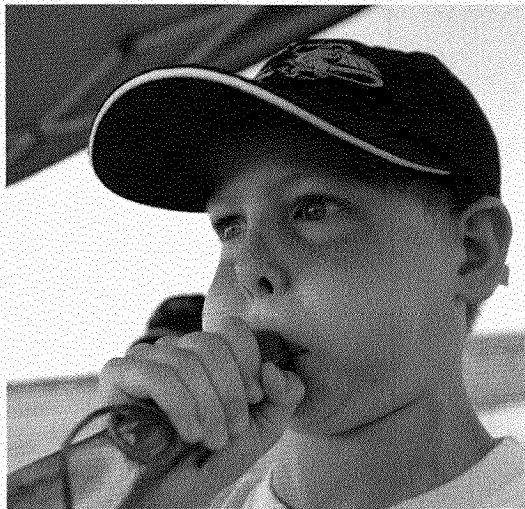

Seizing the Decisive Moment

French photographer Henri Cartier-Bresson (1908–2004) captured what he called “decisive moments” in his photography. It could be a memorable facial expression or moment in time or life that can’t be reenacted or repeated. He likened it to candid photography where a picture taken a split second before or after wouldn’t be as profound as one taken at that precise moment.

Capturing the decisive moment does not mean the photo could not be planned. In fact, Cartier-Bresson himself said it often takes patience to do so. He conceived many of his shots and took numerous photos of a scene, timed just right, so he could capture a decisive moment.

As a photographer, Henri Cartier-Bresson liked to stay in the shadows, unnoticed by those he photographed. He liked to take pictures of everyday people, everyday life, that provided plenty of opportunities for him to capture so many decisive moments.

“One must always take photographs with the greatest respect for the subject and for oneself.”—Henri Cartier-Bresson

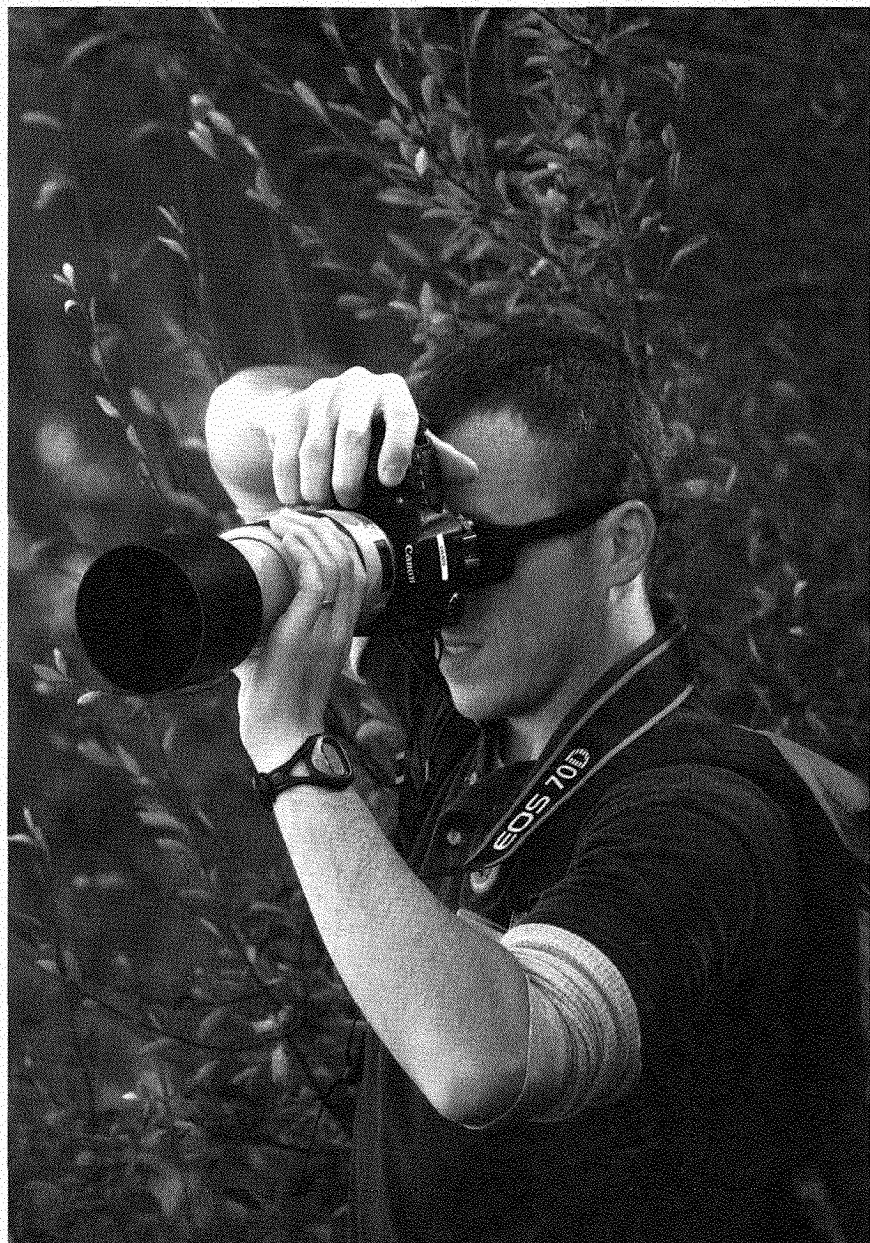

The Ethics of Photography

Photography is a way of placing viewers in a setting they might never be able to experience firsthand. Photographs in *National Geographic*, for example, take us to the ends of Earth and we learn from them even though we are not present in those physical locations. When we view such photos, we believe that what we are seeing is real; this trust is based on the reliable practice of photographers who subscribe to a professional standard of ethics.

Manipulation of photographs does occur and dates back to the late 1800s. Today, the latest software makes those tricks easier than ever before. Some enhancements may be acceptable if done in the proper context. For example, magazines often publish what are called "photo illustrations." These are highly manipulated photos intended to convey a story or an idea. Perhaps someone well known has been caught telling a lie. The photographic illustration might show the celebrity's familiar face with a Pinocchio nose. Of course, no one would interpret that image as being real, so this sort of manipulation is considered fair game. Even more commonly, photos used in advertisements have been manipulated in creative ways that may be subtle or obvious. These are images with a viewpoint!



However, the ethical standard for news, editorial, and documentary photography is that *no manipulation or enhancement* that changes what the photographer saw at the scene is acceptable. That means not removing people or objects such as telephone lines. It means not increasing saturation of colors beyond a natural level. Anything that changes the visual meaning is unacceptable because news photographs should represent reality as closely as possible.

Ethical standards apply not only to professional photographers but also to beginners and amateurs like yourself. The standards even apply when taking photos with your smartphone. Smartphones are like having a miniature camera on steroids, and many apps come with fun tools to adjust the pictures you take. You can explore your creativity by making and altering photos in weird, imaginative ways.

Remember, a picture posted on the internet is forever even if you think you deleted it. Before uploading, be sure to ask yourself if the photo is appropriate or worthy of a Scout. If the answer is no, don't post it.



But when you are telling a photographic story—such as the one required for this merit badge—you must take the documentary approach of not changing, enhancing, or manipulating the viewer's interpretation of anything you photograph. Truth is a value worth preserving when telling a story, and being *real* means being true to that story.

Finally, how do you decide when and when not to take pictures of other people? There are many ethical theories, but the simplest and best is the Golden Rule: Do unto others as you would have them do unto you. If someone took a picture of you in a particular situation and sent it out via social media, would you be OK with it? If not, don't press the shutter.

Practicing ethics is really an ordering of the values we hold, having learned them from parents, Scout leaders, religious teachers, schoolteachers, and others. Remember that a Scout is trustworthy. Thinking through ethical decisions can be a sticky process but acting ethically, in its essence, is simply doing what one ought to do.



The BSA obtains written permission, called a *model release*, from anyone appearing in a photo before the image is published in a merit badge pamphlet or other publication. The legal issues surrounding model releases are complex and vary by jurisdiction.

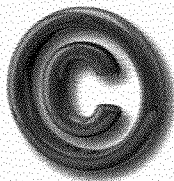

A photographer's work is copyrighted at the moment of exposure. To further protect his or her rights, a photographer may register a photograph with the U.S. Copyright Office. Those works may not be used without the copyright owner's express permission.

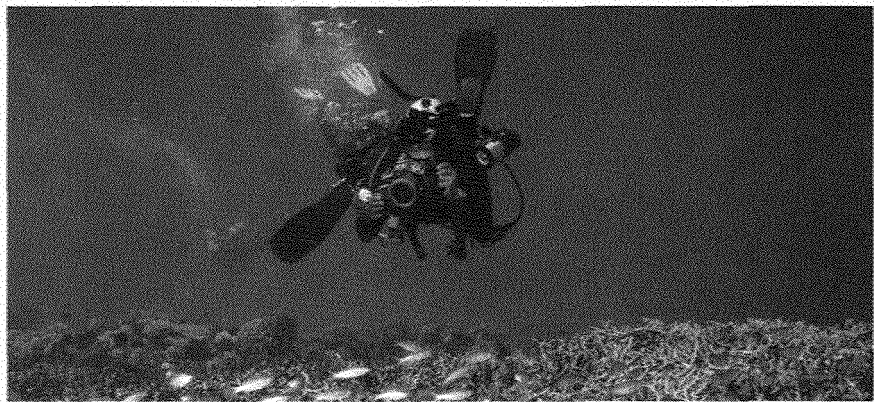

A Career in Photography

Whether you are photographing a presidential election or a class of kindergartners, photography can be fun and profitable. There are many careers in photography. Several careers are listed in this chapter, and there are many others. Many fields have photographers who work only in those particular areas, including sports, scientific, technical, educational, or research work.

The most common types of professional photography are commercial, portrait, photojournalism, and specialized work such as taking medical or underwater photos. Some careers keep you indoors in one location, while others may take you around the globe.

A digital photojournalist with a computer, for example, can receive a photo assignment in an email, go to a location, take the pictures, edit the choices, caption each image, then transmit the results to the office from anyplace around the world by using a wireless connection or telephone. This has sped up how fast news can be communicated worldwide. Before digital photography, it would take 30 to 45 minutes to get a picture on the wire. A photographer can now photograph an event like a rocket launch and have it on the internet within 10 seconds. Such assignments can keep a photographer in the field more days of the year than he or she is working in an office.

From the careers listed here, or by finding one on your own, choose a particular field of photography that interests you and research it. Talk with your counselor about what you have learned.

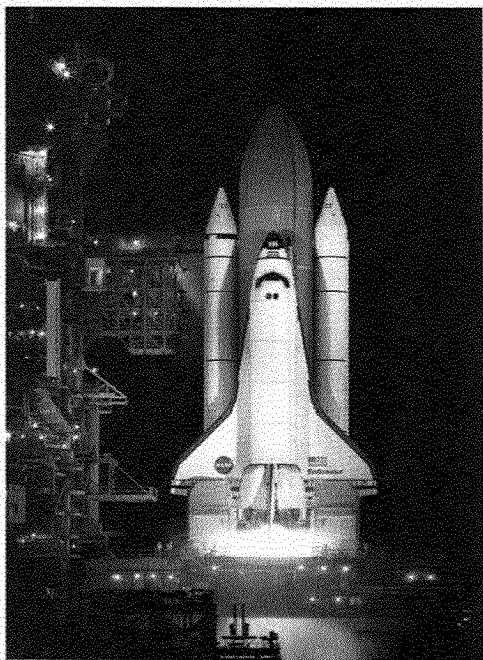

Careers in Photography

Advertising	Military
Aerial	Multimedia
Agricultural	Nature
Archaeological	Oceanographic
Architectural	Photo editor
Commercial	Photojournalism
Documentary	Portrait
Educational	Real estate
Entertainment	Scientific
Fashion	Sports
Fine art	Stock
Fire	Studio
Forensic	Travel
Industrial	Underwater
Magazine	Wedding
Medical	Wildlife

How to Prepare

Learn by doing. Look for ways to get experience as a photographer. Join a camera club. Take pictures for your school newspaper or club newsletters or websites. Get a summer or part-time job with a local newspaper, photo studio, or camera store. Assist and learn from an experienced photographer. Cultivate a good eye for composition and your artistic sense. Submit your best work to magazines.

Learn to use computers and specialized software to edit digital images. Take art classes to learn about design and composition. Depending on your career goals, you also might need to know about business, advertising, journalism, printing, publishing, physics, chemistry, or electronics.

Many universities, community colleges, and vocational-technical schools offer photography courses. As a photography student, you will learn about equipment, processes, and techniques.

Getting a job in photojournalism or industrial or scientific photography generally requires a college degree in journalism or photography with internship experiences. Photographers working in any field must have good technical skills, whether they gain their skills through experience, a degree program, or vocational-technical training.

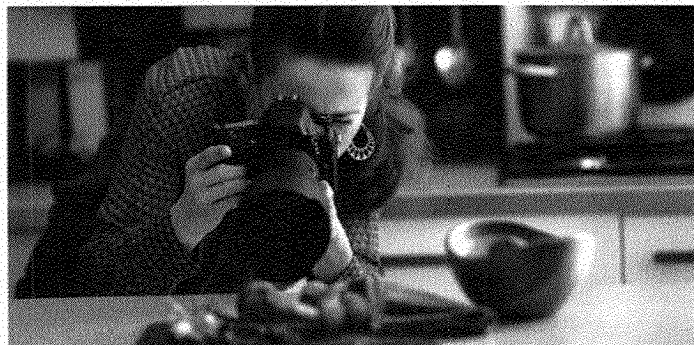



Glossary

action. The activity or movement that you are photographing. The best action shots are taken at moments when the action is at its peak.

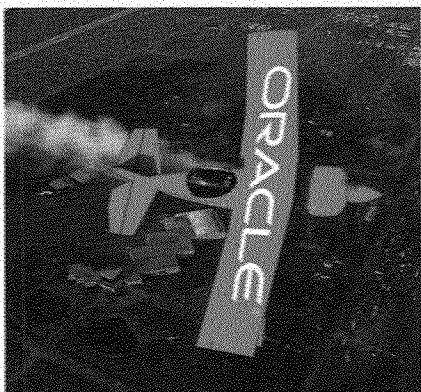

additive primaries of light. Red, green, and blue (RGB), which are the major sections of the visible portion of the electromagnetic spectrum. These colors combined in equal proportions create white light. Imaging sensors in cameras work using RGB receptors.

AIR. An acronym standing for action, interaction, and reaction. Photographers look for ways to capture each of these elements in their pictures.

ambient light. Existing light.

aperture. Lens opening; the opening in a lens system through which light passes. The size of the aperture is either fixed or adjustable. Lens openings usually are indicated by f-numbers.

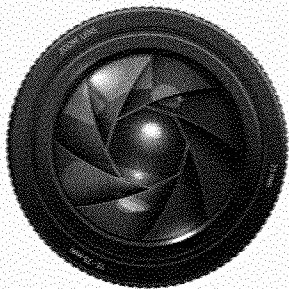

automatic camera. A camera with a built-in exposure meter that automatically adjusts the lens opening, shutter speed, or both for proper exposure.

automatic focus. A system by which the camera adjusts its lens to focus on a given area; for example, whatever is at the center of the image.

AWB. An acronym standing for automatic white balance. This camera setting adjusts photos to look natural when taken under light sources with various color tones.

background. The part of the scene that appears behind the main subject of the picture.

burning. Using image adjusting software to darken part of a photo.

camera angles. Various positions of the camera (high, medium, or low; and left, right, or straight on) with respect to the subject, each giving a different viewpoint or effect.



composition. The arrangement of all elements in a picture: main subject, foreground, background, and supporting subjects.

contrast. The difference in darkness or density between one tone and another. Also, using different forms, textures, colors, etc., in a composition to emphasize their differences for artistic effect.

cool. Bluish colors that, by association with common objects (water, ice, etc.), give an impression of coolness.

cropping. Using software to reframe a portion of the original image. This is usually done to enhance composition or eliminate distracting elements. Cropping can increase the visual impact of a picture.

daguerreotype. The first practical photographic process, developed by Louis-Jacques-Mandé Daguerre in 1839.

depth. A photograph has depth when two or more areas of the picture, from front to back, have something interesting to look at.

depth of field. The distance range between the nearest and farthest objects that appear in acceptably sharp focus in a photograph. Depth of field depends on the lens opening, the focal length of the lens, and the distance from the lens to the subject.

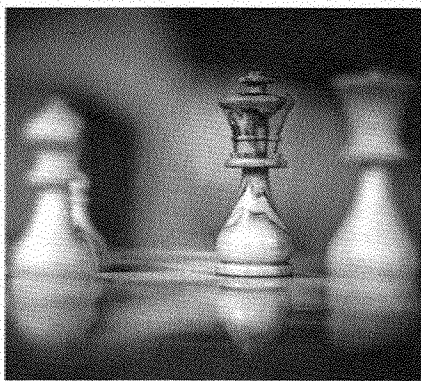

dodging. Using image adjusting software to lighten part of a photo.

editing. The process of selecting, arranging, and preparing images and image sequences.

enlargement. A print that is larger than the negative or slide; blowup.

existing light (available light). Strictly speaking, existing light is any type of natural lighting from moonlight to sunshine. By definition for photographic purposes, existing light is the light that is already on the scene and includes room lamps, fluorescent lamps, spotlights, neon signs, candles, daylight through windows, outdoor scenes at twilight or in moonlight, and scenes artificially illuminated after dark.

exposure. The quantity of light used in making a photo; a product of the intensity (controlled by the lens opening) and the duration (controlled by the shutter speed) of light striking the digital sensor in the camera.

exposure setting. The lens opening and shutter speed selected to expose the digital sensor.

film. The material used in a film camera to record a photographic image. Generally it is a light-sensitive emulsion coated on a flexible acetate or plastic base. Film remained the dominant form of photography for more than a century before advances in technology drew consumers to digital formats.

filter. A colored piece of glass or other transparent material used over the lens to emphasize, eliminate, or change the color or density of the entire scene or certain elements in the scene.

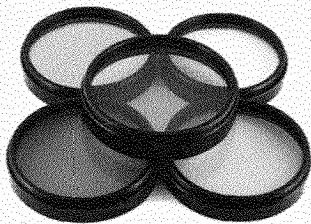

flash. A brief, intense burst of light produced by an electronic flash unit, usually when lighting on the scene is inadequate for picture-taking.

focus. The position at which rays of light from a lens meet to form a sharp image.

focus statement. A single declarative sentence describing a story that you plan to tell in one or more pictures. Developing that sentence ahead of time will help you focus your attention on the reason for the photographs.

foreground. The part of the scene that appears in front of the main subject of the picture.

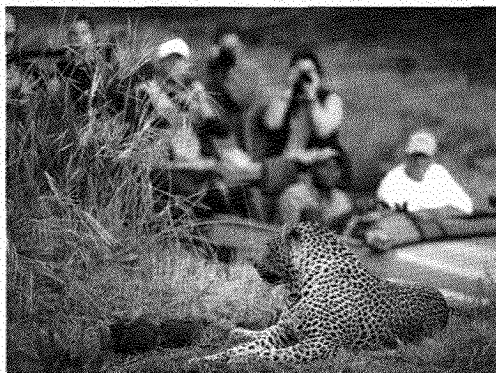

f-stop. A number used to indicate the size and light-passing ability of the lens opening on most adjustable cameras. Common f-numbers are $f/2.8$, $f/4$, $f/5.6$, $f/8$, $f/11$, $f/16$, and $f/22$. The larger the f-number, the smaller the lens opening. In this series, $f/2.8$ is the largest lens opening and $f/22$ is the smallest.

image adjustment. Anything done to an image after the exposure is made to enhance the look of the picture such as adjusting the tonal range or color balance.

image sensor. The device in the camera that converts light from the image into electrical signals to create a digital file.

interaction. Action or visual communication between people or subjects in a picture.

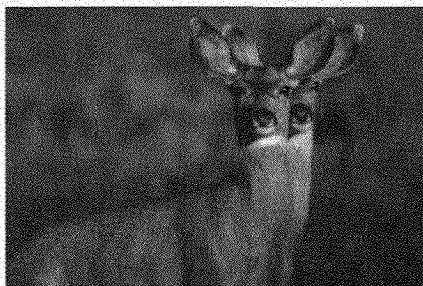

ISO. A numerical rating that describes the sensitivity of a camera's digital sensor to light. The ISO rating doubles as the sensitivity to light doubles.

lens. A piece or several pieces of optical glass shaped to focus an image of a subject.



light meter. An instrument that measures the light reflected from or falling on a subject; used as an aid to selecting the exposure setting.

noise. Digital artifacts generated in a digital picture that are not part of the scene. These are generally present when using a high ISO with a small digital sensor. (See *ISO*.)

normal lens. A lens that makes the image in a photograph appear similar to what the human eye sees. A normal lens has a wider field of view than a telephoto lens and a narrower field of view than a wide-angle lens.

pixel. Short for picture element. Images are composed of many individual pixels, each having a specific color or tone that can be displayed, changed, or stored. When the pixels are small enough, the eye merges the individual pixels into continuous tones.

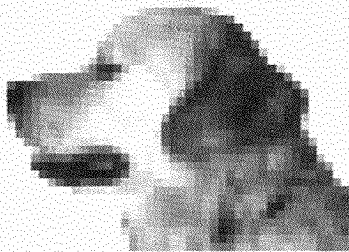

print. A hard copy of a photograph.

reaction. The visible result of action or interaction in a photograph, typically seen in captured facial expressions.

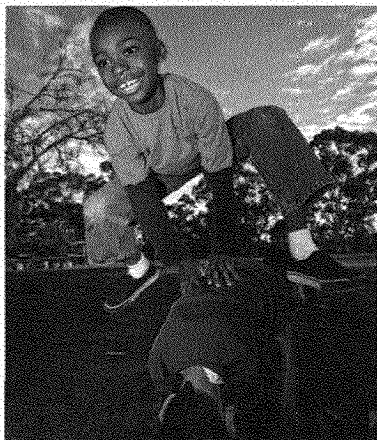

resolution. The fineness of detail in a digital image, often expressed as the number of pixels per inch (ppi) in a displayed image or the number of dots per inch (dpi) in a printed image.

RGB. (See *additive primaries of light*.)

sensor. The feature in a camera that detects an image and translates that information to create the image.

sharp. Showing crisp, precise texture and detail; the opposite of blurred or soft.

shutter. The blades, curtain, plate, or other movable cover in a camera that controls the time during which light reaches the digital sensor.

single-lens reflex (SLR) camera. A camera in which the scene to be photographed is viewed through the same lens that takes the picture. A mirror reflects the scene onto a piece of glass where it can be focused and composed.

smartphone. Smartphone is a generic label for handheld phones that do much more than make phone calls. They are small computers with a myriad of apps to do our bidding.

subtractive primaries. The pigment or ink colors of cyan, magenta, and yellow. These inks, in various proportions, can produce any color in the visible spectrum on a printed page. Only these inks are used to reproduce color photographs in a magazine or newspaper. A fourth color of black is printed only in the deep shadow areas and for text. These inks are the ones used in printing pictures from a computer sent to a printer.

tonal range. The difference in light intensity between highlights and shadows in a scene. This is also called dynamic range.

warm. Reddish colors that, by association with common objects (fire, sun, etc.), give an impression of warmth.





Photography Resources

Scouting Literature

Art, Communication, Journalism, Moviemaking, and Theater merit badge pamphlets

With your parent's permission, visit the Boy Scouts of America's official retail website, www.scoutshop.org, for a complete listing of all merit badge pamphlets and other helpful Scouting materials and supplies.

Books

- Burian, Peter K., and Robert Caputo. *Photography Field Guide: Secrets to Making Great Pictures*, 2nd ed. National Geographic, 2003.
- Busch, David D. *Mastering Digital SLR Photography*. Cengage Learning PTR, 4th ed., 2014.
- Davies, Paul Harcourt. *The Complete Guide to Close-Up & Macro Photography*. David & Charles, 2002.
- Eastman Kodak Company, editors. *The Joy of Photography*. Perseus Publishing, 1991.
- Frost, Lee. *Teach Yourself Photography*, 2nd ed. McGraw-Hill, 2008.
- Grimm, Tom, and Michele Grimm. *The Basic Book of Digital Photography: How to Shoot, Enhance, and Share Your Digital Pictures*. Plume, 2009.
- Kelby, Scott. *The Digital Photography Book: Part 1*, 2nd ed. Peachpit Press, 2013.
- . *The Photoshop Elements 14 Book for Digital Photographers*. New Riders, 2015.
- London, Barbara, John Upton, et al. *Photography*, 11th ed. Pearson, 2013.
- Long, Ben. *Complete Digital Photography*, 8th ed. Cengage Learning PTR, 2014.
- Norton, Boyd. *Boyd Norton's Outdoor Digital Photography Handbook: How to Shoot Like a Pro*. Voyageur Press, 2010.
- Peterson, Bryan. *Understanding Exposure: How to Shoot Great Photographs With Any Camera*, 4th rev. ed. Amphoto Books, 2016.
- . *Understanding Shutter Speed: Creative Action and Low-Light Photography Beyond 1/125 Second*. Amphoto Books, 2008.

Sammon, Rick. *Rick Sammon's Complete Guide to Digital Photography: 107 Lessons on Taking, Making, Editing, Storing, Printing, and Sharing Better Digital Images*, 2nd ed. W.W. Norton, 2007.

Shaw, John. *John Shaw's Guide to Digital Nature Photography*. Amphoto Books, 2015.

Stuckey, Scott. *National Geographic Ultimate Field Guide to Travel Photography*. National Geographic, 2010.

Tharp, Brenda. *Extraordinary Everyday Photography: Awaken Your Vision to Create Stunning Images Wherever You Are*. Amphoto Books, 2012.

Periodicals

Digital Photo Pro
Telephone: 617-706-9110
Website:
<http://www.digitalphotopro.com>

News Photographer
Telephone: 706-542-2506
Website: <http://nppa.org/page/news-photographer-digital-archive>

Popular Photography
Website: <http://www.popphoto.com>

Shutterbug
Telephone: 321-269-3212
Website: <http://www.shutterbug.com>

Organizations and Websites

American Society of Picture Professionals

201 East 25th St., No. 11C
New York, NY 10010
Telephone: 516-500-3686
Website: <http://aspp.com>

Canon USA

Website: <http://learn.usa.canon.com>
Learn by studying great photography tips from the pros.

International Association of Panoramic Photographers

Website:
<http://www.panoramicaassociation.org>

National Press Photographers Association

120 Hooper St.
Athens, GA 30602-3018
Telephone: 706-542-3018
Website: <https://nppa.org>
The National Press Photographers Association has a provision for student membership, and <http://competitions.nppa.org> has a monthly clip contest where you can study award-winning photographs and videos.

National Press Photographers Foundation

Website: <http://nppg.org>
The National Press Photographers Foundation funds college scholarships for students who are enrolled in four-year programs. See the website for details of how to enter.

Photographic Society of America

8241 S. Walker Ave., Suite 104
Oklahoma City, OK 73139
Telephone: 855-772-4636
Website: <http://psa-photo.org>

Professional Photographers of America

229 Peachtree St. NE, Suite 2200
Atlanta, GA 30303
Telephone: 404-522-8600
Website: <http://ppa.com>

Visual Storytelling

Website: <http://storytellingonline.info>
Dr. James Brown's website featuring composition tips and more, using many Scouting examples.

White House News Photographers Association

Website: <http://whnpa.org>

Acknowledgments

The Boy Scouts of America thanks the following members of the National Merit Badge Subcommittee, who diligently worked to develop the merit badge requirements and content for this pamphlet.

James W. Brown, Ph.D.—team lead; Eagle Scout; Silver Beaver recipient; executive associate dean emeritus, Indiana University School of Journalism; scholarships chair and board member, National Press Photographers Foundation; recipient of many photography awards including gold and bronze medals at the International Film and TV Festival of New York.

David Carlson—photography lead; Eagle Scout; Silver Beaver recipient; member of Camera Craftsmen of America; award-winning master photographer with more than 30 years of experience; advisor at Canon USA Inc.

Randy Piland—Eagle Scout; 30-year professional photojournalist and former U.S. Army photojournalist; college-level photojournalism and publication design teacher; experience includes covering numerous world and national Scout jamborees.

Steve Bowen—Distinguished Eagle Scout; Silver Buffalo recipient; chair, New Merit Badge Task Force; member, Advancement and Program Content committees.



Michael Roytek, BSA staff photographer; Master Photographer David Carlson; Janice Downey, BSA senior strategic innovation; Randy Piland, freelance photographer; and Jim Brown, Ph.D., executive associate dean emeritus, Indiana University School of Journalism

Photo and Illustration Credits

- James Brown, courtesy—pages 13, 21, 23 (*Civil War reenactment*), 29 (*blacksmith*), 33 (*Order of the Arrow ceremony, mountain barn*), 38, 44, 53 (*Delaware Indian*), 56 (all), 57 (*excited Scout*), 58, 68 (*mules*), and 72
- David Burke, courtesy—pages 6, 16, 25, 31, 32, 51, and 70 (*deer*)
- Canon USA, courtesy—cover (*camera*); pages 34 and 35
- David Carlson, courtesy—pages 12, 15, 19, 22 (*photographer*), 23 (*camera on tripod*), 26 (*Tooth of Time*), 27 (*pilot in spiral*), 40, 41, 53 (*manatees*), 63, 66, and 67 (*plane*)
- Randy Piland, courtesy—page 60
- Robert Rogers, courtesy—pages 7, 14, 27 (*track runner*), 29 (*foot washing*), 30 (*climber*), 33 (*rappeller*), 47, 55, 57 (*Scout blowing horn*), and 75
- Shutterstock.com—cover (*aperture*, ©Vectomart); pages 9 (*antique camera*, ©Gavran333), 10 (©NorGal), 24 (©Art_Photo), 36 (©TungCheung), 39 (©Oleg Belov), 42 (*eye icon*, ©DVARG), 43 (©mrkornflakes), 45 (*color circles*, ©Arcady; *apple*, ©olegganko), 61 (*copyright symbol*, ©valdis torms), 62 (*underwater photographer*, ©fenkieandreas; *sunset*, ©Jaromir Chalabala; *wedding photographer*, ©vipubadee), 65 (*forensics photographer*, ©Couperfield; *winter shot*, ©aaltair; *food photographer*, ©Alliance), 67 (*aperture*, ©Vectomart), 68 (*chess pieces*, ©Oleg Ivanov IL), 69 (*filters*, ©DeSerg; *leopard*, ©Villiers Steyn), 70 (*light meter*, ©Carlos Yudica; *pixelated image*, ©Alexey V Smirnov), and 71 (©Grisha Bruev)
- Wikipedia.org, courtesy—pages 8 and 9 (*George Eastman*)
- All other photos and illustrations are the property of or are protected by the Boy Scouts of America.
- Tom Copeland—cover (*Scout photographer*); pages 17, 28 (*boardwalk*), and 49
- Greg Crenshaw—page 48
- Seth Gitner—page 29 (*cyclist*)
- Jeff Hattrick—page 77
- Ron Kuenstler—pages 30 (*drummer*) and 61 (*divers*)
- Greg Luer—page 46
- Roger Morgan—page 54
- Randy Piland—pages 20, 22 (*sunset*), 26 (*Vietnam Veterans Memorial*), 28 (*hikers in woods*), 37, 50, and 53 (*Scouts*)
- Jesse Scofield—pages 5 and 27 (*Scouts on bridge*)



MERIT BADGE LIBRARY

Though intended as an aid to youth in Scouts BSA, and qualified Venturers and Sea Scouts in meeting merit badge requirements, these pamphlets are of general interest and are made available by many schools and public libraries. The latest revision date of each pamphlet might not correspond with the copyright date shown below, because this list is corrected only once a year, in January. Any number of merit badge pamphlets may be revised throughout the year; others are simply reprinted until a revision becomes necessary.

If a Scout has already started working on a merit badge when a new edition for that pamphlet is introduced, *they may continue to use the same merit badge pamphlet to earn the badge and fulfill the requirements therein.* In other words, the Scout need not start over again with the new pamphlet and possibly revised requirements.

Merit Badge Pamphlet	Year	Merit Badge Pamphlet	Year	Merit Badge Pamphlet	Year
American Business	2019	Family Life	2016	Plant Science	2018
American Cultures	2013	Farm Mechanics	2017	Plumbing	2012
American Heritage	2013	Fingerprinting	2014	Pottery	2008
American Labor	2018	Fire Safety	2019	Programming	2019
Animal Science	2014	First Aid	2019	Public Health	2017
Animation	2015	Fish and Wildlife Management	2014	Public Speaking	2013
Archaeology	2017	Fishing	2013	Pulp and Paper	2019
Archery	2019	Fly-Fishing	2014	Radio	2017
Architecture and Landscape Architecture	2014	Forestry	2019	Railroading	2019
Art	2013	Game Design	2019	Reading	2013
Astronomy	2019	Gardening	2013	Reptile and Amphibian Study	2018
Athletics	2019	Genealogy	2013	Rifle Shooting	2012
Automotive Maintenance	2017	Geocaching	2019	Robotics	2016
Aviation	2014	Geology	2016	Rowing	2019
Backpacking	2016	Golf	2019	Safety	2016
Basketry	2017	Graphic Arts	2013	Salesmanship	2013
Bird Study	2019	Hiking	2016	Scholarship	2014
Bugling (see Music)		Home Repairs	2012	Scouting Heritage	2019
Camping	2019	Horsemanship	2013	Scuba Diving	2009
Canoeing	2019	Indian Lore	2008	Sculpture	2019
Chemistry	2018	Insect Study	2019	Search and Rescue	2018
Chess	2016	Inventing	2016	Shotgun Shooting	2013
Citizenship in the Community	2015	Journalism	2019	Signs, Signals, and Codes	2015
Citizenship in the Nation	2019	Kayaking	2019	Skating	2015
Citizenship in the World	2015	Landscape Architecture (see <i>Architecture</i>)		Small-Boat Sailing	2019
Climbing	2019	Law	2019	Snow Sports	2019
Coin Collecting	2017	Leatherwork	2017	Soil and Water Conservation	2019
Collections	2013	Lifesaving	2019	Space Exploration	2016
Communication	2013	Mammal Study	2014	Sports	2012
Composite Materials	2012	Medicine	2012	Stamp Collecting	2013
Cooking	2014	Metalwork	2012	Surveying	2004
Crime Prevention	2012	Mining in Society	2014	Sustainability	2013
Cycling	2017	Model Design and Building	2010	Swimming	2019
Dentistry	2016	Motorboating	2019	Textile	2014
Digital Technology	2014	Moviemaking	2013	Theater	2019
Disabilities Awareness	2016	Music and Bugling	2013	Traffic Safety	2016
Dog Care	2016	Nature	2014	Truck Transportation	2013
Drafting	2013	Nuclear Science	2019	Veterinary Medicine	2015
Electricity	2013	Oceanography	2012	Water Sports	2019
Electronics	2014	Orienteering	2016	Weather	2019
Emergency Preparedness	2019	Painting	2016	Welding	2016
Energy	2014	Personal Fitness	2019	Whitewater	2019
Engineering	2016	Personal Management	2019	Wilderness Survival	2019
Entrepreneurship	2013	Pets	2013	Wood Carving	2016
Environmental Science	2015	Photography	2016	Woodwork	2019
Exploration	2016	Pioneering	2019		

BOY SCOUTS OF AMERICA • SUPPLY GROUP

NATIONAL DISTRIBUTION CENTER

2109 Westinghouse Boulevard
P.O. Box 7143
Charlotte, NC 28241-7143

To place an order,
call customer service
toll-free 800-323-0736
or go to
www.scoutshop.org

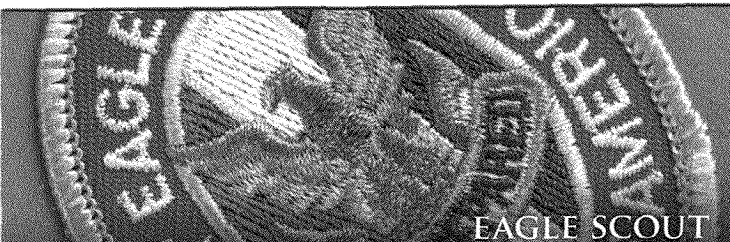

EAGLE SCOUT



THE SUMMIT



FLORIDA SEA BASE

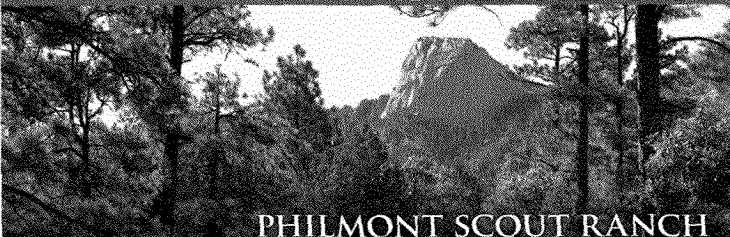

PHILMONT SCOUT RANCH

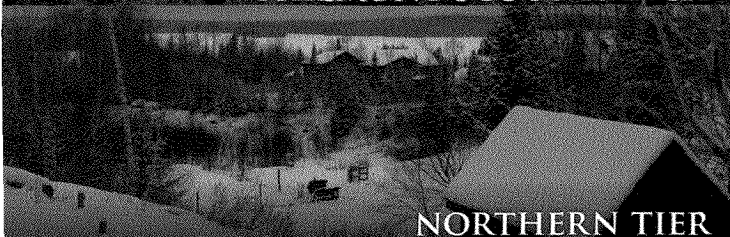

NORTHERN TIER

THE SUPPLY GROUP IS
READY TO BE A PARTNER
ON YOUR TRAIL TO
EAGLE THROUGH HIGH
ADVENTURE. THE
ADVENTURE IS YOURS.
AND WE ARE READY
WITH THE GEAR YOU
WILL NEED. YOU CAN
DEPEND ON THE LATEST
IN LIGHTWEIGHT,
DURABLE, QUALITY
GEAR THAT WILL
MEET AND SURPASS
YOUR TOUGHEST
REQUIREMENTS.



WWW.SCOUTSHOP.ORG

SKU 655192



35930

2020 Printin

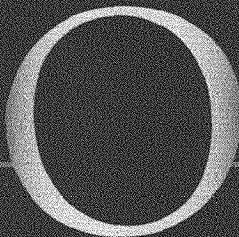

ON THE ROAD TO
HIGH ADVENTURE



Certified Sourcing
www.sfi-program.org
SFI-00558