

# MERIT BADGE SERIES

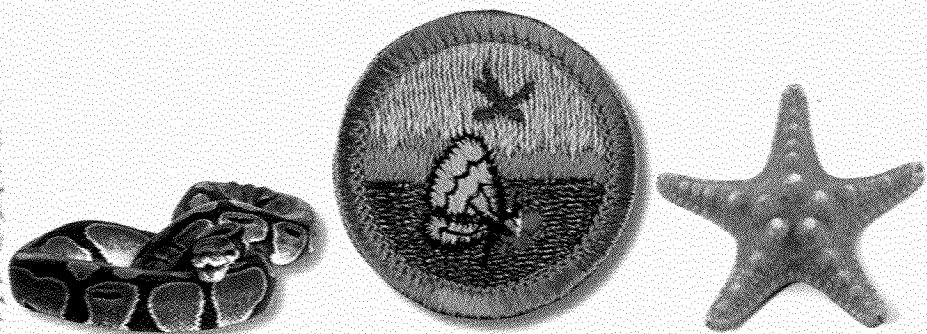

# NATURE



BOY SCOUTS OF AMERICA®

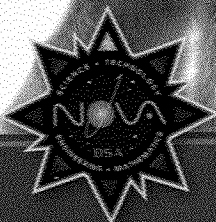

STEM-Based



BOY SCOUTS OF AMERICA  
MERIT BADGE SERIES

# NATURE



*"Enhancing our youths' competitive edge through merit badges"*



BOY SCOUTS OF AMERICA®

# Requirements

1. Name three ways in which plants are important to animals. Name a plant that is protected in your state or region, and explain why it is at risk.
2. Name three ways in which animals are important to plants. Name an animal that is protected in your state or region, and explain why it is at risk.
3. Explain the term “food chain.” Give an example of a four-step land food chain and a four-step water food chain.
4. Do all of the requirements in FIVE of the following fields:
  - a. Birds
    - (1) In the field, identify eight species of birds.
    - (2) Make and set out a birdhouse OR a feeding station OR a birdbath. List what birds used it during a period of one month.
  - b. Mammals
    - (1) In the field, identify three species of wild mammals.
    - (2) Make plaster casts of the tracks of a wild mammal.
  - c. Reptiles and Amphibians
    - (1) Show that you can recognize the venomous snakes in your area.
    - (2) In the field, identify three species of reptiles or amphibians.
    - (3) Recognize one species of toad or frog by voice; OR identify one reptile or amphibian by eggs, den, burrow, or other signs.

- d. Insects and Spiders
    - (1) Collect and identify either in the field or through photographs 10 species of insects or spiders.\*
    - (2) Hatch an insect from the pupa or cocoon; OR hatch adults from nymphs; OR keep larvae until they form pupae or cocoons; OR keep a colony of ants or bees through one season.
  - e. Fish
    - (1) Identify two species of fish native to your area.
    - (2) Collect four kinds of animal food eaten by fish in the wild.
  - f. Mollusks and Crustaceans
    - (1) Identify five species of mollusks and crustaceans.
    - (2) Collect, mount, and label six shells.
  - g. Plants
    - (1) In the field, identify 15 species of wild plants.
    - (2) Collect and label the seeds of six plants OR the leaves of 12 plants.
  - h. Soils and Rocks
    - (1) Collect and identify soils found in different layers of a soil profile.
    - (2) Collect and identify five different types of rocks from your area.
5. Discuss the principle of Leave No Trace and how it relates to nature.

\*Photos may be taken with your own equipment or gathered from other sources.

**Note:** In most cases, all specimens should be returned to the wild at the location of original capture after the requirements have been met. Check with your merit badge counselor for those instances where the return of these specimens would not be appropriate.

Under the Endangered Species Act of 1973, some plants and animals are or may be protected by federal law. The same ones and/or others may be protected by state law. Be sure that you do not collect protected species.

Your state may require that you purchase and carry a license to collect certain species. Check with the wildlife and fish and game officials in your state regarding species regulations before you begin to collect.



## Contents

Wildlife Communities . . . . .	6
Birds . . . . .	27
Mammals . . . . .	37
Reptiles and Amphibians . . . . .	41
Insects and Spiders . . . . .	45
Fish . . . . .	55
Mollusks and Crustaceans . . . . .	58
Plants . . . . .	61
Soil and Rocks . . . . .	65
Nature Resources . . . . .	69



## Wildlife Communities

Take a look around you. Are you inside your home or some other building that is made, in part at least, from wood? Are you outside where trees and other plants are important features of the landscape? Are your clothes made of cotton, wool, or leather? Did your breakfast include fruit or fruit juice? Cereal? Bacon and eggs? Milk?

Your clothing and your food come directly from plants or from animals that eat plants. Your home is made partly of wood, which is cut from another form of plants—trees. Your campsite is surrounded by plants of many types. Plants also produce the oxygen you need to breathe. You may never have paid much attention, but plants are very important in your life.

In much the same way, all other animal life is dependent on plants, and those plants depend on the soil. You could think of a plant as a type of factory that uses sunlight as power, and water and minerals from the soil as raw materials to make the food you need or the food that cows or sheep convert into milk, meat, leather, or wool for your use.

Even the largest animals are dependent on the soil for life. The way larger animals are linked to the soil through other small animals is called a *food chain*. The chain starts in the soil. There plants begin to sprout, drawing on the sun's energy to combine carbon dioxide, water, and minerals from the soil to make their own food. And the plants become food for many kinds of animals, from the tiniest worm or insect to the large deer.



**American chestnut**



For example, imagine a patch of clover, a favorite of some insects and animals, growing in a meadow. The clover blossoms are visited by a butterfly, and as it sips the nectar it suddenly is seized by a shrew, the smallest mammal in America and one of the hungriest. The tiny shrew makes short work of the butterfly and goes on the prowl again for something to satisfy its huge appetite.

But the shrew is careless, and suddenly it is pounced upon by a weasel looking for a quick meal.

The food chain progresses from the soil to the plant to a small animal to a larger animal and back to the soil—in this case with the death of the weasel, whose remains decay and nutrients return to the soil to be utilized by plants.

The plants that will grow in a particular wildlife community are dependent on that area's soil and climate. Under the influence of the region's soil and climate, plant life develops into different plant communities such as a forest, a marsh, a desert, or a prairie. These in turn support the wildlife community that lives there.

This very close connection between the soil, the plants, and all animal life is part of the web of nature. Each strand of the web depends on the other strands. The soil nurtures the plants. As they die and decay, the plants enrich the soil. The animals must have the plants to live. And when the animals die, their bodies decompose and help to make the soil more fertile.

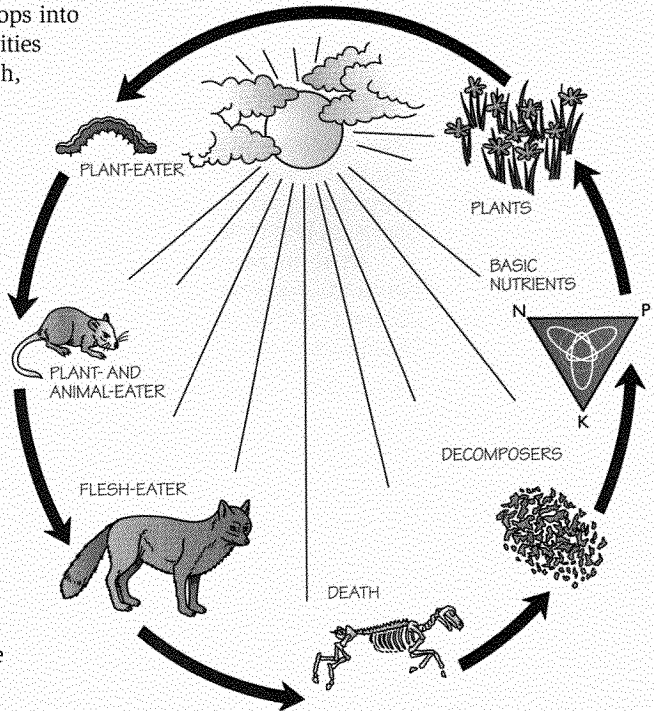

**Terrestrial food chain**



---

## The Importance of the Soil

A good soil is rich in humus. It holds water and plant foods. Nitrogen, the essential plant food element, is present only in the humus of the soil, not in the mineral grains.

---

The foundation of any wildlife community, whether on land or in the water, is the soil. If the soil is fertile, it will produce a flourishing plant growth. This will support a vigorous and abundant population of animals.

There are many different kinds of soil, and each will encourage different types of plant growth. To begin studying different soils on the land, first note whether the surface layer is sand, clay, or an in-between mixture called loam.

**Sandy Soil.** Water, wind, and weather conditions like frost can break rocks into tiny particles. When enough of these particles are gathered together, the result is sand. Sandy soil generally is not very rich in the minerals plants need to grow; consequently, pure sand does not support lush plant growth. Decayed plant and animal matter, or *humus*, contributes nitrogen and other elements to the soil. Thus, sandy soil that contains humus will be better suited for plant life.

**Clay Soil.** Clay particles are so small that you cannot see them individually, even under a microscope, and they tend to pack together. Clay generally is rich in minerals and holds water well, making it well-suited for most plant growth.

However, if soil particles are packed together too tightly or hold too much water, the seeds and roots of some plants will not get enough air.

**Loam.** Sand mixed with clay is called loam. Most loam soils also contain particles called *silt*, which are smaller than sand but larger than clay. *Silt loam*

is loam that contains a lot of silt. Loam soils are better for cultivation than sand or clay.

The water that flows from the soil also will carry dissolved minerals, a natural fertilizer that will permit a healthy growth of plants in the water. This will be the basis of the aquatic food chain and of populations of such animals as crustaceans, insects, fish, and terrestrial (land dwelling) animals like raccoons and otters, which depend in part on water life for their food.

## The Importance of Climate

The weather's impact on soil formation and on vegetation affects which plants will exist in a particular area. An area's average temperature and rainfall determine which plants will grow there.

Warm climates encourage rapid decay of plant and animal life, which results in a higher humus content. Richer soils are loamy, well-supplied with humus, and nearly level. Lowlands along river bottoms usually have deep, rich soils. Sloping land can be highly fertile and as productive as level land, but water is likely to run off and carry the rich soil with it. Areas where rainfall is low tend to have rich soil because the minerals have not been leached away, but plants may not be able to fully use these nutrients because of the limited water.

Certain plants grow well in warm climates but cannot exist in a cold environment, and some plants can grow only in cooler climates. For example, cabbage palms, live oaks, and certain cacti grow in warm climates, while balsam fir, aspens, and spruces grow only where winters are cold.



---

You cannot judge a soil by looking at the surface alone. Look under the surface and see what the subsoil is like. A clay subsoil that slowly absorbs water is not as rich as a subsoil that easily lets water and air into it.

---

In the same way that plants have soil requirements, they have requirements of temperature range—from hot to cold.



Altitude also affects plant life: The higher you go, generally the colder the temperature and the higher the rainfall. As far as plants are concerned, going up the side of a mountain is much the same as going north. Going up 300 to 500 feet of altitude is roughly equivalent to moving northward one degree of latitude (68 miles). So, the same plants will grow at a higher elevation in the South than in the North. Trees that will not grow at 4,000 feet in one place might grow at 6,000 feet farther south.

So critical are the forces that affect wildlife communities—soil, temperature, rainfall, and altitude—that an experienced naturalist can tell you what plants and animals can and can't be found there, if these factors are known.

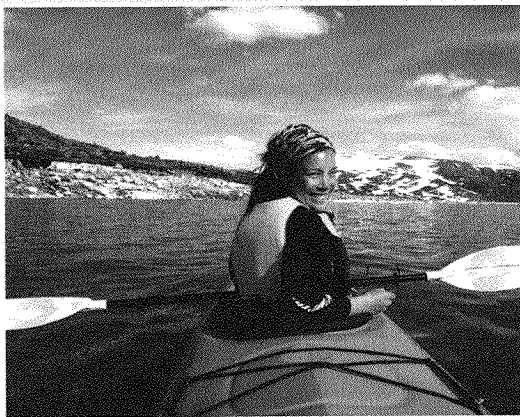

Some forces can change or influence the wildlife community relatively quickly. Windstorms, floods, drainage, and fire might destroy a community or create a new one. These same influences also might cause sudden growth of certain insects or populations, thus causing more damage and costing much in control efforts.

In some places, sudden windstorms such as hurricanes or tornadoes might blow down trees and thus change the nature of the community. When trees are blown down, more sunlight reaches the ground and low-growing plants that don't thrive in the shade. It will take some years for seedling trees to grow and shade out these shrubs.

Steadily blowing wind is a long-range influence in places such as mountaintops, seacoasts, and deserts. The constant power of the wind causes trees to grow gnarled and bent instead of straight and tall. Other plants that normally grow tall also hug the ground because of the wind.

## Water as a Wildlife Community

Just as a forest, prairie, desert, or marsh supports a particular type of wildlife community, so does a pond, lake, stream, river, bay, or ocean. Many of the same forces help determine what kinds of plants grow in water and, in turn, these plants help to determine what kinds of animals will be found.

Like plants on dry land, water plants need light to manufacture food. That is why the most luxuriant plant growth—pickerel weed, cattails, bulrushes, wild rice, arrowroot, or pond lilies—are found in shallow water where the leaves can obtain pure sunlight.

Strange as it might seem, a storm that blows down all or many of the trees in an area might help increase some wildlife populations.

Where plant life is affected by the wind, animal life differs, too. Animals usually will seek protection from the wind.

## What Makes Water Plants Grow

- The amount of water and the stability of the water level
- Water depth and clarity
- Water temperature
- The speed of water flow
- The kind of floor the body of water possesses
- The minerals in the water and in the soil beneath
- The condition of the land surrounding the water
- Whether the water is fresh, salt, or brackish

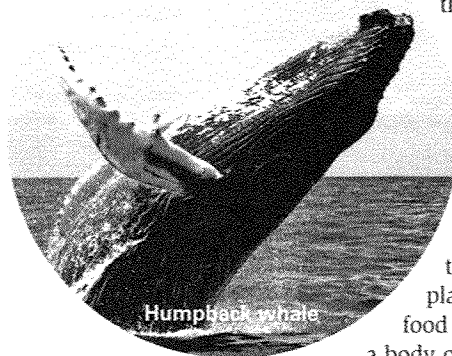

Humpback whale

Where the water is too deep for rooted plants, small floating plants that you cannot see without a microscope take over. What these plants lack in size they make up for in numbers. There are millions of them. Living among and on these tiny plants will be equally tiny animals. Together, the plants and animals are called *plankton*, and they provide food for water animals from small fish to whales.

While plankton is important in the food chain of water animals, rooted plants are important to them for both food and shelter. The kind of floor beneath a body of water helps determine which plants

will grow there. Muddy bottoms usually will support

plants different from those supported by rock, gravel, or sand bottoms. Some hard clay bottoms might not support plants at all.

Water movement also affects plant life. Delicate, long-stemmed plants like pickerelweed and lilies grow well in lakes or ponds, where the water moves slowly. In swiftly running streams or rivers, you would find low-growing or ribbonlike plants able to withstand the fast current. Generally, mosses and algae are found on the rocks in fast-moving water.

Temperature, too, is important to plant life in the water. If the temperature of water is very cold or covered with ice, plant growth is slowed. Sunlight, oxygen, and carbon dioxide cannot penetrate the ice and reach the plants, and these plants remain inactive most of the year.

The condition of the land surrounding a pond, lake, or stream is critical to aquatic life. Plankton need minerals to live. Minerals get into water through rainwater that drains off the land watershed into ponds or streams. If this land has been farmed out, burned over, or in some way exhausted of minerals, then the water is not as likely to contain the minerals required by plankton and other plants and animals.

---

In places where the water level varies because of spring floods and summer droughts, the plants along the edge will be different from a place where the water level is the same the year-round.

---

## Salt Water

A few plants will grow in both freshwater and salt water, but relatively few freshwater plants can tolerate any salt in the water. For instance, salt marshes are periodically flooded with salt water, and only plants that will tolerate salt water can grow there.

The most obvious plants growing in salt water are the *seaweeds* that anchor to rocks or shells, or grow on sandy or muddy bottoms. Water temperature and movement determine which of these plants will grow there, just as in freshwater. A few will grow in both cold and warm water. Some of the more common seaweeds are sea lettuce, bladder wrack, the kelps, gulfweed, Ceylon moss, Irish moss, and rockweed.

Some seaweeds grow only in shallow water where they are exposed by low tide. Others grow in water that is 100 or more feet deep. Still others grow from the low-tide line to fairly deep water.

Some plants are so sensitive to salt that they cannot grow where salt spray reaches them.

## Plants in the Wildlife Community

One thing all plants have in common is that they are constantly subject to change. In nature, change typically is a gradual process interspersed with occasional abrupt, drastic changes such as a forest fire, too many animals grazing in one area, or clearing the land for a highway. When the vegetation of a plant community is all or partially removed, the community will gradually rebuild itself.

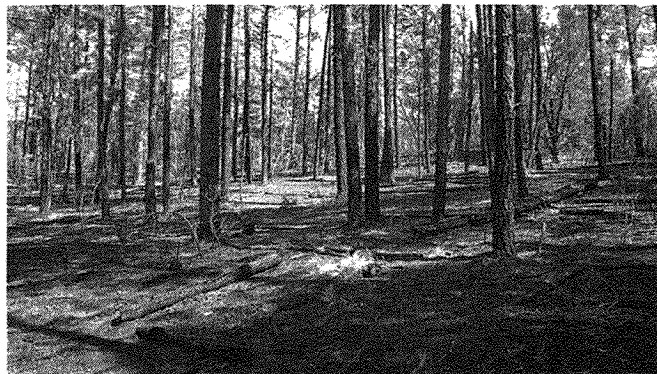

With few exceptions, most of the plant communities you will see have been greatly modified. The few areas that remain unmodified, such as wilderness areas, continue to provide valuable information about how natural systems evolve as part of the ecosystem. They are among our most valuable natural history possessions.

---



When seeds are blown into the bare soil, annual plants such as common garden or roadside weeds will begin to spring up. Perennial plants and grasses might get started at the same time, and they soon will crowd out the annuals. Then depending upon the climate and other conditions, grasses will grow more dominant or shrubs and trees will take over. Sometimes these stages are cut short, especially if there is a good seed year and such trees as birch or white pine are nearby.

In the Northeast, for example, shrubs like the sumac might grow, along with gray birch, black cherry, and aspen. Their leaves would enrich the soil, and as the trees grow they would shade the ground. Other trees such as the red maple and oak can get started under these steady conditions. In some parts of the Northeast, the oak would remain as the dominant species of tree, but in other areas, the oak would, in time, give way to beech and sugar maple. Under their denser shade, nothing but their own seedlings would grow. This then would be the last stage in the succession, a *climax forest*.

In the grasslands of the Midwest, much the same thing would happen. First, annual plants would dominate the bare soil, then perennials and grasses. But instead of trees moving in, grasses would remain as the final stage. In the Rocky Mountain area, trees would form the last step in the succession, but trees such as pine, spruce, and fir would dominate instead of the hardwood of the East. This process of plants replacing each other as each creates certain conditions favorable to the growth of the next stage is called *plant succession*. The last stage to grow naturally in any area is called the *climax community*.



When the climax community has been reached, no other plants can replace that growth unless the climate changes or disaster strikes—wind, fire, volcanic actions, flooding, or human actions. In this event, however, the same succession will occur again, with the same climax growth appearing in the end.

## Water-to-Forest Succession

Many climax forests and prairies now stand where there was once a pond, lake, or beaver-dammed stream. In almost the same way that bare soil will finally be replaced by the area's climax growth, plant life may overtake water and the area would become a forest or prairie.

Briefly, this is what happens. First, only water and a mineral bottom exist. As the plants that live in the water or along the shore grow and die over many years, a layer of organic material forms at the bottom of the pond. Finally, a bed of organic matter and mineral debris washes down from the surrounding land, replacing the pond water, and a bed of peat reaches the surface. When suitable soil has formed, other plants, like sedges or cattails, grow and form a mat. As these plants grow and die, they help build up the soil so that still other plants can grow.

Next come the grasses and sedges that form sod. As they grow, they form solid soil. Eventually they will move out over the peat, and the peat will develop farther out toward the center of the pond.

### Water-to-forest succession

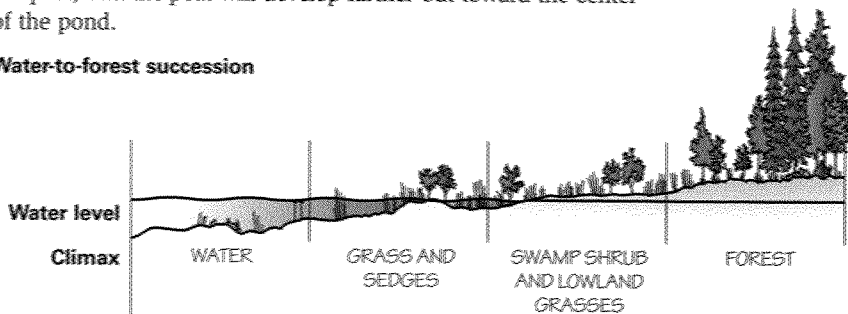

When a prairie is the climax, the final stage will succeed the lowland prairie grass stage. Where a forest is the climax, trees such as elm, ash, or red maple succeed the swamp shrubs.

Because climate changes and disasters are a normal part of nature, the wildlife community is dynamic, always changing here and there, but continually moving toward the climax stage.

Sod-forming plants can grow in soil that is dryer than what the first two groups of plants need. When the sod-formers have helped build up a suitable soil, and a sufficient amount of water has been replaced, still different plants will grow. These plants might be swamp shrubs or lowland prairie grasses, depending on the climax.

## Animals in the Wildlife Community

From microscopic species in the soil, through insects, worms, and other animals beneath the surface, to mammals such as woodchucks and ground squirrels that nest underground, to insects, reptiles, birds, and mammals that live on the surface and up into the highest trees, all animals live in close relation to one another and to plants.

Many animals eat plants. Insects eat grasses or tree leaves, or live under the bark of trees where they find food; reptiles such as certain species of turtles and lizards live mainly on plants; some fish eat plant life in the water; birds eat fruits, seeds, and buds; mammals such as squirrels eat seeds; wild deer eat acorns, twigs, and tree leaves and buds.

Animals might also eat other animals. Some insects eat other insects; some snakes, turtles, and lizards, as well as amphibious frogs and salamanders, eat insects, while other snakes eat small mammals. Some fish eat insects or smaller fish. There are birds that eat insects, fish, mammals, and other birds. Some mammals eat insects, snakes, fish, birds, or smaller mammals.

In each case, the animal contributes to the health of the wildlife community. For example, rodents in a grassland area eat the grasses. Hawks, owls, foxes, and coyotes feed on rodents and help keep rodent populations at moderate levels. Birds such as woodpeckers, bluebirds, flycatchers, and warblers eat insects that in excessive numbers may be harmful to trees.



## HIPPO

The World Wildlife Fund uses the acronym HIPPO to summarize the leading causes of why a species becomes endangered.

H = Habitat loss

I = Introduced (invasive) species

P = Pollution

P = Population growth (of humans)

O = Overconsumption (in industrialized nations)

## A Balanced Wildlife Community

The expression “balance of nature” refers to the relationships between animals and their environment and among animals within that environment.

In the natural arrangement of things, prey animals live on plentiful plant foods and they have lots of young—far more than can survive for very long. This overproduction, or population surplus, is largely to feed the flesh-eaters, called *predators*.

Because they eat the overproduced animals, predators do not reduce their food supply much. And, because they help to keep the population of plant-eaters within reasonable limits, the *herbivores* do not destroy their own food supply.

In other words, one thing tends to balance another to keep the system operating. The numbers of predators are partly determined by the ease with which they can obtain food and rear their young. When the flesh-eaters have had easy living for a while and their populations build up, another “control” enters the picture. Under high population density, disease spreads readily, reducing the population.

The numbers of animals perpetually fluctuate with the annual cycle of the seasons and from year to year. First one species is plentiful and then another. But it all happens within certain limits, and for that reason the balance of nature is a real thing. Otherwise communities of plants and animals could not survive.

In our human communities, almost every person has responsibilities that in some way affect others. Some people raise food. Others raise animals or plants that provide us with clothing. Still others work to provide us with homes, education, good health, electricity, transportation, and all other products or services we need in everyday living. We all depend on someone else for those things we cannot make or do for ourselves.

---

Each plant and animal in a wildlife community has a function or role in that community, and the welfare of all depends on the continued interaction of each of these to keep the community in balance.

---

In nature, every wildlife community supports a different group of animals. City dwellers are different from those in a forest, those found in a city park are different from those in a desert, and animals around a farm or ranch are different from those in a marsh or swamp.

## Animal Succession

Every animal has its own requirements for food, cover, and water. Several kinds of animals might eat the same food, but their other needs will differ. Or, they might have similar requirements for cover, but they will eat different food.

Probably the easiest way to illustrate this is to review plant succession and note that each stage of the succession will support different animals. Let's start with bare ground and see what typical animals might be associated with each stage.



Ring-necked pheasant

### Stages of Succession on Land

**Bare Soil.** Because there is nothing to eat, very few animals are found at this stage.

**Early Weed Stage.** This provides a slightly better environment for animals than bare soil. The grasses and weeds that grow provide seeds for ground-feeding birds such as field sparrows and horned larks, and for certain kinds of mice. Some patches of bare ground still exist, and the early weeds do not provide much cover for animals.

**Late Weed Stage.** In this stage, such plants as broom sedge, quack grass, asters, goldenrod, pokeweed, and poverty cat grass might support a few nesting birds. An occasional pheasant or quail might feed on seeds, and winter birds such as the tree sparrow, snow bunting, or junco might find food. Rabbits and meadow mice can find food and cover.

**Prairie Subclimax.** When plants such as Kentucky bluegrass and clover move in and form a sod cover, the area becomes better suited for animals. Insects will make their home there, which will attract insect-eating birds. Cover is available for birds like the meadowlark, which will then nest. Food and cover also are available for rabbits and many rodents. Consequently, food is provided for animals such as foxes or hawks, which will feed on the small mammals and birds.

**Prairie Climax.** If grass is the climax growth, the next (and final) stage, consisting of long-lived perennial grasses, will supply food and nesting cover for several other animals. Now other species of prairie birds, such as the upland plover and grasshopper sparrows, can be found. Jackrabbits, ground squirrels, badgers, coyotes, and red foxes might also move in because they will find food and shelter there. But generally, the subclimax supports more animal life than pure stands of climax growth.

**Shrub Stage.** If forest is the climax growth, a shrub stage will succeed the perennial weed or grass stage. Birds such as the chipping sparrow, cardinal, and indigo bunting will nest among shrubs like sumac, sassafras, witch hazel, and prickly ash. Bees will nest in the ground, and typical shrub insects like damsel bugs and assassin bugs will be found. Cottontail rabbits will find cover they need, as will bobwhite quail.

**Subclimax Tree Stage.** As larger trees replace the shrubs, still other animals will be found. Tree-nesting birds like blue jays, cuckoos, crows, flickers, flycatchers, warblers, and hawks will be found. Insects that live under tree bark or in deadwood will find food and homes for the first time. Mammals such as deer, squirrels, opossums, raccoons, and bears can find suitable food and cover for their needs.

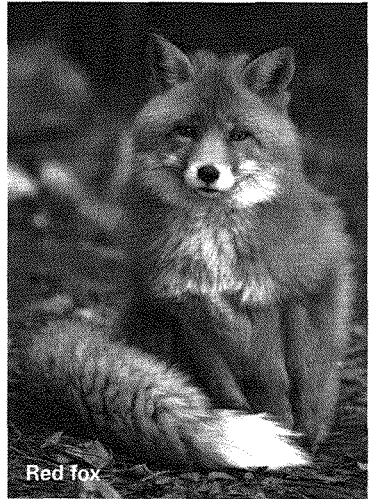

Red fox



Prairie warbler

**Climax Forest.** Although some of the same animals found at the subclimax tree stage also will be found in climax forests, many of them will be replaced by animals that find more favorable conditions in the climax forest.

### Stages of Succession in Water

Much like the way particular land animals are found at certain stages of succession, certain types of animals are associated with each stage of succession in water.

**Open Water.** In open water, few animals are seen. There might be fish such as bass, and down deep there might be lake trout. A few diving ducks, such as mergansers, might find food there. An osprey might catch a fish near the surface of the water. Animals such as clams or mussels might be found on the bottom.

**Submerged Plant Stage.** In shallower water, plants such as algae and pond weed will live and provide food for more animals. Insect larvae live on these plants and provide food for fish such as sunfish or crappie. Bass also will be found here because they feed on small sunfish and insects.

**Floating Plant Stage.** In this stage, water lilies and smart weeds grow. Fish will find food and shelter among the underwater stems, and frogs might be seen on lily pads or in the water. Such birds as herons find food here.



Mallard hen

### Reed Marsh Stage.

When cattails, bulrushes, and reeds grow, the pond has become more of a marsh than a pond. Mammals such as muskrats now find food and cover; red-winged blackbirds, yellow-headed blackbirds, coots, rails, and some ducks will nest. Mink will be at home here because there is plentiful animal life on which to feed.

**Sedge Meadow Stage.** When sedges, rushes, and spike rushes take over, the succession has become a sedge meadow. Here bobolinks will find food and nesting sites, and marsh hawks or short-eared owls search out mice for food. The next stage may be prairie or shrub, and the associated animals will closely resemble the succession from bare ground to forest or prairie climax.

## How Humans Affect the Wildlife Community

Humans sometimes affect wildlife communities in obvious ways. Marshes might be drained for agriculture, housing developments, or airport construction; large areas might be flooded by dams. In the process, a wildlife community with its distinctive plant and animal life is destroyed and another is created, although it is no longer natural.

Forests might be cut to provide timber, chemicals, paper pulp, or other products needed in everyday life. Carelessness might cause fires that destroy forests and the animals that live in them. These events set back the wildlife community to an earlier state of succession.

Prairies might be plowed for agriculture to grow more food for people. But many of the animals and plants that can live only on the prairie will disappear from these areas.

To some extent, wildlife communities also can be created. Farm ponds, farm marshes, hedgerows between cultivated fields, shrubby roadsides, and similar projects are, in a sense, wildlife communities that might not have existed in the area before but, after being created by people, become homes for wildlife.

Humans also affect wildlife communities in less obvious ways. We might upset the balance of a community and affect the plants and animals that live there. In a lake, for example, anglers may catch only the bass, leaving too few bass to eat the

Sometimes, trees are cut down to create better hunting conditions. Cutting down trees gives low-growing plants a chance, which in turn provides food and cover for so-called game animals. This is one way in which humans influence the wildlife community, but it is done only after careful study and research, and under certain conditions. The succession is set back to and held at the stage thought desirable for the particular animals wanted.

A wildlife community can be destroyed through the introduction of exotic or foreign species, foreign diseases, pests, bounties on predators, and similar human acts.

surplus bluegills. There soon will be so many bluegills that there is not enough food for them. Then the pond will contain only bluegills too small to catch and a few large bass that won't go after bait or lures because they will have enough food. In the meantime, the bluegills will eat bass eggs, so the bass cannot multiply.

In another example, it might appear that hawks or foxes are killing all the pheasants or quail in an area. Although the logical solution might appear to be to eliminate many of the hawks or foxes, this will not necessarily increase the number of pheasants or quail. If there is not enough of the right kind of food and cover for the birds, their numbers will not increase anyway. Enough food and cover might help the bird population grow, even with foxes and hawks in the area.

Without the foxes and hawks, meadow mice might overrun the area and eat not only the crops, but also much of the food that pheasants need. The populations of other animals that are eaten by the hawks and foxes will also increase. The wildlife community will thus be out of balance, and all forms of life affected.

### Endangered Species

As civilization expands, it encroaches on areas used by wildlife. Also, of course, people who hunt and fish have reduced native populations. In the past, when "market" hunting was allowed, it caused massive destruction of wildlife populations. Today, game management helps control hunting in the United States so that the sport has not been responsible for putting certain species on the threatened or endangered lists.

The ivory-billed woodpecker, thought to have been extinct in the United States since the 1940s, has recently been rediscovered. Visual sightings and audio recordings by scientists in 2004 and 2005 suggest that individual birds may still exist in a few remote areas in Arkansas and possibly Florida.

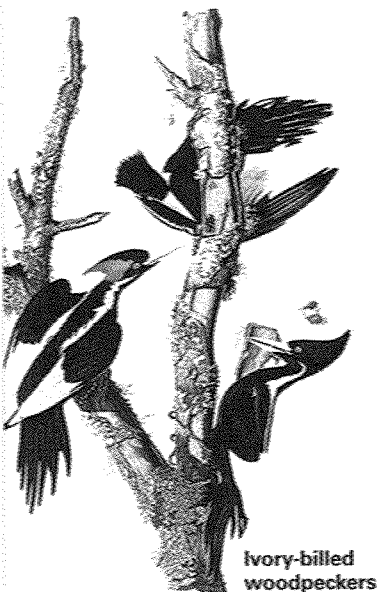

Ivory-billed woodpeckers



Our state and national park systems and the efforts of many private groups are evidence of our attempt to preserve wildlife communities. But the pressure of a growing population makes it increasingly difficult to keep these areas natural.

You can find out what plants and animals are protected in your state by contacting your state's natural resources department, or by visiting the U.S. Fish and Wildlife Service website: <http://ecos.fws.gov/ecos/indexPublic.do>.

### Domestic Animals

Because domestic animals are raised for food, clothing, or recreation, their influence on wildlife communities is part of how humans affect the environment.

Cattle, sheep, and horses all feed on plant life, especially grasses that are cultivated just for their use. But just as the food supply in a wildlife community limits the number of animals that can live there, the plant life in an area where domestic animals graze limits the number of animals that the land can support. Too many animals can eat the grass down to where it weakens and dies. This *overgrazing* can destroy a community in which wild animals also live, so that wild birds and mammals that live there have no food or cover. The animals will starve, or the rancher must supply more food.

In some places, cattle or sheep grazing in forested land has a harmful effect on plants and wild animals. Cattle or sheep eat too much of the ground cover and, by walking over the ground day after day, pack the earth so that water cannot penetrate the soil. When it rains, the water runs off quickly, taking soil with it. This washes into streams, making them unsuited for fish. Floods might occur if too much rain falls. The lack of ground cover in the forest also affects the wild animals that depend on it for food or cover; these animals will die or move away.

Where overgrazing has occurred—that is, where domestic animals have destroyed the original plant life and the ability of the soil to produce grass of a high quality—the nature of the community changes.

When breeding populations can no longer keep up with natural causes of death, certain species become endangered and might become extinct. Once extinct, a species can never be reproduced and it is lost forever.

---

Where a prairie meets a woodland, where a hayfield meets a cornfield, where a marsh blends into woods, or wherever two communities come together, you will find a larger variety of animals.

---

Meanwhile, the forest itself is harmed. First, the packed earth prevents water from reaching tree roots, and the growth rate of the trees slows down. Part of the ground cover in the forest is made up of seedlings that will replace the large trees when they grow old and die. Domestic animals often eat these seedlings, killing them completely or causing them to become deformed.

### Look Along the Edges

As you observe wildlife communities, you will discover that the best places to find animals are where two communities meet. This “edge” produces more wildlife than either of the communities. Here, you will find a greater variety of plants, which supply more food and more cover for more animals.

For example, rabbits find food in fields where clover grows. But they need tangle or brush for cover from their enemies. Where a field meets a shrubby wood, rabbits have food and cover close together and therefore can live successfully.

However, even though a greater variety of wildlife can be found along the edge, some animals avoid the edges and require large stretches of a certain type of terrain, such as an unbroken forest.



When invasive (nonnative) species are introduced to an area, they compete and—over time—often overtake native species. Invasive species can ultimately throw off the delicate balance of the wildlife community.

## Principles of Leave No Trace

Do your part to keep nature natural by following these principles.



**1. Plan ahead and prepare.** Proper planning and preparation increases safety, reduces the impact of your visit on the environment, and helps make your outdoor experience more enjoyable.



**2. Travel and camp on durable surfaces.** Natural environments are easily damaged by foot traffic. Use existing trails or travel on durable surfaces such as rock, gravel, sand, compacted soil, dry grasses, or snow. Large groups should spread out to avoid creating new trails. Keep campsites small.



**3. Dispose of waste properly (pack it in, pack it out).** Any material people leave behind pollutes the environment and might create a health hazard for wildlife or other visitors. Pack out any trash and leftover food. Dispose of human waste by digging catholes 6 to 8 inches deep and 200 feet away from water, trails, and campsites.



**4. Leave what you find.** Observe the interesting things you find, but do not disturb them. Use established campsites and do not alter them in any way. Restore campsites to pristine condition before you leave.



**5. Minimize campfire impacts.** Use a lightweight stove when cooking in the backcountry. If you need to build a fire, keep it small and use only dead or downed wood. Never cut down limbs or trees for firewood.



**6. Respect wildlife.** Stay far enough away from animals that your presence does not disturb their natural activity. Store food, food scraps, and trash securely to prevent animals from eating food that is not part of their natural diet. Never feed wild animals.



**7. Be considerate of other visitors.** Let everyone enjoy nature. Travel and camp quietly and away from other people. Blend in by wearing subdued colors. Leave pets and portable audio devices at home.

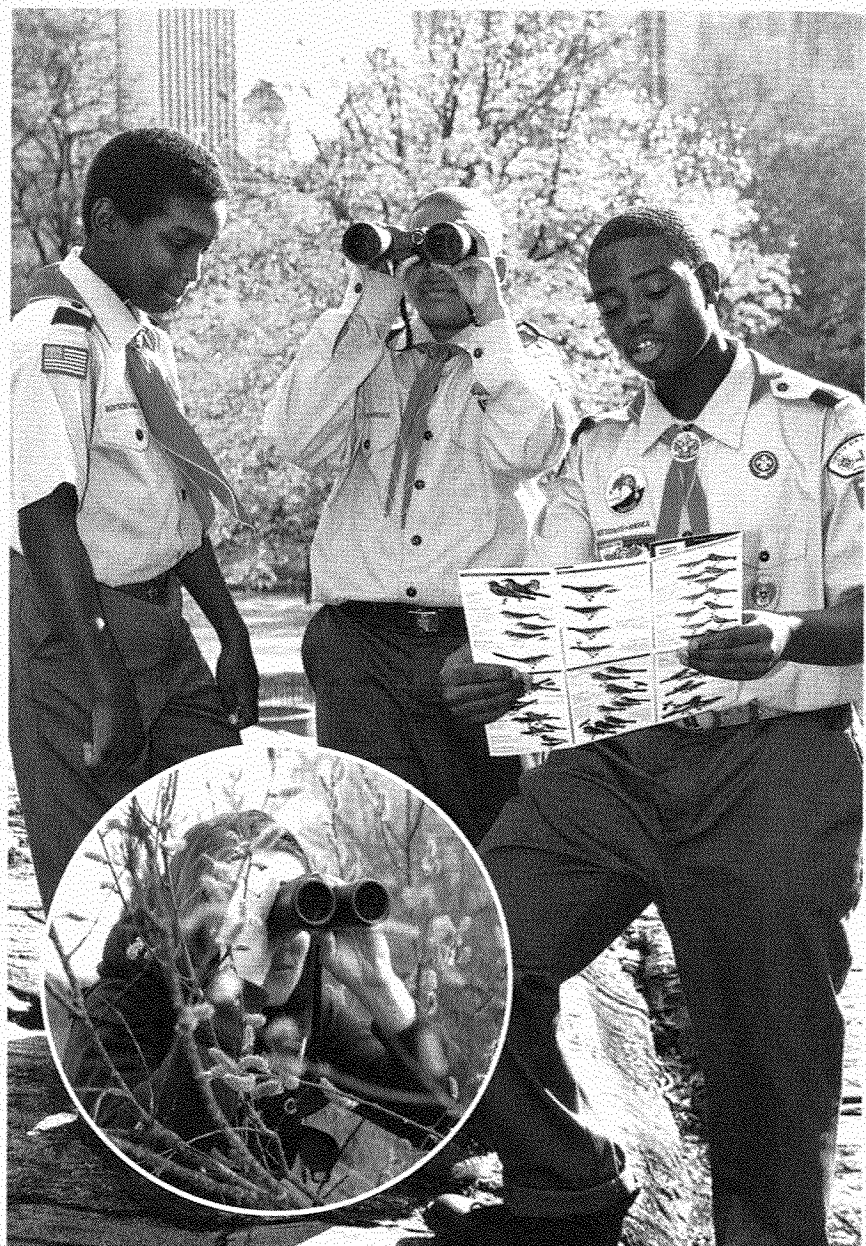

# Birds

The best way to learn to identify birds is to venture outside and look and listen for them. If your counselor or someone else who knows birds can go with you, so much the better. If not, your task will be more difficult, but you can do it by yourself. First, borrow a pair of binoculars or field glasses. They will make bird watching much more fun and identification much easier.

Next, learn something about bird families and where they usually are found. For example, if you wanted to see ducks, you would look at a body of water. If you wanted to see woodpeckers, you would look in trees. If you wanted to see meadowlarks or killdeers, you would look in fields or meadows.

When just beginning to bird-watch, first try to place a bird in the correct family grouping. Determining the species will then be easier. Generally, the common birds you will see may be placed in one of the following groups.

**Wading Birds.** Herons, egrets, and bitterns are in this group of birds, which have long legs, long necks, and long, pointed bills. You usually see them wading in shallow water watching for small fish.

**Waterfowl.** Ducks and geese are in this group and usually are seen on or near water or marshes. Ducks are divided into two groups: those that feed by tipping up and dabbling in shallow water and those that dive for food.

---

When looking at birds, always try to have the sun at your back. When the sun shines on the bird from behind you or from a slight side angle, you can see any color clearly. Otherwise, all you might see is a black silhouette in a treetop or floating on a pond.

---

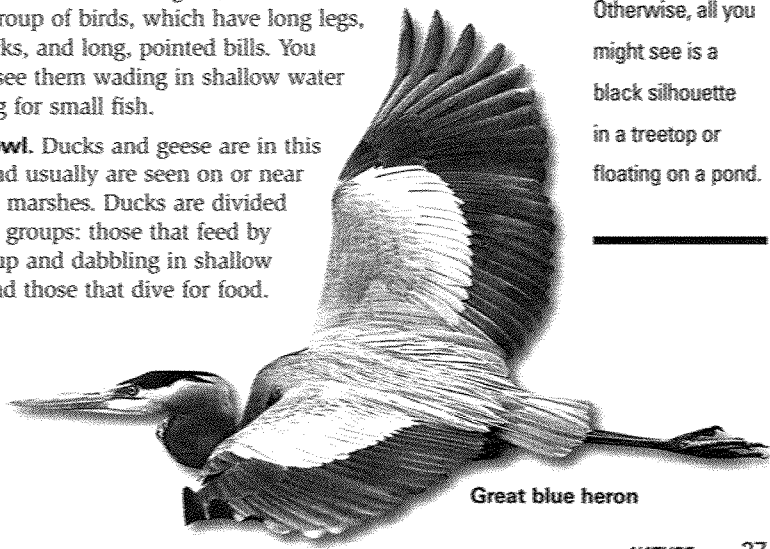

Great blue heron



Harris hawk

**Birds of Prey.** Hawks, vultures, and eagles are in this group of generally large birds. They have hooked beaks and strong feet and feed on small animals such as mice and rats, amphibians, snakes, fish, and other birds. You usually see them soaring overhead or perched in a snag from which they watch for prey.

**Grouse and Quail.** These are birds that somewhat resemble chickens. Some are found in brushy areas, others in fields or prairies. Prairie chicken, ruffed grouse, spruce grouse, and sage hens are in this group. Quail are smaller than grouse and are easily distinguished from them. These birds usually are seen on the ground.

**Shore Birds.** This is a group of small wading birds found along streams, ponds, or the seashore. Some kinds live in fields and prairies. They have long, probing bills and probe for small water animals or grubs in the soil. Sandpipers, killdeer, snipe, and woodcock are in this group.

**Gulls and Terns.** These are long-winged, strong flying birds found near large bodies of freshwater or salt water. Gulls usually feed on the surface, while terns dive for their food. Herring gulls, ring-billed gulls, western gulls, California gulls, black terns, common terns, and least terns are probably the most common birds in this group.



Common tern

**Woodpeckers.** Flickers, sapsuckers, and red-headed, downy, and red-bellied woodpeckers probably are the most common birds in this group. They usually are seen climbing tree trunks and probing the bark for insects. In flight, they flap several times then pause, which gives them an up-and-down sort of flight.

**Flycatchers.** These birds generally perch on bare twigs or power lines, once in a while flying off to catch an insect. While perched, they sit quite still, occasionally jerking their tails. King birds, phoebes, and flycatchers are the most common birds in this group.

**Swallows.** These are smallish birds with long, slender wings seen most often as they fly gracefully over fields or water, chasing insects. Tree swallows, barn swallows, and martins are members of this group.

**Jays.** In general, jays are birds of the woodlands, where their large size, long tails, and bluish or gray color help identify them. Blue jays and Florida jays are found in the East; magpies, California jays, and Steller's jays are found in the West.

**Thrashers.** This is a group of robin-sized birds with slender bills, which generally curve downward. They are seen on the ground or in low shrubs. Mockingbirds, catbirds, and thrashers are in this group.

**Thrushes.** This group includes the robin, bluebird, and thrush. With the exception of the bluebird, all generally are brownish on the back and have speckled breasts. They all are known for their beautiful songs and usually are seen feeding on the ground.

**Warblers.** These small, brightly colored, insect-eating birds have fine bills and flitting habits. They are birds of the woodlands, usually seen at the tops of trees or at the tips of shrub branches. Some of them are myrtle warblers, Audubon's warblers, yellow warblers, and black-and-white warblers.



Gila woodpecker

American robin

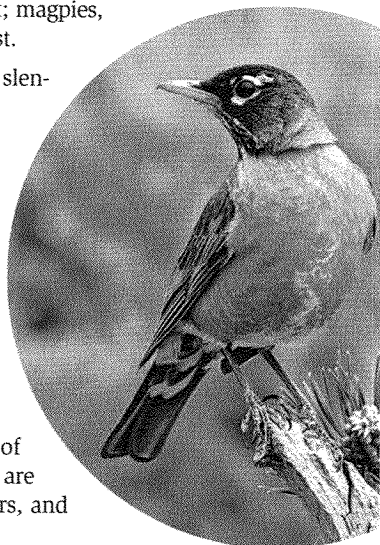

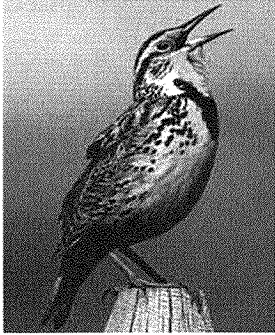

Western meadowlark

**Meadowlarks, Blackbirds, and Orioles.** These birds are found in several wildlife communities: bobolinks, meadowlarks, and cowbirds in fields; orioles in high trees; grackles in marshes or woods; and redwings in marshes. Most of them are brightly colored, and all have distinctive songs.

**Finches and Sparrows.** Birds in this group all have strong, cone-shaped bills adapted for crushing or cracking seeds. They are found in almost all wildlife communities. Cardinals, grosbeaks, sparrows, towhees, and juncos are in this group.

As you watch birds, find out as much as you can about them. Noticing the following things about a bird will help you recognize the species the next time you see it:

- Its call
- Its song
- What it eats
- How it flies
- The trees or other plants it favors for perching and singing
- Where it nests
- Whether it walks or hops
- Specific markings such as an eye stripe, wing bars, and coloration

The easiest way to learn bird songs is to watch a bird while it sings, so you can immediately associate sight with sound. Some birds, however, might be heard and not seen. You can get help from someone else or one of the recordings of bird calls listed at the end of this pamphlet.

Learning about birds takes time. You will be surprised, however, that recognizing birds is quite easy and can become the basis of a lifelong hobby. There are more than 700 types of birds to be seen in the United States.



## Nest Boxes

Many birds—among them bluebirds, wrens, tree swallows, titmice, chickadees, and some ducks, hawks, and owls—nest in holes in hollow trees, known as cavities. Unfortunately, nest cavities are hard to find in many areas or have been taken over by starlings and house sparrows. By building nest boxes with properly sized holes, you can increase the populations of native cavity-nesting birds. At the same time, you will exclude invasive species such as starlings and house sparrows.

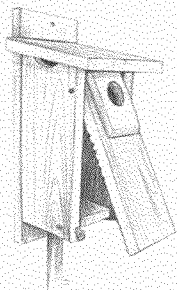

### Eastern Bluebird Nest Box

#### Materials List

- Standard 1" X 6", 4 feet long
- Standard board 1" X 10", 10½" long
- 1¾" galvanized screws, approximately 20
- Two 1¾" galvanized screws for pivot point
- One double-headed nail for holding door closed

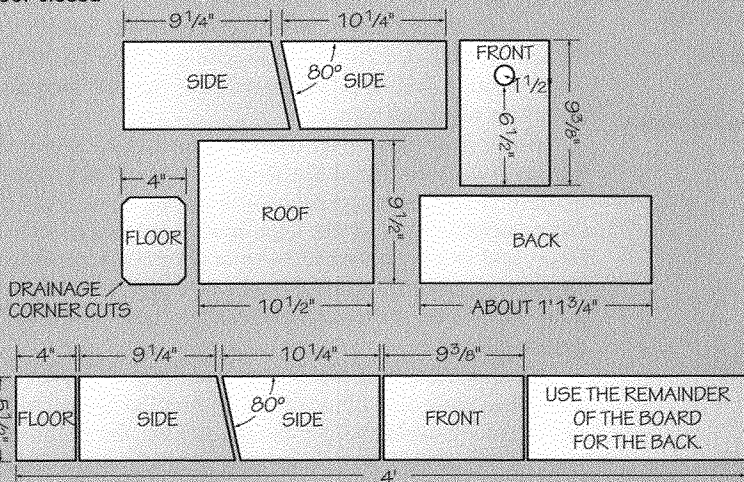
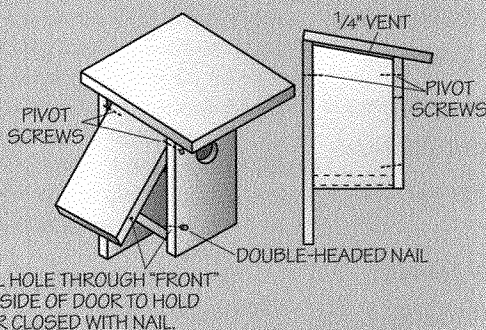

The nest box plans have been provided by the North American Bluebird Society. For more information about bluebirds and their conservation, visit the NABS website: [www.nabluebirdsociety.org](http://www.nabluebirdsociety.org).

Do not put a perch below the hole in your bird box. Native birds do not need one, and a perch makes it easier for house sparrows, starlings, and other predators to attack the birds nesting inside.

---

Do not build apartment boxes, except for martins.

---

The most effective nest box design is an upright rectangle with an overhanging roof and one hinged side for easy cleaning (see the plan provided in this chapter). The size of the entrance hole and overall dimensions of the box vary, depending on the species you want to attract, although a box with a  $1\frac{9}{16}$ -inch hole is ideal for a variety of birds, including bluebirds. Fancy or unusual designs, like those that imitate human houses, generally are not very effective or safe for birds.

Use  $\frac{3}{4}$ -inch, untreated lumber, not particle board or metal. Assemble the box using galvanized screws, which hold tighter and longer than nails. Be sure to drill several  $\frac{1}{4}$ -inch ventilation holes around the top of the side and back walls, and several more in the floor for drainage. It is not necessary to paint or stain the finished box, although a coat of gray or light brown stain or clear waterproof sealer will help preserve the wood. Avoid dark colors, which will make the box too hot in the sun.

Do not paint the entrance hole or inside of the box. If the lumber is smooth, use a sharp nail, rasp, or file to roughen the inside of the front of the box so the fledglings can easily climb to the hole. Saw kerfs may also be etched on the inside of the front panel.

Bluebirds like nest boxes placed in open country with low-cut grass and widely spaced trees and shrubs. Chickadees, wrens, and titmice prefer woodlands. Mount the box on a steel pole 6 feet off the ground. Wrap a 24-inch-wide metal cone around the pole or cover the pole with grease to discourage cats, raccoons, and other predators. Face the box away from the prevailing wind and rain.

If you place more than one box, space them at least 300 feet apart so that birds of the same species will not fight over territory. If you place boxes closer than this, be sure to observe them carefully. Birds of the same species may fight over the boxes, and you may need to move one. In other instances, different species may use the boxes. In either case, this is a great opportunity to learn how individual birds and different species interact.

Clean out boxes in late winter, removing old nesting materials, mouse nests, and other debris. During the nesting season, check the box weekly. When the parents are absent, quickly open the hinged side, count the eggs or chicks without disturbing the nest or its residents, note anything unusual about the nest materials, and record the results in your field notebook.

Then leave the area so the parents can return. Clean out the boxes after each nesting, and then inspect again in early spring prior to the nesting season.

Most songbird eggs hatch two weeks after the last egg is laid, and the chicks are ready to leave the nest in 14 to 21 days. Do not disturb the box during the last four or five days of this period, or the young birds might leave before they are ready.

### Other Nest Structures

Not all birds nest in tree cavities, but some of these species also can benefit from human assistance. Robins, phoebes, and barn swallows will nest on square wooden platforms mounted beneath the eaves of barns, sheds, or buildings, out of the wind and rain. Mourning doves, which build flimsy nests, will fledge more babies if you provide them with shallow cones of metal hardware "cloth," about 10 inches in diameter and wired into a crotch in the branches of a dense tree like a pine.



Barn swallow nest

### Mourning Dove Nest Basket\*

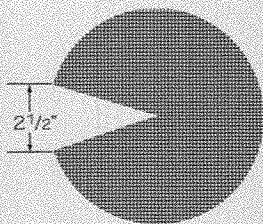
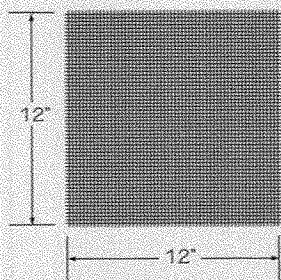
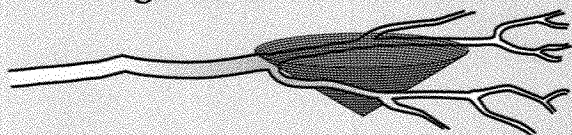

**Materials and tools:**  
one 12-by-12-inch piece  
of hardware cloth, wire,  
staples, tin snips



**Assembly:** Cut the cloth into a 12-inch circle. Cut out a 2½-inch pie piece from the circle and wire the edges together to form a cone, as shown. Wire and/or staple the cone securely into the crotch of a tree limb.

\*This plan comes from the Northern Prairie Wildlife Research Center. The NPWRC website can be found at [www.npwrc.usgs.gov](http://www.npwrc.usgs.gov).

Purple martins nest in colonies, usually in special "apartment house" nest boxes, or in hollow gourds. For more information on attracting martins, write to the Purple Martin Conservation Association, 301 Peninsula Drive, Suite 6; Erie, PA 16505; or visit its website at [www.purplemartin.org](http://www.purplemartin.org).

## Robin Nesting Shelter

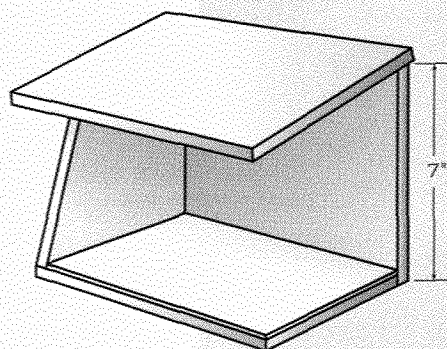

### Notes:

1. There is only one side.
2. Roof hangs over sides and front.
3. To assemble:
  - a. Nail through back into floor
  - b. Nail through side into floor and back
  - c. Nail through roof into side and back.

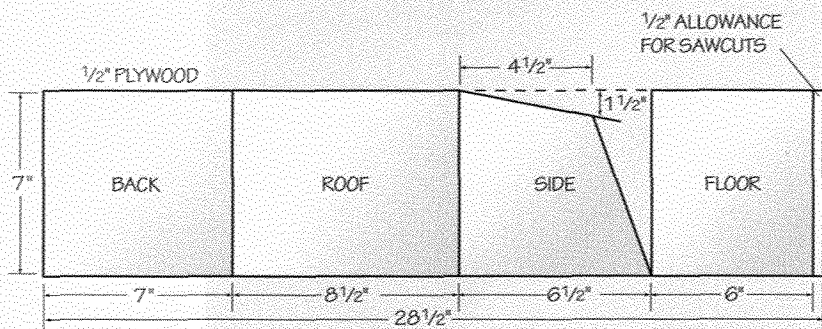

Robins will nest in shelters made with one or more sides open.

## Water

One of the best ways to attract birds to your backyard is to provide water. A simple, old-fashioned birdbath works well, as long as you keep it clean by scrubbing it every day or two with hot water and adding fresh water with a hose. You need only the bowl from a birdbath or a shallow plastic dish like those made to go under potted plants. Place the bowl directly on the ground near escape cover such as trees or bushes. Put a flat rock as big as your hand in the middle so that only an inch or so of water covers it. Some birds do not like to wade into deep water to bathe and can stand on the rock.

The sound of running or dripping water will attract birds from afar. Here's an easy project. Fill a clean, plastic milk jug with water and hang it several feet above a birdbath bowl or plastic dish on the ground. Put a flat rock in the bowl, and fill the bowl with water. Unscrew the cap of the jug slightly to allow air inside. Make a tiny hole with a needle or pin in the bottom of the jug so the water drips very slowly into the basin.



You can make a temporary birdbath by digging a shallow hole in the ground, removing any sharp stones or sticks, and then lining it with heavy plastic. Place gravel on the bottom, put rocks around the edge to hide the plastic, and fill it with water.



Striped skunk

# Mammals

At first, identifying three different wild mammals in the field might seem difficult. You might find rabbits, squirrels, chipmunks, or woodchucks rather easily, but depending on where you live or camp, other mammals might be more difficult to see. But if you start by looking for tracks or other signs, you will find that mammals are much more common than you think. Look for the following signs.

- Tracks in the mud or sand along waterways
- Signs of feeding around fruit-bearing shrubs or trees
- Rough bark around the hole in a hollow tree
- Droppings on animal runways in woods and fields
- Animal homes—holes in the ground, muskrat houses, or beaver dams

## Kinds of Mammals

In general, the mammals you are likely to see can be grouped as follows.

**Pouched Mammals.** The opossum is the only one in this country; they are different from other mammals because the females have a pouch in which to carry their young.

**Moles and Shrews.** Shrews are the smallest mammals—some only 2 inches long. They have pointed noses and short tails. They live in leaf litter on the forest floor or in tunnels under lawns and fields. They eat insects and sometimes snails. Moles have long, pointed noses, and their front legs are shorter than their back legs.



Shrew

**Bats.** These are the only flying mammals in this country. (Flying squirrels can actually only glide.) Bats have remarkable flight abilities. They nest in caves or hollow trees and feed on insects.

**Flesh-Eating Mammals.** This group includes some of the larger land mammals and most of the valuable furbearers. Bears, raccoons, martens, fishers, weasels, mink, otters, skunks, badgers, foxes, coyotes, wolves, bobcats, lynx, and cougars are included. Some of them eat plants, but all prefer to eat other animals and have canine teeth for tearing flesh. They live in many kinds of places; some are found in every kind of a wildlife community.

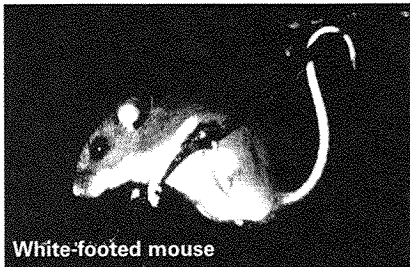

White-footed mouse



Elk

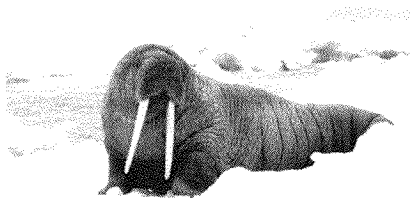

Walrus

**Rodents.** These animals are the gnawing mammals—mice, rats, woodchucks, marmots, porcupines, beavers, muskrats, nutria, chipmunks, squirrels, and gophers. This is the largest group in terms of numbers and different species.

**Rabbits.** Found in most parts of the country, hares and rabbits live in hedgerows, thickets, tangles, or holes in the ground. They have long hind legs and long ears. They eat only plants.

**Hoofed Animals.** Deer, moose, elk, mountain goats, bighorn sheep, bison, antelope, and wild pigs are in this group. They have hoofed feet and teeth adapted for cutting grasses and leaves. In general, they are long-legged and among the larger mammals. They usually are found in wilder areas.

**Water Mammals.** Whales, seals, walrus, porpoises, and dolphins live in the oceans. They may resemble fish, but the young are born live and feed on milk. They breathe air and must surface regularly for a fresh supply.

**Armadillos.** These animals have a shell-like skin, a pointed nose, and rather long ears. They eat insects, insect larvae, worms, and some plants.



## Plaster Casts

Animal tracks can be preserved for later study if you make a plaster cast of them. To begin, form a strip of cardboard into a circle, secure with tape, and place it around the track. Then mix some plaster of paris in a can of water until the texture resembles melted ice cream. Gently pour the plaster inside the cardboard mold, allowing the mixture to flow into the track. Do not pour the plaster directly into the track.

When working with plaster of paris, take care not to inhale the dust as you work. Also, wash your hands thoroughly with soap and water afterward.

The plaster will take about 20 to 30 minutes to harden. As it hardens, place a few short sticks across the plaster, inside the cardboard, and pour a little more plaster on top. The sticks will reinforce the plaster and keep it from breaking too easily.

When the plaster is hard, remove it from the mold and, using an old toothbrush or stiff brush, carefully brush off the dirt or sand that sticks to it. This cast is known as the *negative*, and with it you can make as many *positive* casts of that track as you want.

Next, decide what size of cast you want. Then make a wood frame that size.

To make the positive cast—that is, the cast that resembles the natural footprint—first coat the inside of the negative cast with petroleum jelly. Then lay the wood frame on a flat board and fill it with plaster of paris. Press the negative into the soft plaster and leave it there until the plaster is thoroughly hard. Then remove it from the mold, being careful not to crack the plaster. Before you forget it, write the name of the animal and the date on the flat top of the cast.

If the dirt or sand is too dry to make plaster casts of animal tracks, use a long-handled spray gun to spray shellac over the track from 4 to 5 feet away. Be careful not to blow away the sand or dirt. The shellac will hold the dirt in place so that you can make a plaster print of it.

---

The Nature merit badge requirements do not suggest that you collect or even touch wild animals. Remember that some animals might carry diseases and can be extremely dangerous.

---



Eastern spotted newt, red eft phase

# Reptiles and Amphibians

Before starting projects that will help you learn more about reptiles and amphibians, you should know what reptiles and amphibians are and how they differ from each other.

Reptiles include snakes, lizards, turtles, alligators, and crocodiles. When they are born, these animals look like their parents. All of them are born on land and all have lungs. They all have scales, plates, or shells.

Salamanders, frogs, toads, and newts are amphibians. All of these animals spend their early life in water or where it is quite moist. As they grow older, many of them change into entirely different looking animals. You may have seen tadpoles, which dart around in the water and somewhat resemble large-headed fish. Later, they grow legs and develop into frogs or toads. They then live on land or in the water and on land. They are called amphibians because they spend part of the time in water and part on land.

Some reptiles and amphibians are poisonous or can bite with painful results, so find out which ones to avoid before venturing into their habitat. Most amphibians are harmless, but some species of salamanders might give a nasty bite, and some toads might have a highly toxic secretion.



The giant toad secretes poisonous toxins dangerous to pets.

---

The word "amphibian" comes from a Greek word that means "leading a double life."

---



Arizona barred tiger salamander



The alligator snapping turtle bites with its beak—not its teeth.

Many reptiles are dangerous. There are four groups of venomous snakes, one poisonous lizard, and at least two turtles that can inflict painful bites. There are venomous snakes in nearly every state in the country. They are more abundant in some states and areas than in others.

Know what venomous snakes you might encounter so you can avoid them, and know how to render first aid if necessary.



Copperhead



Rattlesnake



Cottonmouth, or water moccasin

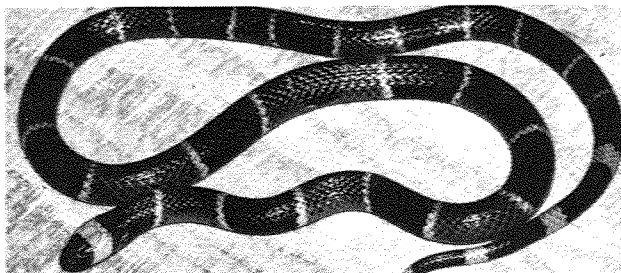
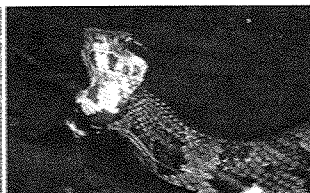

Eastern coral snake

## Timing Is Everything

The best time to look for reptiles and amphibians is in spring, as they emerge from hibernation, seeking food and the warmth of the sun, and hunt for their mates. All of these things, plus the fact that vegetation has not started to grow, make them much more conspicuous than they are at other times of the year.

Fall usually is the next best season to see reptiles. They seek sunshine for warmth again, and many gather near dens or burrows. Summer searching is unpredictable. You might find turtles, water snakes, and many varieties of frogs during hot weather, but most shun the heat and the sun. Others prowl only at night; sometimes it is profitable to look for them with a flashlight after dark. In areas with harsh winters, these animals hibernate during the cold weather and cannot be found.

## Toad and Frog Calls

Each species has a distinctive call. Some, like the spring peeper, have a high, piping note. Others, like leopard, wood, and pickerel frogs, make a noise that sounds like a snore or a grunt; the call of the green frog resembles a loose mandolin string; and the bullfrog's low "jug-o-rum" is well-known to almost everyone.

In the spring, frogs and toads sing day and night, but if you try to approach them in the daytime they will stop long before you reach them and you probably will never see them. They will dive out of sight or hide under vegetation. However, if you stalk them quietly at night, flashlight in hand, you may be able to watch them sing. Unless you can go out with your counselor or another expert, this is the best way to learn calls. Look for frogs and toads at night so you know which call belongs to which specimen.

Using a long-handled hook, tip up and then replace all objects beneath which something might hide. Reptiles and amphibians seek shelter under boards, flat or loose rocks, cracks in cliffs and ledges, rock slabs, and boulders. The sudden light may temporarily dazzle specimens uncovered in this way. Other specimens may quickly dash to other cover. Be sure to look carefully since some will be almost hidden by the soil or leaf litter.



Spring peeper

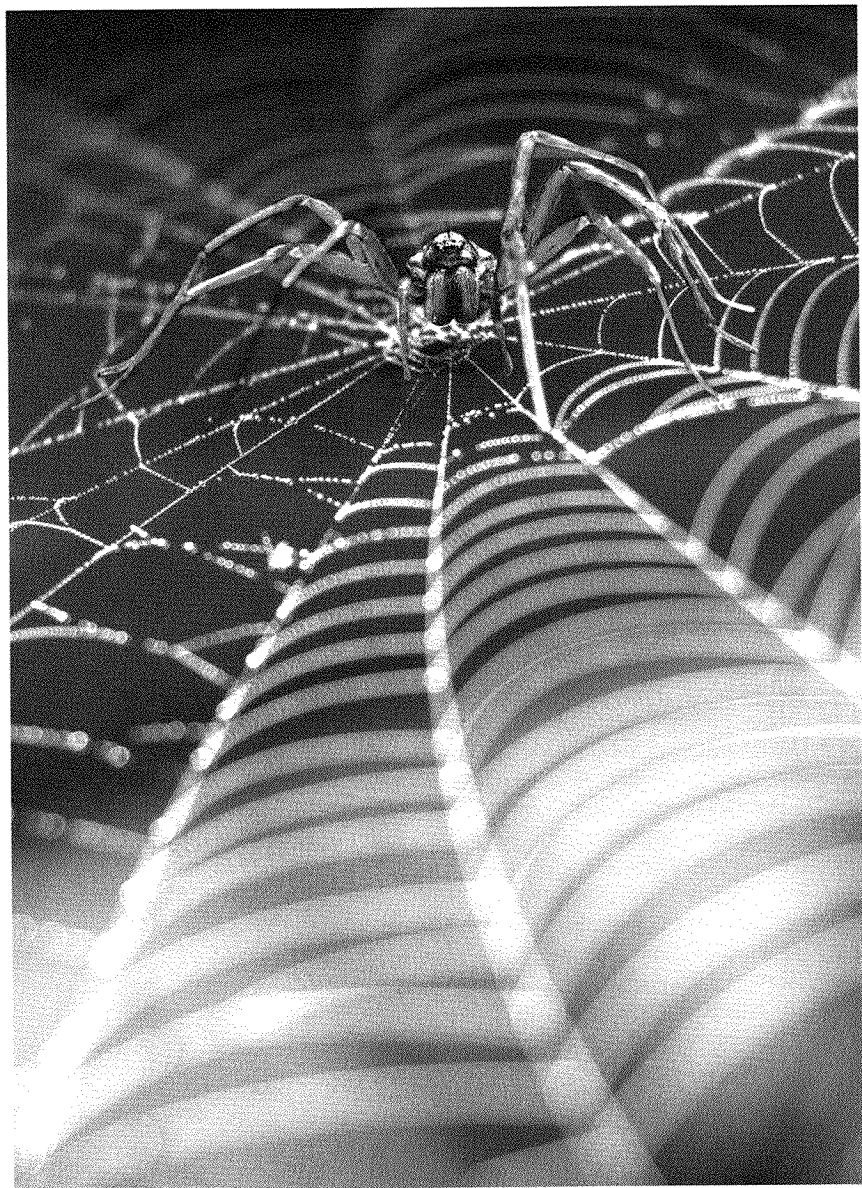

**Orb weaving spider**

# Insects and Spiders

Wherever you hike or camp, whether it is in the mountains, on the edge of the deserts, on a coastal island, or in a prairie, woods, marsh, or park, you are sure to find insects and spiders of many kinds.

To identify insects and spiders you will need a good field guide. In addition, your counselor or another expert can help you. If there is a museum or a zoo nearby, you can probably get help there. If not, rely on books available from your school or public library, or, with your parent's permission, search the internet.

## Collecting Insects

Insect collecting is an inexpensive hobby. Almost all the equipment you need can be made from odds and ends found around the house. If you plan to collect and mount your specimens, you will need a collecting net, a killing jar, a spreading board, and specimen boxes.

---

Make sure you can recognize potentially dangerous spiders native to your area before setting out to collect and/or observe them.

---

## How to Make a Collecting Net

1. Bend a wire clothes hanger into a squared hoop, as shown.
2. Make the bag from fine-mesh fabric, or use a 5-gallon nylon paint strainer (available at most paint stores). Use fishing line to sew the bag to the wire hoop.
3. Use duct tape to fasten the clothes hanger to a wooden dowel or broom handle. Do not make the handle too long or heavy to handle easily.

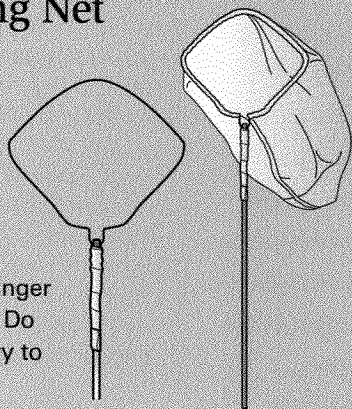



**Killing jar**

Freezing is the safest and cleanest alternative to preparing insects for mounting. Put specimens in a jar in the freezer (with your parent's permission) until they are dead. Soft-bodied insects such as maggots and caterpillars can be killed by placing them directly in rubbing alcohol.

If you prefer, you can use a killing jar to prepare insects for mounting. Wash and dry a wide-mouthed jar, such as a pickle jar. Cut a piece of cotton batting to fit the bottom of the jar, and cut a disk of cardboard or wire screen the same size. Moisten the cotton batting with nail polish remover that contains ethyl acetate, and place it in the bottom of the jar. Place the screen over the batting, and add a crumpled tissue in the jar to absorb moisture and to give the insect something to climb on and hide in.

**Be sure to read the safety precautions on the product you use in the killing jar. Label the jar as "poison," and keep it tightly closed, except when you are putting in or taking out an insect. Do not breathe the fumes; always go outside or to a well-ventilated area to put the fluid in the killing jar, and keep it well away from fire.**

---

Look for spiders in cracks, corners, and other hidden places, such as the back of a closet. Outside, find them in webs stretched between branches of trees and shrubs.

---

For showing your insects, all you need is a cigar box or other similar box lined at the bottom with polystyrene foam, corrugated cardboard, or soft fiberboard. This material will hold the pin on which specimens are mounted. If you use corrugated cardboard, glue two layers together with the ridges running at right angles. Your box will look better with white paper glued on the sides and bottom of the inside.

**If you see fine brown dust on the bottom of a specimen box, you will know that dermestids—or carpet beetles, whose larvae will eat mounted insects—are at work. To keep them out, place moth crystals (paradichlorobenzene) in one corner (preferably in an envelope, too), or put the entire box in a freezer (with your parent's permission) for about a week.**



## The Spreading Board

You will need a spreading board to mount butterflies, dragonflies, and other winged insects. A standard spreading board keeps the insect's body in the center groove so that its wings dry in a slightly raised position. So, when an insect is removed from a spreading board, the wings will droop a bit. Wings dried on a flat surface would droop below the level of the insect's body, detracting from the specimen's appearance.

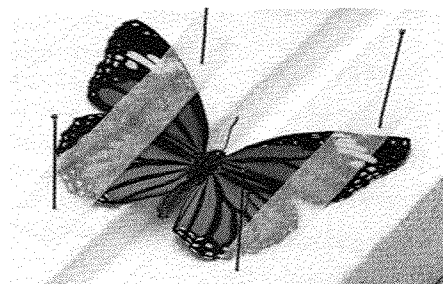

While common straight pins can be used for pinning insects, they are likely to rust or spoil the specimens. Regular insect pins are recommended.

## Insect Pins

You can purchase insect pins from a biological supply company. A local natural history museum, college, high school, or agricultural agent can help you locate the nearest supply company, or see the resources listed in this pamphlet.

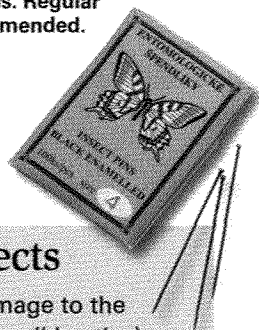

## How to Pin Different Kinds of Insects

Take care in pinning insects to do the least possible damage to the specimens. The tiniest specimens (gnats, mosquitoes, small beetles) are not pinned, but are glued to the tips of small paper points through which the insect pins are thrust.

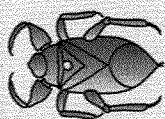

GIANT  
WATER BUG

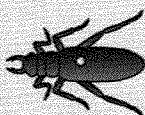

BEETLE

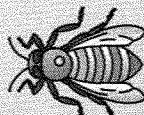

BEE

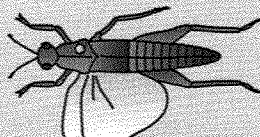

GRASSHOPPER

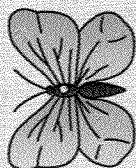

BUTTERFLY

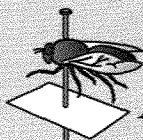

N.Y.: Nassau Co.  
Baldwin  
Aug. 10, 2007  
Scout J. Jones

Record books can be an interesting addition to a collection, but they should not be used in place of complete, accurate labels.

### Labels

Print the labels—called “points”—in permanent ink on small pieces of stiff white paper and place them on the pin below the specimen. One label should show the place and date of capture and the collector’s name. Write the scientific and common names of the insect on the other label. Some enthusiasts also give each specimen a number, which they enter in a record book along with facts of interest, such as the plant on which the insect was found, unusual weather conditions, and color changes after death.

### Raising Insects

Insects lay eggs that, when hatched, bring a new generation of insects into the world. Some eggs hatch into smaller versions of the adult insect. That is, the young closely resemble their parents. They grow through several stages until they are the same size as their parents. Grasshoppers, mantises, and crickets are insects of this type.

Other insects, such as butterflies, moths, dragonflies, and cicadas, lay eggs that hatch into *larvae*, or caterpillars, which in turn spin a cocoon around themselves. They rest in this *pupa* stage until they emerge as adult butterflies or moths. The interesting thing is that in each stage of its life the insect has a different appearance from each other stage. Sometimes it is difficult to identify insects in the larval or pupal stages. If this is the case, you can save the caterpillar or cocoon until it develops into an adult.

With any insects, you can collect egg masses and keep them outdoors or between the screen and window to watch them hatch. But again, it is better not to keep them inside where they will develop too quickly. The artificial heat in your home will cause them to hatch long before there is natural food for them.

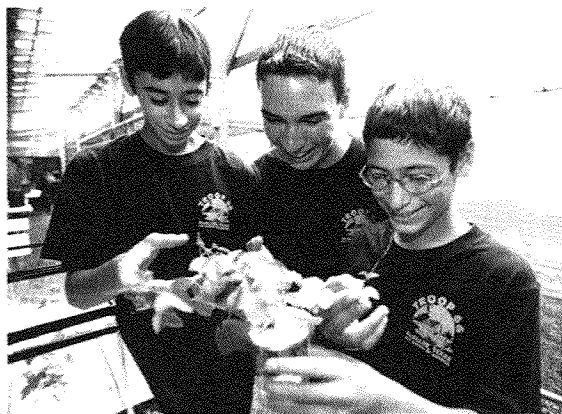

## Becoming a Butterfly

To examine a complete metamorphosis, follow the stages of a monarch butterfly's life. This common orange and black butterfly, *Danaus plexippus*, begins life as a pale green egg on a milkweed leaf. A tiny caterpillar emerges from the egg four or five days after it is deposited. This is the larval stage of the butterfly. The caterpillar immediately eats its eggshell, then consumes milkweed leaves—the only food it will eat during this stage.

For about 12 days, the caterpillar cuts off pieces of milkweed leaves with its strong jaws, molting three or four times in the process. The full-size caterpillar, striped with bands of yellow, black, and green, grows to about 2 inches long.

At the end of its larval stage, the caterpillar begins spinning a silken thread from glands in its mouth, and it attaches one end to a leaf, and the other end to the end of its body. The caterpillar's skin splits and slides off its body while the caterpillar hangs down, revealing the third stage: the pupa or *chrysalis*, a shiny, transparent green. It will hang from the leaf for up to three weeks. Near the end of this stage, the chrysalis turns very dark and the wing pattern of the butterfly will be visible. Finally, the chrysalis will split, and the adult monarch will crawl out. Its wings gradually expand and harden, and its long hollow "tongue" will suck nectar from flowers.

---

Protect your live insects from too much direct sunlight, which can heat them to extremes and cause them to die.

---

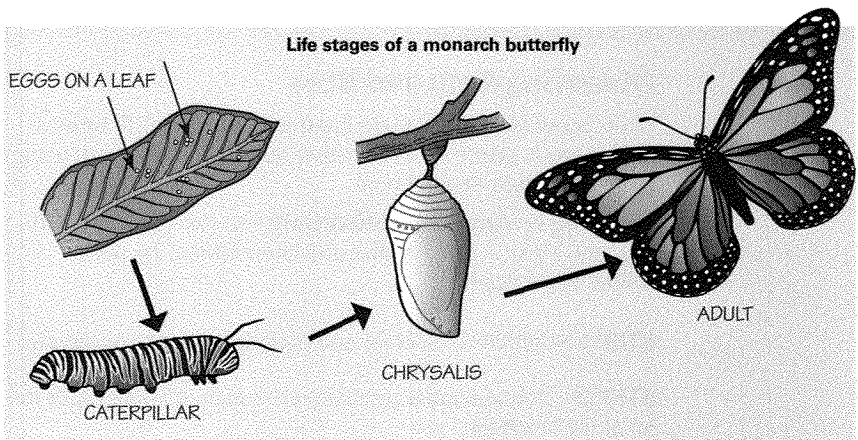



To raise a butterfly at home, put a caterpillar in a covered shoebox and supply it with plenty of leaves from the type of tree on which you found it. You can also enclose the caterpillar and its tree branch in a sleeve of mosquito netting to keep it safe from predators and parasites. If you keep your chrysalis indoors, dampen it occasionally.

## Observing Ants and Bees

These most social insects are interesting to watch. To observe ants at work, create an observation unit since their work naturally takes place underground.

**Preparing an Ant Observation Unit.** Use two glass jars with lids, one about 1 inch smaller and shorter than the other. Follow these steps:

**STEP 1**—Cap the smaller jar and place it inside the larger one.

**STEP 2**—Drill two holes, each about  $\frac{1}{4}$  inch in diameter, in the lid of the larger jar.

**STEP 3**—Put a tight-fitting cork into one of the holes; this will serve as an opening for feeding the colony.

**STEP 4**—Using rubber cement or a glue gun, fasten a screen of fine cloth or wire mesh over the other hole. This construction allows air to get in without letting the habitat dry out rapidly.

**STEP 5**—Find a living, functioning ant colony. Look under large, flat rocks for a nest complete with workers, soldiers, larvae, cocoons, eggs, and winged males and females. Scoop up the living mass, along with some soil, and pour it into the space between the two jars in your observation unit. Fill the space, without packing the dirt, to within an inch of the top, and secure the prepared lid of the larger jar.

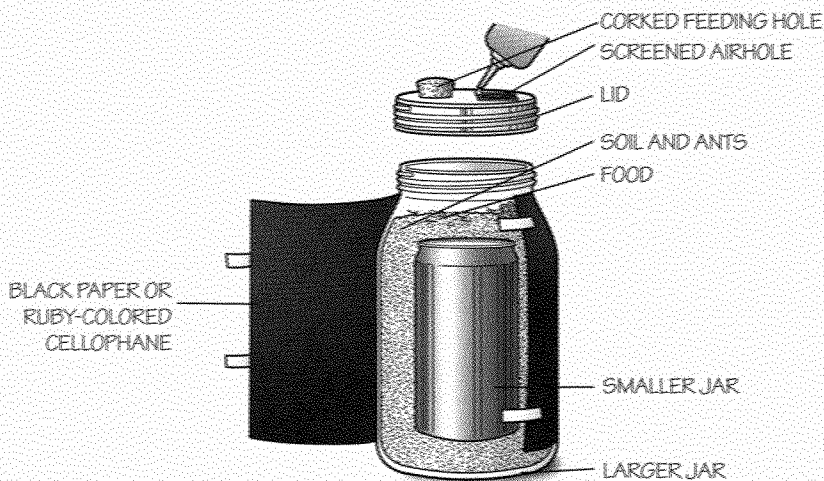

You can now watch your colony thrive as its workers create order from the chaos: they will tunnel in all directions; gather eggs, larvae and cocoons; and organize all the elements into neat piles to be tended by other workers.

To feed the colony, remove the cork and use a medicine dropper to add honey water or sugar water for energy, and drop in bits of hard-boiled egg or dry pet food for protein. Only a small amount of food is required to feed the colony; too much will decompose and contaminate the nest.

Keep the soil damp—but not wet—by adding a few drops of water from time to time.

---

## All About Bees

For more information about honey bees and beekeeping, see the *Gardening merit badge pamphlet*.

---

Watching bees at work may help you gain a new appreciation for the produce we take for granted. Without bees, the critical work of pollination would not be accomplished, and the future of many food sources would be threatened. Bees also pollinate many of the crops and livestock feed our farmers grow.

Though many creatures transfer pollen as they travel about, the honey bee's pollination work is unique in three ways: First, the honey bee practices flower fidelity. That means honey bees visit only one kind of flower on each nectar-foraging trip, so the pollen is transferred to a flower that can use it. Second, the honey bee population is staggering. A full-size colony produces thousands of pollinators each season for quantities unmatched by any other pollinating species. Third, honey bees can be raised in human-constructed hives that can be moved where honey bees are needed.

This enormous population of dedicated pollinators carries out the important work of fertilizing flowering plants. This fertilization enables the pollinated plant to produce seeds from which a new plant may grow. Eventually, these seeds may be contained within the delicious fruit and nutritious vegetables we eat—all thanks to the industrious activity of the honey bee.

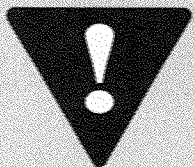

If you want to choose optional requirement 4d(2) and keep a colony of bees through one season, you should first find out whether you are allergic to bee stings. This can be determined by a visit to an allergist or your family physician. If it turns out you are allergic to bee stings, you should choose another option. If you visit a beekeeper, before you do so, be sure your buddy also has been checked by a physician and is not allergic to bee stings.

For help with locating a beekeeper in your state, visit [www.beeculture.com](http://www.beeculture.com) and click on "find a beekeeper near you."

Becoming a beekeeper can command a substantial investment of materials, time, and effort. Discuss your options with your parent, and investigate methods for getting involved in beekeeping that will correspond to your interest level.

### Before You Work With Bees

- It's important to make sure you are not allergic to bee stings by visiting an allergist or your family physician. If you are, do not put yourself at risk; choose a different option. The buddy you choose should also be checked out beforehand and cleared.
- Find an established beekeeper in your area with help from your counselor. Take your buddy with you, and discuss opportunities for working with the beekeeper throughout the season. You may also find a local beekeeper and learn more about beekeeping by visiting [www.beeculture.com](http://www.beeculture.com).
- Wear a bee suit for protection from stings. Some beekeepers keep spare suits on hand, or you can purchase an inexpensive Tyvek coveralls suit from a hardware store. Make sure to wear gloves, boots, and a veil. When you feel safe in your gear, you won't worry about being stung.
- Join a beekeeping club to learn more about this vocation—or avocation.

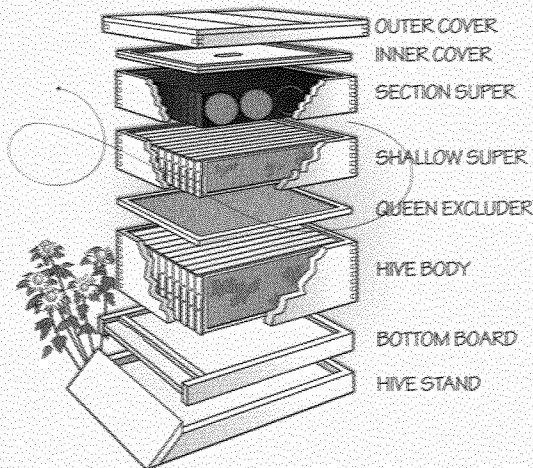

Beekeepers use human-constructed hives with movable frames as required by law. This type of hive serves as a safe home for bees and as a practical, manageable collection station for the beekeeper.

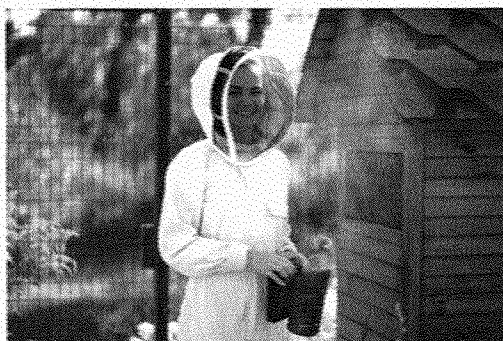

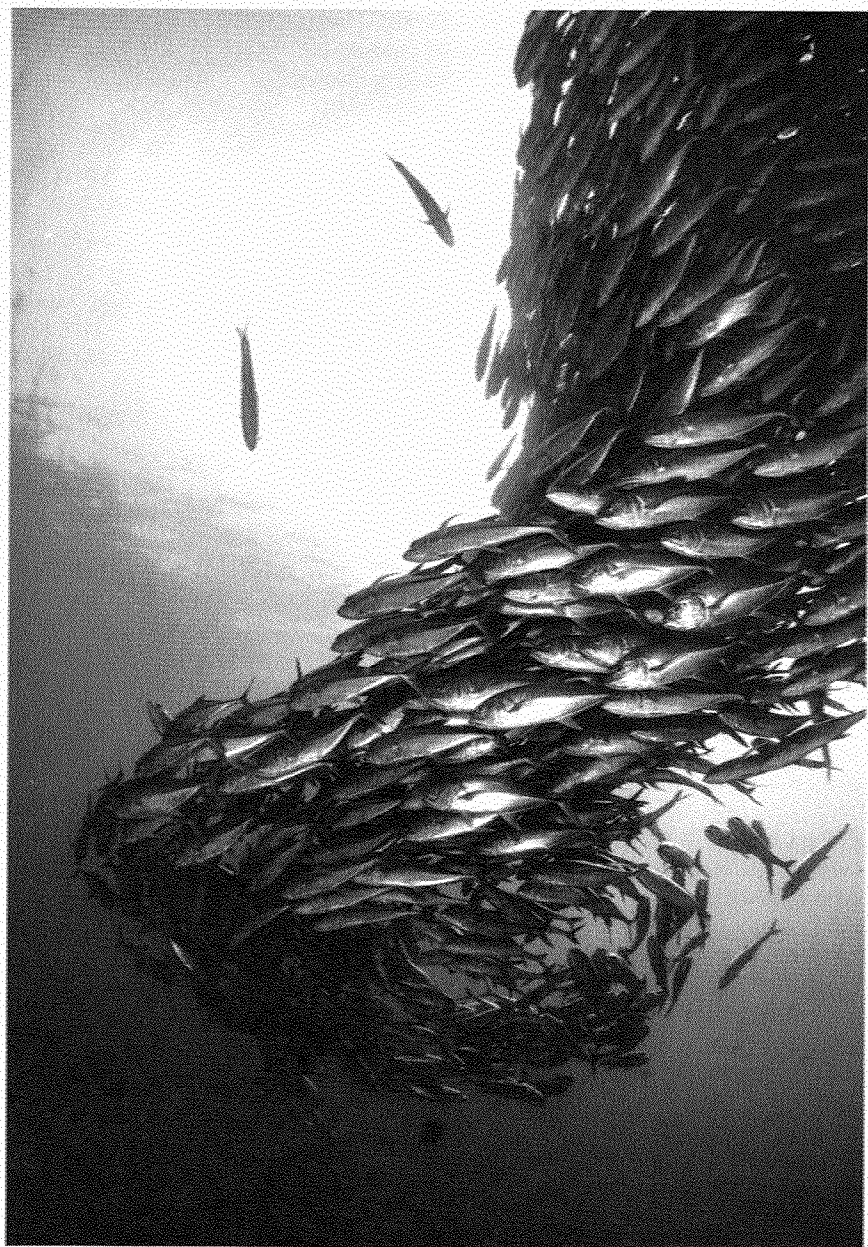



# Fish

Fish can be found just about anywhere there is water. Whether as small as a backyard pond or as large as an ocean, bodies of water are home to fish of all shapes and sizes. Freshwater fish you might catch include the following.

**Black Bass.** Look for largemouth, smallmouth, and spotted bass around brush, fallen trees, weed beds, and rock ledges. Use bait such as leeches, minnows, frogs, jigs, and plastic worms and bugs.

**Panfish.** Rock bass, bluegill (and other sunfishes), and crappie are all in this category. Rock bass are brassy-colored with rows of black scales. They will strike at almost any kind of live bait or lure and can be found around bridge piers, docks, boulders, and weed beds. Bluegill are purplish with a distinctive dark blue patch on the gill cover. Use small hooks to catch them. Crappie are larger than bluegill, are silvery with black markings, and will strike at small spinners and lures.

**Catfish.** These are smooth-skinned, scaleless fish found in most of the United States, from clear, icy waters in the North to warm, muddy waters in the South. They are relatively easy to catch with all kinds of bait. Look for them beneath undercut banks and logjams, and in deep holes and channels.

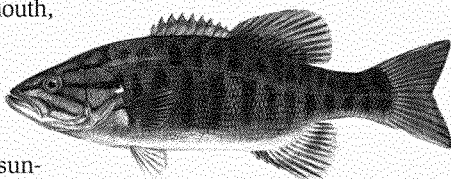

Smallmouth bass

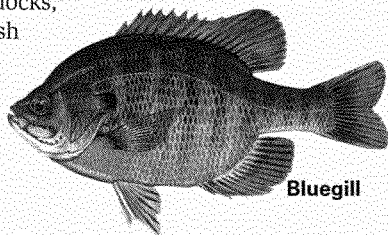

Bluegill

**Stream Trout.** These are sleek and colorful fish. Brook trout are dark with light spots and light edges to their lower fins, rainbow trout have silvery sides with small dark spots, and brown trout are yellowish-tan with brown and red spots that appear surrounded by a halo. Trout will bite all types of flies, small spoons, and spinners, as well as worms, minnows, and insects.

If you live near coastal areas, you can fish from piers or the surf, or troll or cast from outboard craft. Some saltwater fish you might catch include California yellowtail, drum, pompano, redfish, salmon, snapper, and spotted sea trout.

---

*Catch and release* is an important conservation measure practiced by anglers. In some areas, catch and release is the law. See the *Fishing and Fly-Fishing* merit badge pamphlets for more information on the sport.

---

Finding a place to catch fish in freshwater or salt water should be easy. However, catching fish might take a little skill. Here are a few tips to help you land a few.

- Look for them where the bank meets the water, where a sandbar drops off, and where two currents meet.
- Look for them around weed beds; underneath overhanging trees, brush, and docks; and where rocks jut out from shore.
- Rushing water carries food and lots of oxygen, both of which fish enjoy. Look for them in pools under waterfalls.

Prepare before you go. Assemble the right equipment—tackle, bait, and clothing—for the kind of fishing you plan to do. Obey all fish and game laws, be aware of limits and seasons, and obtain all required licenses. For safety, let someone know your travel plan. Take a friend, and have fun!

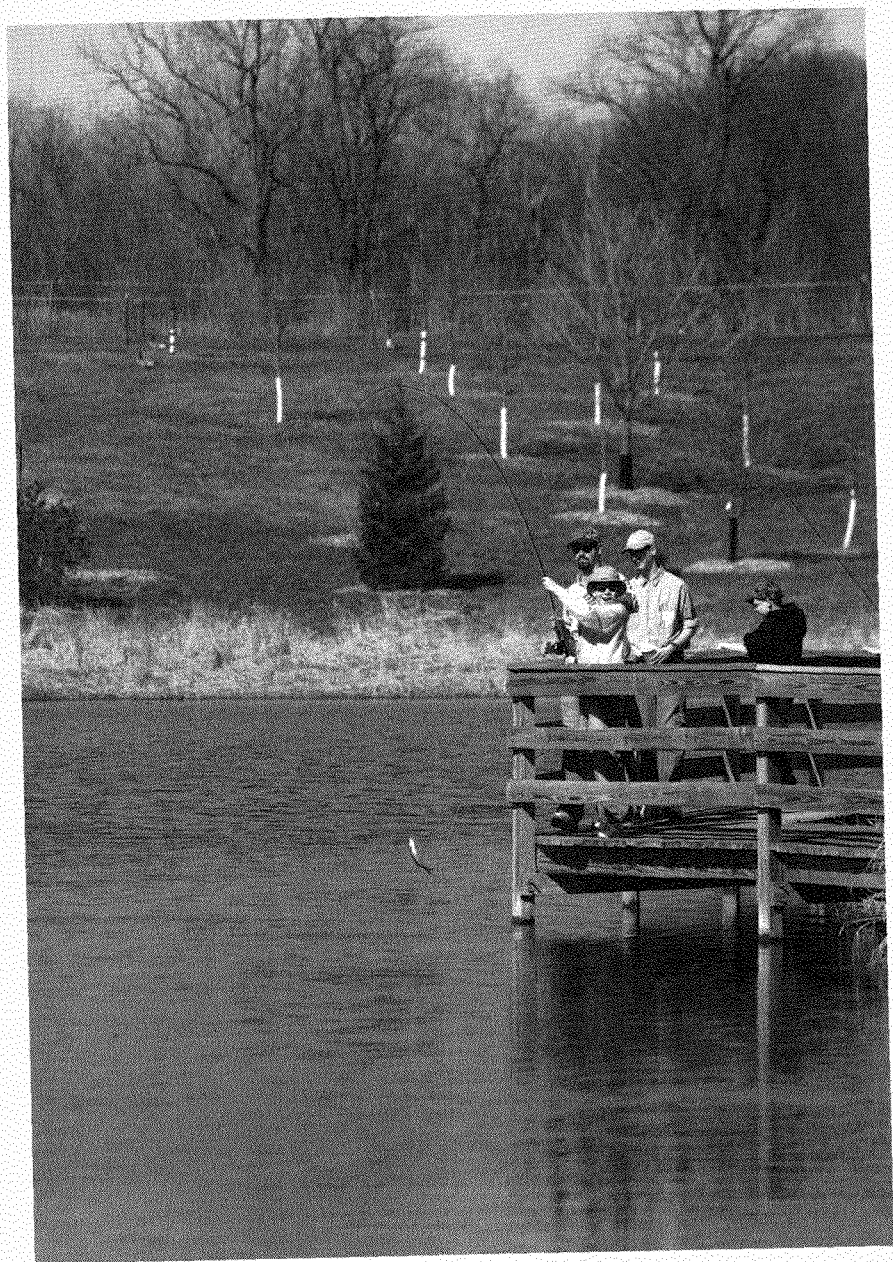

## Mollusks and Crustaceans

Collecting and identifying mollusks (snails, slugs, clams, mussels, oysters, whelks) and crustaceans (crabs, lobsters, crayfish, shrimp) will be easier if you live along coastal areas. However, many of them do live in freshwater and on land.

Crustaceans can be caught with nets in shallow water or with traps in deeper water. Dip nets and traps can be found at hardware stores and fishing tackle shops. Local anglers and sports enthusiasts may know where best to collect crabs and other crustaceans.

Crabbing with a piece of firm meat tied to a string is both fun and challenging. Crabs grasp the meat and hold on to the bait while the string is slowly pulled toward the surface of the water. With a dip net already in the water, you quickly pull the net up under the crab before the crab drops the bait.

---

Dip nets and quick hands are the best way to collect crayfish and shrimp in freshwater.

---

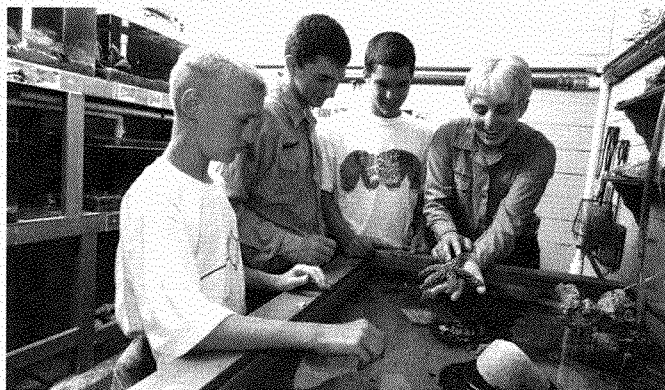

Like clams, mollusks usually are in the sand or mud and can be dug at low tide with a rake or shovel. Oysters and mussels can be collected from the rocks and hard surfaces along the shore between high and low watermarks. Shells of many mollusks that die wash up on shore and are easy to collect after storms. Land snails, often called slugs, can be found in gardens and under decaying leaf litter. In freshwater, water snails can be found attached to rocks on the stream bottom, while mussels are usually partially submerged in bottom sediments.

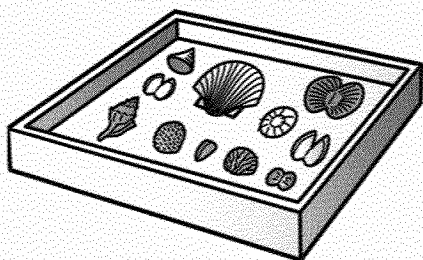

SHELL COLLECTING TRAY

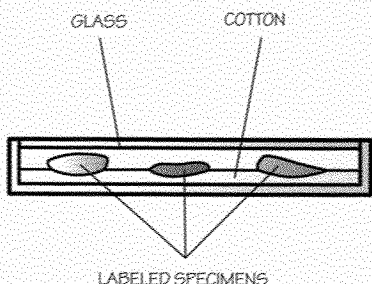

LABELED SPECIMENS

To date, no marine mollusks are endangered, but this is not the case for some freshwater mussels, snails, and crayfish. Make sure you are aware if there are any restrictions on collecting these animals.

## Mounting Shells

Mount shells in flat trays or boxes with a glass top that keeps the dust away. Boxes with compartments or plastic jewelry boxes help to keep the shells from knocking together and breaking. Because thin shells are easily broken, it might also be a good idea to cushion them with tissue paper.

Shells may be labeled in much the same way as insects. The label should identify the species and can also list such information as the date and place it was found, as well as any color features.

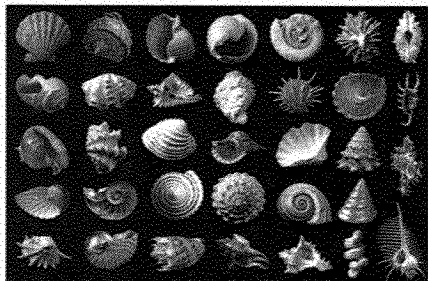



# Plants

Identifying 15 species of wild plants should be an easy task, wherever you live. There are few wildlife communities that do not contain at least 15 different plants. If you can't find them within your wildlife community, try looking along the edges. Try identifying the plants you see on your way to school, in the city park, in Scout camp, or even on a farm or in your backyard. First, though, you should know something of the five major groupings of the plant kingdom.

**Slime Molds.** These are the lowest form of plants and, as the name implies, they are the slimy mosses you find on wet rocks or rotten logs.

**Leafless Plants.** Plants in this group include bacteria, algae, and fungi (toadstools or mushrooms). Bacteria and fungi cannot make food from sunlight like other plants can because they lack chlorophyll. Instead, they depend on other plants and animals for nourishment. For example, mushrooms you see growing on a rotting tree draw nutrients from the tree. Most algae contain chlorophyll and process sunlight to make food.



---

Some varieties of mushrooms and berries are extremely poisonous. Do not touch them unless you know the species is safe.

---



**Ferns.** These plants have true roots, but do not have flowers or seeds.

**Mosslike Plants.** In this group are mosses and liverworts. Most mosses have leaves, while most liverworts do not. These plants have no true roots, nor do they have flowers or seeds.

**Seed Plants.** This group includes all the flowering plants, from grasses to shrubs and trees. They usually make seeds to reproduce, but sometimes they throw out runners. This might be

the group that will interest you most because the plants in this group are easiest to identify.

---

Poison Control  
Center  
800-222-1222

---

**Poisonous Plants.** Some plants, including poison ivy, poison oak, and poison sumac, contain oily sap that can cause a rash or illness if it comes into contact with skin. Reactions can include blisters, swelling, itching, burning, headache, and even fever—symptoms that can occur after the sap is on skin for 10 to 20 minutes.

If you think you have touched a poisonous plant, wash the exposed area well with soap and water, wipe with rubbing alcohol, and apply calamine lotion. A severe reaction, contact with genital areas, or ingestion requires immediate medical attention. Sap can also adhere to clothing, so change out of the affected garments immediately, and keep them separate from other clothing. Wash the garments separately as well when you get home.

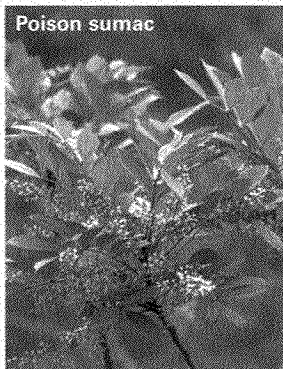
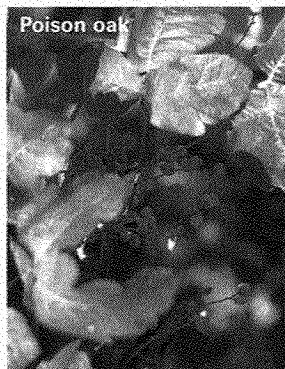



## Collecting Leaves

Collecting leaves is simple, if you remember three things: avoid poisonous plants; collect specimens as perfect (without insect holes) as you can; and be sure to collect the entire leaf. Some plants, like the hickories, sumacs, locusts, and ashes, have compound leaves. That is, each leaf has several leaflets. If you do not collect the entire leaf, the specimen might be misleading and your collection will not be satisfactory.

The next step is to press the leaves and dry them. Using old newspapers, make a press such as the one shown. Place the leaves in it carefully, so they dry flat and are not creased. When the leaves are thoroughly dry, mount them in a notebook using double-sided tape to hold them to the page. Label each with the name of the specimen, the date, and the place it was collected.

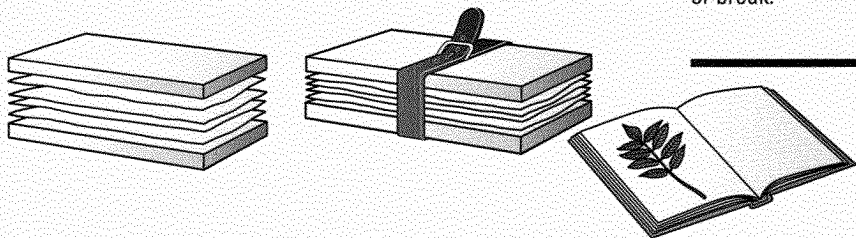

A homemade press is suitable to dry and flatten leaves before mounting. After mounting, keep the leaves under pressure so they will not curl or break.

## Collecting Seeds

Seeds will be easiest to find from midsummer to late fall—from the time annual weeds start to produce seed to the time trees produce acorns, nuts, and other seeds. But if you look under pines or spruces in the winter you might find seeds that birds or mammals have spread as they break cones apart. You will certainly find cones, and it is easy to dry them out and get the seeds yourself.

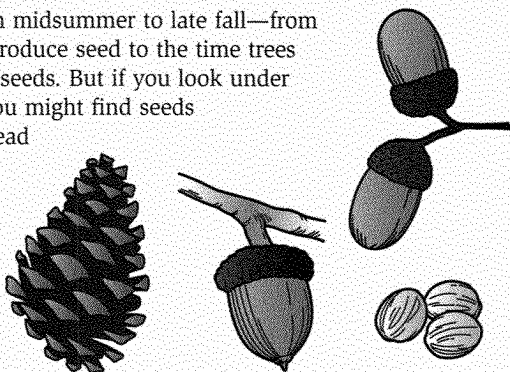

Seeds you collect can be stored in small plastic sandwich bags, plastic boxes, or bottles. Store larger seeds in boxes or jars. Write the name, date, and place of collection on a small piece of paper and paste it to the envelope, bottle, or jar.

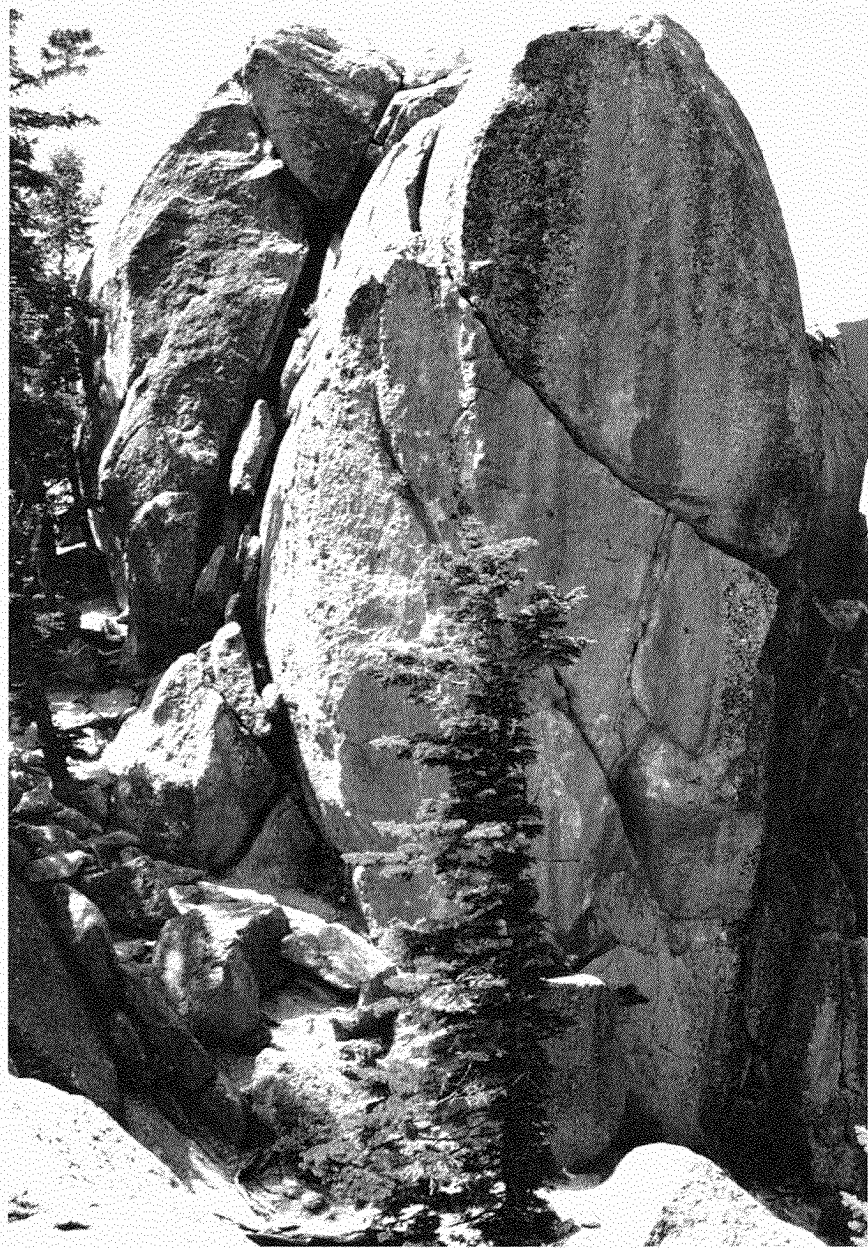

# Soil and Rocks

There are many kinds of rock and rock formations in this country. Let's look at rocks according to the way they formed. There are three general groups of rocks: igneous, sedimentary, and metamorphic.

## Rock Types

### Igneous Rocks

Most of us have not actually seen a volcano erupting. But we know that when one does erupt, lava pours forth. Lava is molten rock—that is, rock that has been heated miles underground until it is liquid. As this lava pours out, the air cools it, and it hardens into igneous rock. One of the more common igneous rocks is granite, which forms beneath the Earth and is forced to the surface by the compression of land masses.

Igneous rocks can contain many varieties of minerals, including quartz, feldspar, and a group of minerals containing iron and magnesium. Igneous rocks containing quartz and feldspar are usually light in weight and color, while those containing iron are heavier and darker.





### Sedimentary Rocks

When bits of rock and soil are washed into an ocean or lake, they settle to the bottom, layer upon layer. Finally, by pressure from the water above, these layers of *sediment* become pressed together into solid rock. Sandstone is a type of sedimentary rock formed by this type of pressure on sand. Shale is a sedimentary rock formed when layers of clay are pressed into solid rock.

Some sedimentary rocks contain shells from shellfish, skeletons of other water animals, and the remains of water plants. Limestone and chalk are sedimentary rocks formed from animal (shellfish) remains, while coal is sedimentary rock formed by pressure on plant remains.

Sedimentary rock also forms when rock is dissolved in liquid, such as flowing water, and hardened again. Certain iron ores, flint, gypsum, and common salt are examples of sedimentary rock formed in this way.

### Metamorphic Rocks

Pressure and heat are two of these forces that help to form metamorphic rock. After igneous rock is broken down and sedimentary rock is formed, heat and pressure can change them into metamorphic rock.

Heat and pressure might change the texture of the original rock, or new minerals might be added or formed from chemi-

cals extracted from existing rocks. In some cases, more than one of these processes occurs in the formation of the new rock.

Granite is an igneous rock, but under heat and pressure it can change to a metamorphic rock called gneiss. Shale, a sedimentary rock, can change into slate. Sandstone, also a sedimentary rock, can change into quartzite. Limestone can change into marble.

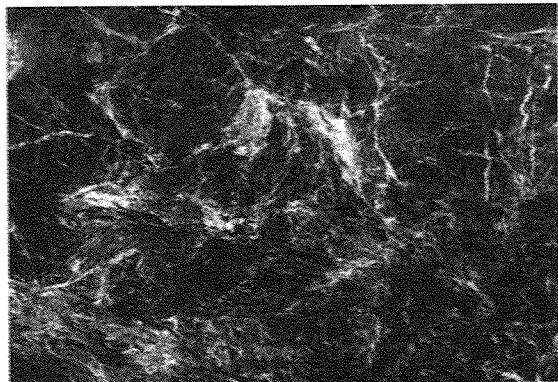

Marble

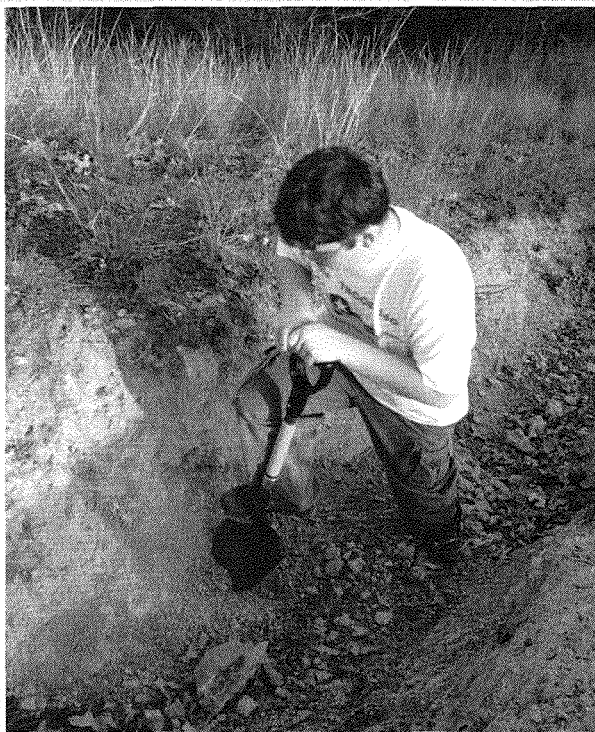

---

Different degrees of heat and pressure bring about different changes. Shale, which will change to slate under heat and pressure, might become an even harder rock called schist when exposed to extreme heat and pressure.

---

## Soil Profiles

The best way to find out about soil is to dig deep enough to see a soil profile—the arrangement of layers beneath the surface to a depth of 3 feet or more. Dig these profiles, look at a road cut, or cut away a bank to expose profiles in different places, and see if you can find different kinds of soil. For example, dig a profile in a wooded area and in an open field; in a hedgerow and in a field; in a cultivated field and in a pasture. Be sure to replace the soil once you have finished.

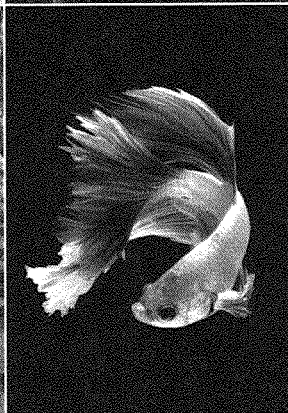
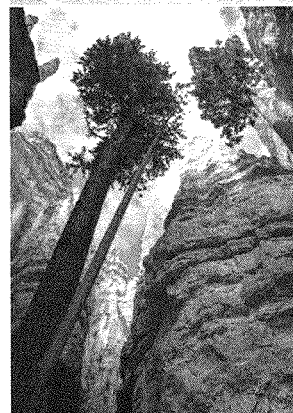
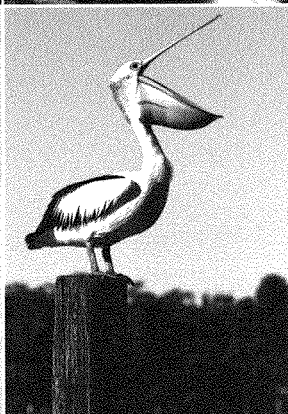
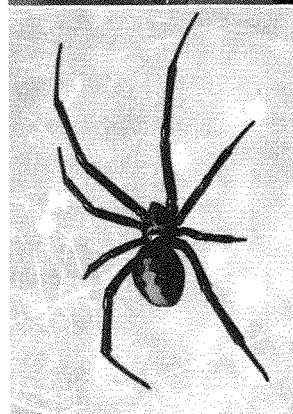
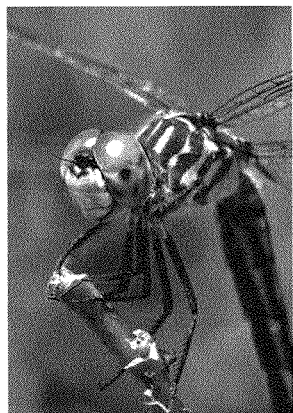

# Nature Resources

## Scouting Literature

*Conservation Handbook; Fieldbook; The Principles of Leave No Trace; Mammals pocket guide; Reptiles and Amphibians pocket guide; Eastern Backyard Birds pocket guide; Western Backyard Birds pocket guide; Bugs and Slugs pocket guide; Edible Wild Plants pocket guide; Roadside Wildflowers pocket guide; Freshwater Fishes pocket guide; Trees pocket guide; Geology pocket guide; Animal Science, Backpacking, Bird Study, Camping, Canoeing, Environmental Science, Fish and Wildlife Management, Fishing, Fly-Fishing, Forestry, Gardening, Geology, Hiking, Insect Study, Mammal Study, Oceanography, Photography, Plant Science, Reptile and Amphibian Study, Soil and Water Conservation, Sustainability, and Wilderness Survival merit badge pamphlets*

With your parent's permission, visit the Boy Scouts of America's official retail website, [www.scoutshop.org](http://www.scoutshop.org), for a complete listing of all merit badge pamphlets and other helpful Scouting materials and supplies.

## Books

- Arnett, Ross H. *American Insects: A Handbook of the Insects of America North of Mexico*, 2nd ed. CRC Press, 2000.
- Behler, John. *Reptiles (The National Audubon Society First Field Guide)*. Scholastic Trade, 1999.
- Bland, Roger G., and H.E. Jaques. *How to Know the Insects*, 3rd ed. Waveland Press, 2010.
- Cassie, Brian. *Amphibians (The National Audubon Society First Field Guide)*. Scholastic Trade, 1999.
- Dance, S. Peter. *Shells*, 2nd ed. DK Adult, 2002.
- Dillon, Mike. *The Great Birdhouse Book*. Sterling Publications, 2000.
- Elpel, Thomas J. *Botany in a Day: The Patterns Method of Plant Identification*, 6th ed. Hops Press, 2013.
- Fichter, George S., and Phil Francis. *Fishing: A Guide to Fresh and Salt-Water Fishing*. St. Martin's Press, 2013.
- Griggs, Jack, ed. *All the Birds of North America: American Bird Conservancy's Field Guide*. Harper Collins, 2002.

- Harris, James G., and Melinda Woolf Harris. *Plant Identification Terminology: An Illustrated Glossary*, 2nd. ed. Spring Lake Publishers, 2001.
- Izaak Walton League of America. *Guide to Aquatic Insects and Crustaceans*. Stackpole Books, 2006.
- Levine, Lynn, and Martha Mitchell. *Mammal Tracks and Scat: Life-Size Tracking Guide*. Heartwood Press, 2008.
- MacDonald, David, ed. *The Encyclopedia of Mammals*. Facts on File, 2006.
- Rehder, Harald A. *National Audubon Society Field Guide to North American Seashells*. Knopf, 1981.
- Tarback, Edward J., et al. *Earth: An Introduction to Physical Geology*, 11th ed. Pearson, 2013.
- Wernert, Susan J., ed. *Reader's Digest North American Wildlife*. Reader's Digest, 2008.

### **Organizations, Periodicals, and Websites**

#### **Acorn Naturalists**

Website: [www.acornnaturalists.com](http://www.acornnaturalists.com)

#### **American Birding Association**

Toll-free telephone: 800-850-2473

Website: [www.aba.org](http://www.aba.org)

#### **American Museum of Natural History**

Central Park West at 79th Street

New York, NY 10024-5192

Website: [www.amnh.org](http://www.amnh.org)

#### **Bee Culture Magazine**

Website: [www.beeculture.com](http://www.beeculture.com)

#### **Discover Magazine**

Website: [www.discovermagazine.com](http://www.discovermagazine.com)

#### **National Audubon Society**

Website: [www.audubon.org](http://www.audubon.org)

#### **National Fish and Wildlife Foundation**

1133 15th St. NW, Suite 1000

Washington, DC 20005

Website: [www.nfwf.org](http://www.nfwf.org)

#### **National Geographic Society**

Website:

[www.nationalgeographic.com](http://www.nationalgeographic.com)

#### **National Park Service**

Website: [www.nps.gov](http://www.nps.gov)

#### **U.S. Fish and Wildlife Service**

Website: [www.fws.gov](http://www.fws.gov)

#### **World Wildlife Fund**

Website: [www.worldwildlife.org](http://www.worldwildlife.org)

### **Recordings of Bird Calls**

Peterson, Roger Tory. *Field Guide to Bird Songs: Eastern/Central North America*. 1990. CD with 250 species.

Walton, Richard, and Robert Lawson. *Birding by Ear*. 1989.

———. *Birding by Ear: Western*. 1990.

———. *More Birding by Ear: Eastern and Central*. 1994.

### **Biological Supply Companies**

#### **BioQuip Products**

Telephone: 310-667-8800

Website: [www.bioquip.com](http://www.bioquip.com)

#### **Carolina Biological Supply Company**

Website: [www.carolina.com](http://www.carolina.com)



## Acknowledgments

The Boy Scouts of America is grateful to the men and women serving on the National Merit Badge Subcommittee for the improvements made in updating this pamphlet.

The Boy Scouts of America thanks Gary Stolz, Ph.D., U.S. Fish and Wildlife Service, for his involvement with revisions to the *Nature* merit badge pamphlet. We are grateful for his thorough review and input.

## Photo and Illustration Credits

- Allen Bridgman, SCDNR, Bugwood.org, courtesy—page 42 (*copperhead*, *both*)
- David Cappaert, Michigan State University, Bugwood.org, courtesy—page 43
- Commonwealth Scientific and Industrial Organization/David McClenaghan, courtesy—page 41 (*giant toad*)
- Gardensafari.net/H. Arentsen, courtesy—page 37
- James Henderson, Gulf South Research Corporation, Bugwood.org, courtesy—page 42 (*rattlesnake on right*)
- International Game Fish Association; artist Duane Raver—page 55 (*both*)
- Jeffrey J. Jackson, University of Georgia, Bugwood.org, courtesy—page 42 (*coral snake*)
- Kitty Kohout, The Morton Arboretum, Lisle, Illinois—page 62 (*poison sumac*)
- National Oceanic and Atmospheric Administration, courtesy—page 38 (*white-footed mouse*)
- National Oceanic and Atmospheric Administration/Capt. Budd Christman, NOAA Corps, courtesy—page 38 (*walrus*)
- Shutterstock.com—cover (*snake*, ©Benny Marty; *starfish*, ©Preto Perola; *salmon*, ©martiapunts; *praying mantis*, ©JIANG HONGYAN; *hand and magnifying glass*, ©Christian Musat; *wolf*, ©Holly Kuchera); pages 4 (©Tom Pavlasek), 5 (©Art Wittingen), 6 (©Angel Simon), 9 (©konmesa), 10 (©Maridav), 16 (©Robert O Hull), 18 (©Alius Imago), 19 (*red fox*, ©olga\_gl), 26 (*girl with binoculars*, ©savitskaya iryna), 36 (©Bildagentur Zoonar GmbH), 44 (©Amy Johansson), 53 (*young beekeeper*, ©Kukota), 54 (©Leonardo Gonzalez), 59 (©Fedorov Oleksiy), and 68 (*dragonfly*, ©Rob Hainer; *lemur*, ©tolmachev; *honey bee*, ©Klagyivik Victor; *black widow*, ©Peter Waters; *pelican*, ©G Tipene; *chameleon*, ©fivespots; *pine trees*, ©Circumnavigation; *betta fish*, ©bluehand; *toadstools*, ©Arve Bettum)
- U.S. Department of Agriculture/Bob Nichols, courtesy—page 13
- U.S. Fish and Wildlife Service, courtesy—pages 29 (*woodpecker*) and 30
- U.S. Fish and Wildlife Service/Steve Maslowski, courtesy—page 19 (*prairie warbler*)
- U.S. Fish and Wildlife Service/Pete Pattavina, courtesy—page 42 (*cottonmouth on right*)
- U.S. Fish and Wildlife Service/Gary M. Stolz, courtesy—page 42 (*turtle*, *rattlesnake on left*)

Wikipedia.org, courtesy—pages 22,  
27–28 (*all*), 29 (*American robin*),  
and 33 (*barn swallow nest*)

Wikipedia.org and the Public Health  
Image Library, a Division of the Centers  
for Disease Control, courtesy—page 42  
(*cottonmouth on left*)

Wikipedia.org/Whit Welles, courtesy—  
page 12

All other photos and illustrations are  
the property of or are protected by the  
Boy Scouts of America.

Dan Bryant—page 10 (*canoe*)

Gene Daniels—page 20

John McDearmon—pages 7, 15, 24, 31  
(*plans*), 33 (*mourning dove nest bas-  
ket and plans*), 34 (*all*), 45 (*both*),  
47 (*all illustrations*), 49 (*all illustra-  
tions*), 51, 53 (*hive*), 59 (*all illustra-  
tions*), and 63 (*all illustrations*)

Brian Payne—pages 8, 10 (*hikers*), and  
38 (*elk*)

Randy Piland—page 62 (*poison oak*)

Steve Seeger—page 60

Julie Zickefoose—pages 31  
(*nest box*) and 35

## MERIT BADGE LIBRARY

Though intended as an aid to youth in Scouts BSA, and qualified Venturers and Sea Scouts in meeting merit badge requirements, these pamphlets are of general interest and are made available by many schools and public libraries. The latest revision date of each pamphlet might not correspond with the copyright date shown below, because this list is corrected only once a year, in January. Any number of merit badge pamphlets may be revised throughout the year; others are simply reprinted until a revision becomes necessary.

If a Scout has already started working on a merit badge when a new edition for that pamphlet is introduced, *they may continue to use the same merit badge pamphlet to earn the badge and fulfill the requirements therein.* In other words, the Scout need not start over again with the new pamphlet and possibly revised requirements.

Merit Badge Pamphlet	Year	Merit Badge Pamphlet	Year	Merit Badge Pamphlet	Year
American Business	2019	Family Life	2016	Plant Science	2018
American Cultures	2013	Farm Mechanics	2017	Plumbing	2012
American Heritage	2013	Fingerprinting	2014	Pottery	2008
American Labor	2018	Fire Safety	2019	Programming	2019
Animal Science	2014	First Aid	2019	Public Health	2017
Animation	2015	Fish and Wildlife Management	2014	Public Speaking	2013
Archaeology	2017	Fishing	2013	Pulp and Paper	2019
Archery	2019	Fly-Fishing	2014	Radio	2017
Architecture and Landscape Architecture	2014	Forestry	2019	Railroading	2019
Art	2013	Game Design	2019	Reading	2013
Astronomy	2019	Gardening	2013	Reptile and Amphibian Study	2018
Athletics	2019	Genealogy	2013	Rifle Shooting	2012
Automotive Maintenance	2017	Geocaching	2019	Robotics	2016
Aviation	2014	Geology	2016	Rowing	2019
Backpacking	2016	Golf	2019	Safety	2016
Basketry	2017	Graphic Arts	2013	Salesmanship	2013
Bird Study	2019	Hiking	2016	Scholarship	2014
Bugling (see Music)		Home Repairs	2012	Scouting Heritage	2019
Camping	2019	Horsemanship	2013	Scuba Diving	2009
Canoeing	2019	Indian Lore	2008	Sculpture	2019
Chemistry	2018	Insect Study	2019	Search and Rescue	2018
Chess	2016	Inventing	2016	Shotgun Shooting	2013
Citizenship in the Community	2015	Journalism	2019	Signs, Signals, and Codes	2015
Citizenship in the Nation	2019	Kayaking	2019	Skating	2015
Citizenship in the World	2015	Landscape Architecture (see Architecture)		Small-Boat Sailing	2019
Climbing	2019	Law	2019	Snow Sports	2019
Coin Collecting	2017	Leatherwork	2017	Soil and Water Conservation	2019
Collections	2013	Lifesaving	2019	Space Exploration	2016
Communication	2013	Mammal Study	2014	Sports	2012
Composite Materials	2012	Medicine	2012	Stamp Collecting	2013
Cooking	2014	Metalwork	2012	Surveying	2004
Crime Prevention	2012	Mining in Society	2014	Sustainability	2013
Cycling	2017	Model Design and Building	2010	Swimming	2019
Dentistry	2016	Motorboating	2019	Textile	2019
Digital Technology	2014	Moviemaking	2013	Theater	2019
Disabilities Awareness	2016	Music and Bugling	2013	Traffic Safety	2016
Dog Care	2016	Nature	2014	Truck Transportation	2013
Drafting	2013	Nuclear Science	2019	Veterinary Medicine	2015
Electricity	2013	Oceanography	2012	Water Sports	2019
Electronics	2014	Orienteering	2016	Weather	2019
Emergency Preparedness	2019	Painting	2016	Welding	2019
Energy	2014	Personal Fitness	2019	Whitewater	2019
Engineering	2016	Personal Management	2019	Wilderness Survival	2019
Entrepreneurship	2013	Pets	2013	Wood Carving	2016
Environmental Science	2015	Photography	2019	Woodwork	2019
Exploration	2016	Pioneering	2016		

## BOY SCOUTS OF AMERICA • SUPPLY GROUP

### NATIONAL DISTRIBUTION CENTER

2109 Westinghouse Boulevard  
P.O. Box 7143  
Charlotte, NC 28241-7143

To place an order,  
call customer service  
toll-free 800-323-0736  
or go to  
[www.scoutshop.org](http://www.scoutshop.org)



EAGLE SCOUT



THE SUMMIT



FLORIDA SEA BASE



PHILMONT SCOUT RANCH



NORTHERN TIER



ON THE ROAD TO  
HIGH ADVENTURE

THE SUPPLY GROUP IS  
READY TO BE A PARTNER  
ON YOUR TRAIL TO  
EAGLE THROUGH HIGH  
ADVENTURE. THE  
ADVENTURE IS YOURS.  
AND WE ARE READY  
WITH THE GEAR YOU  
WILL NEED. YOU CAN  
DEPEND ON THE LATEST  
IN LIGHTWEIGHT,  
DURABLE, QUALITY  
GEAR THAT WILL  
MEET AND SURPASS  
YOUR TOUGHEST  
REQUIREMENTS.



[WWW.SCOUTSHOP.ORG](http://WWW.SCOUTSHOP.ORG)

SKU 655195



35922

2020 Printin



Certified Sourcing  
[www.sfi-program.org](http://www.sfi-program.org)  
SFI-00338