

MERIT BADGE SERIES

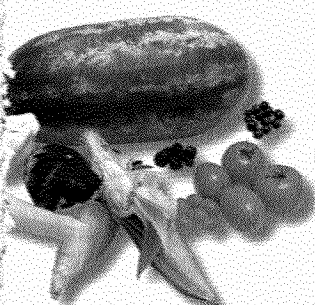

# GARDENING

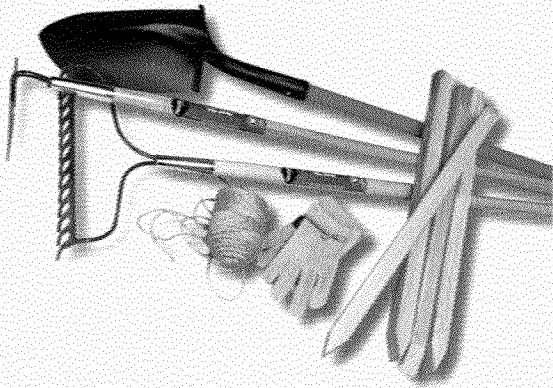

BOY SCOUTS OF AMERICA®



STEM-Based



## How to Use This Pamphlet

The secret to successfully earning a merit badge is for you to use both the pamphlet and the suggestions of your counselor.

Your counselor can be as important to you as a coach is to an athlete. Use all of the resources your counselor can make available to you. This may be the best chance you will have to learn about this particular subject. Make it count.

If you or your counselor feels that any information in this pamphlet is incorrect, please let us know. Please state your source of information.

Merit badge pamphlets are reprinted annually and requirements updated regularly. Your suggestions for improvement are welcome.

## Who Pays for This Pamphlet?

This merit badge pamphlet is one in a series of more than 100 covering all kinds of hobby and career subjects. It is made available for you to buy as a service of the national and local councils, Boy Scouts of America. The costs of the development, writing, and editing of the merit badge pamphlets are paid for by the Boy Scouts of America in order to bring you the best book at a reasonable price.

Send comments along with a brief statement about yourself to  
Pilots and Program Development, S272

Boy Scouts of America • 1325 West Walnut Hill Lane • Irving, TX 75038  
If you prefer, you may send your comments to [merit.badge@Scouting.org](mailto:merit.badge@Scouting.org).

BOY SCOUTS OF AMERICA  
MERIT BADGE SERIES

# GARDENING



*"Enhancing our youths' competitive edge through merit badges"*



BOY SCOUTS OF AMERICA®

# Note to the Counselor

Before any Scouts choose optional requirement 8e, they should first find out whether they are allergic to bee stings. This can be determined by a visit to an allergist or family physician. If it turns out Scouts are allergic to bee stings, they should choose another option. If Scouts visit a beekeeper with their buddy, that buddy also should be checked for allergies by a physician before the visitation.

Prior to counseling Scouts, Gardening merit badge counselors are strongly encouraged to become familiar with the *Guide to Safe Scouting*, a helpful planning tool for all Scouting volunteers. This resource provides an overview of Scouting policies and procedures rather than comprehensive, standalone documentation. For some items, the policy statements are complete. However, unit leaders are expected to review the additional reference materials cited (such as the *Guide to Safe Scouting* and the *First Aid* merit badge pamphlet) prior to conducting certain activities. Counselors can access the *Guide to Safe Scouting* online by visiting [www.scouting.org/health-and-safety/gss/](http://www.scouting.org/health-and-safety/gss/).

To help keep participants safe during Scouting activities, the National Council has an established set of procedures called the "Sweet Sixteen of BSA Safety." In an effort to assist Gardening merit badge counselors, the following considerations provide additional guidance of special interest to them.

**Qualified Supervision.** The Gardening merit badge counselor should have knowledge of the proper use of gardening tools and pesticides, and applicable local and state USDA regulations for handling bees and beekeeping equipment.

**Physical Fitness.** Counselors should be aware of youth participants who may be allergic to bee stings and to pesticides and fungicides used in gardening.

**Safe Area or Course.** Counselors should take reasonable measures to provide participants with a safe gardening environment and well-constructed hives that pass USDA inspection.

**Equipment Selection and Maintenance.** Counselors should ensure gardening tools and equipment are well-maintained and hives follow USDA guidelines.

**Personal Safety Equipment.** Counselors should ensure all participants are wearing proper protective gardening clothing and equipment such as gloves, long pants, an air mask, and safety glasses when preparing and applying chemicals. Protective gear for beekeeping includes: hat, veil, coveralls, gloves, long sleeves, pants, and other protective devices.

**Applicable Laws.** Counselors teaching this merit badge must have experience with gardening tasks and tools and be recruited to do the work involved. As a rule, Scouting activities may not include activities for youth that, by law, they would not be allowed to do in the workplace. It is important also to obey restrictions manufacturers impose or suggest for the use of their tools or other products, or potentially hazardous chemicals such as pesticides, fungicides, and fertilizers.

**Discipline.** Counselors should take reasonable measures to ensure all participants are using gardening and beekeeping tools and equipment properly.

The "Sweet Sixteen of BSA Safety" procedures are available online by visiting [www.scouting.org/health-and-safety/gss/sweet16/](http://www.scouting.org/health-and-safety/gss/sweet16/).

# Requirements

1. Do the following:
  - a. Explain to your counselor the most likely hazards associated with gardening and what you should do to anticipate, help prevent, mitigate, and respond to these hazards.
  - b. Discuss the prevention of, and treatment for, health concerns that could occur while gardening, including cuts, scratches, puncture wounds, insect bites, anaphylactic shock, heat reactions, and reactions from exposure to pesticides and fertilizers.
2. Do the following, and discuss your observations throughout the process with your counselor:
  - a. Grow six vegetables, three from seeds and three from seedlings, through harvest.
  - b. Grow six flowers, three from seeds and three from seedlings, through flowering.
3. Give the nutritional value of the following:
  - a. Three root or tuber crops
  - b. Three vegetables that bear above the ground
  - c. Three fruits
4. Test 100 seeds for germination. Determine the percentage of seeds that germinate. Explain why you think some did not germinate.
5. Visit your county extension agent's office, local university agricultural college, nursery, or a botanical garden or arboretum. Report on what you learned.
6. Explain to your counselor how and why honey bees are used in pollinating food crops and the problems that face the bee population today. Discuss what the impact to humanity would be if there were no pollinators.

7. Identify five garden pests (insects, diseased plants). Recommend two solutions for each pest. At least one of the two solutions must be an organic method.
8. Do ONE of the following and record weekly observations. Discuss the results of your project with your counselor.
  - a. Build a compost bin and maintain it for 90 days.
  - b. Build a vermicompost bin (worm compost bin) and maintain it for 90 days.
  - c. Build a hydroponic garden containing three vegetables or herbs, or three ornamental plants. Maintain this garden through harvest or flowering, or for 90 days.
  - d. Build one water garden, either in a container (at least 12 by 6 inches and 6 inches deep), or in the ground as a small, decorative pond no larger than 6 by 3 feet and 24 inches deep. Maintain the water garden for 90 days.
  - e. Prepare a honey super for use on a hive or colony. Remove a filled honey super from the hive or colony and prepare the honey for sale.







## Contents

Gardening Basics . . . . .	9
Garden Types . . . . .	21
Growing Fruits and Vegetables . . . . .	37
Growing Ornamental Plants and Grasses . . . . .	49
Nurturing Your Garden . . . . .	56
All About Bees . . . . .	81
Gardening Resources . . . . .	94





# Gardening Basics



Humans have been growing plants for thousands of years. Farmers and horticulturists make their living growing food and other plants, while other people grow gardens for pleasure. Botanists and agricultural scientists study plants and how they grow.

To be a good gardener, you will need to understand the science of growing plants—how to prepare the soil, how to select and plant seeds, and how to care for the growing plants. When the plants have grown up, or matured, you can harvest their flowers, fruits, or vegetables—called produce—and sell or keep the produce.

Gardens feed us, heal our bodies, and give us beautiful flowers. Whatever kind of garden you choose to grow today, and whatever you want to be when you grow up, gardens will always be a part of your life.

## Regions of the United States

Before you plan your garden, find out about the agricultural region where you live. Knowing the region in which your garden is located will help you select the right types of plants to grow. For example, the directions for growing a particular seed packet may say that the plant will be winter hardy through zone 3. That means that anyone who lives in zones 4 through 13 can grow that particular plant outside without fear of it succumbing to the cold of winter.

You can get a map (more detailed than the one shown on the next page) of the agricultural regions for the United States from the U.S. Department of Agriculture (see the resources section at the end of this pamphlet). Use the map to locate your town and region.

# Hardiness Zones for the United States\*

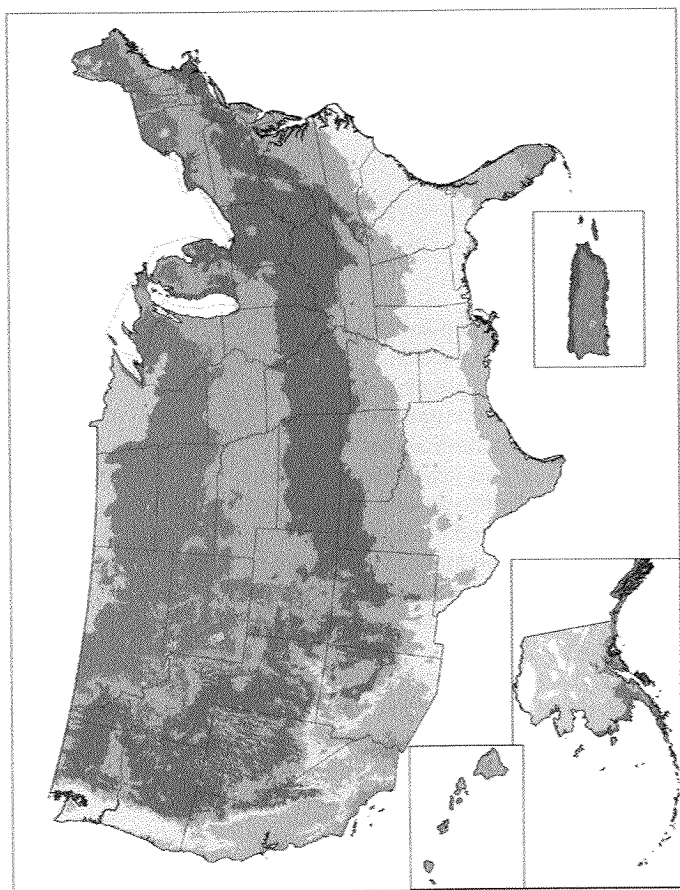

## Average Annual Extreme Minimum Temperature 1976-2005

Temp (F)	Zone	Temp (C)
-60 to -50	1	-51.1 to -45.6
-50 to -40	2	-45.6 to -40
-40 to -30	3	-40 to -34.4
-30 to -20	4	-34.4 to -28.9
-20 to -10	5	-28.9 to -23.3
-10 to 0	6	-23.3 to -17.8
0 to 10	7	-17.8 to -12.2
10 to 20	8	-12.2 to -6.7
20 to 30	9	-6.7 to -1.1
30 to 40	10	-1.1 to 4.4
40 to 50	11	4.4 to 10
50 to 60	12	10 to 15.6
60 to 70	13	15.6 to 21.1

\*This information comes from the USDA website.

The frost dates in the growing season chart are the averages for a light freeze (32 degrees); average temperatures in your local area may vary from those listed here. The possibility of frost occurring after the spring dates and before the fall dates is 50 percent. The following classification of freeze temperatures is usually based on the temperatures' effect on plants:

- **Light freeze:** 29 degrees to 32 degrees—tender plants killed, with little destructive effect on other plants
- **Moderate freeze:** 25 degrees to 28 degrees—a great amount of damage to most vegetation, with heavy damage to fruit blossoms and tender plants
- **Severe freeze:** 24 degrees and colder—most plants damaged or destroyed

Once you have determined the last frost date for your region, you can plan your garden. Your plants will need good sunlight, water, food, and soil. Most vegetables and fruits grow best in full sunlight. You will need

to decide whether to grow your garden in the ground or in containers. If you live in a house, find a nice sunny place in your yard. If you live in an apartment, use a barrel or large plastic or clay flowerpots to grow your garden. Then you can decide what kind of plants you want to grow, and what kind of plant food, called fertilizer, will help them grow. The chart showing growing regions provides a list of sample plants by USDA growing region.



## Average growing seasons in the United States\*

## Growing Season

City, State	No. of Days	Last Frost Spring	First Frost Fall
Mobile, Ala.	272	Feb. 27	Nov. 26
Juneau, Alaska	133	May 16	Sept. 26
Phoenix, Ariz.	308	Feb. 5	Dec. 15
Tucson, Ariz.	273	Feb. 28	Nov. 29
Pine Bluff, Ark.	234	Mar. 19	Nov. 8
Eureka, Calif.	324	Jan. 30	Dec. 15
Sacramento, Calif.	289	Feb. 14	Dec. 1
San Francisco, Calif.	**	**	**
Denver, Colo.	157	May 3	Oct. 8
Hartford, Conn.	167	April 25	Oct. 10
Wilmington, Del.	198	April 13	Oct. 29
Miami, Fla.	**	**	**
Tampa, Fla.	338	Jan. 28	Jan. 3
Athens, Ga.	224	March 28	Nov. 8
Savannah, Ga.	250	March 10	Nov. 15
Boise, Idaho	153	May 8	Oct. 9
Chicago, Ill.	187	April 22	Oct. 26
Springfield, Ill.	185	April 17	Oct. 19
Indianapolis, Ind.	180	April 22	Oct. 20
South Bend, Ind.	169	May 1	Oct. 18
Atlantic, Iowa	141	May 9	Sept. 28
Cedar Rapids, Iowa	161	April 29	Oct. 7
Topeka, Kan.	175	April 21	Oct. 14
Lexington, Ky.	190	April 17	Oct. 25

\*This information was taken from the USDA website.

\*\*Frosts do not occur every year in these locations.

City, State	No. of Days	Last Frost Spring	First Frost Fall
Monroe, La.	242	March 9	Nov. 7
New Orleans, La.	288	Feb. 20	Dec. 5
Portland, Maine	143	May 10	Sept. 30
Baltimore, Md.	231	March 26	Nov. 13
Worcester, Mass.	172	April 27	Oct. 17
Lansing, Mich.	140	May 13	Sept. 30
Marquette, Mich.	159	May 12	Oct. 19
Duluth, Minn.	122	May 21	Sept. 21
Willmar, Minn.	152	May 4	Oct. 4
Columbus, Miss.	215	March 27	Oct. 29
Vicksburg, Miss.	250	March 13	Nov. 18
Jefferson City, Mo.	173	April 26	Oct. 16
Fort Peck, Mont.	146	May 5	Sept. 28
Helena, Mont.	122	May 18	Sept. 18
Blair, Neb.	165	April 27	Oct. 10
North Platte, Neb.	136	May 11	Sept. 24
Las Vegas, Nev.	259	March 7	Nov. 21
Concord, N.H.	121	May 23	Sept. 22
Newark, N.J.	219	April 4	Nov. 10
Carlsbad, N.M.	223	March 29	Nov. 7
Los Alamos, N.M.	157	May 8	Oct. 13
Albany, N.Y.	144	May 7	Sept. 29
Syracuse, N.Y.	170	April 28	Oct. 16
Fayetteville, N.C.	212	April 2	Oct. 31
Bismarck, N.D.	129	May 14	Sept. 20
Akron, Ohio	168	May 3	Oct. 18

<b>City, State</b>	<b>No. of Days</b>	<b>Last Frost Spring</b>	<b>First Frost Fall</b>
Cincinnati, Ohio	195	April 14	Oct. 27
Lawton, Okla.	217	April 1	Nov. 5
Tulsa, Okla.	218	March 30	Nov. 4
Pendleton, Ore.	188	April 15	Oct. 21
Portland, Ore.	217	April 3	Nov. 7
Carlisle, Pa.	182	April 20	Oct. 20
Williamsport, Pa.	168	April 29	Oct. 15
Kingston, R.I.	144	May 8	Sept. 30
Charleston, S.C.	253	March 11	Nov. 20
Columbia, S.C.	211	April 4	Nov. 2
Rapid City, S.D.	145	May 7	Sept. 29
Memphis, Tenn.	228	March 23	Nov. 7
Nashville, Tenn.	207	April 5	Oct. 29
Amarillo, Texas	197	April 14	Oct. 29
Denton, Texas	231	March 25	Nov. 12
San Antonio, Texas	265	March 3	Nov. 24
Cedar City, Utah	134	May 20	Oct. 2
Spanish Fork, Utah	156	May 8	Oct. 12
Burlington, Vt.	142	May 11	Oct. 1
Norfolk, Va.	239	March 23	Nov. 17
Richmond, Va.	198	April 10	Oct. 26
Seattle, Wash.	232	March 24	Nov. 11
Spokane, Wash.	153	May 4	Oct. 5
Parkersburg, W.Va.	175	April 25	Oct. 18
Green Bay, Wis.	143	May 12	Oct. 2
Janesville, Wis.	164	April 28	Oct. 10
Casper, Wyo.	123	May 22	Sept. 22



## USDA growing regions and suggested plants\*

## Growing Regions

USDA Zone,  
Low Temperature,  
Example Cities

Plant by Botanical Name (and Common Name)

### Zone 1

Below -50 degrees F  
Fairbanks, Alaska

*Betula glandulosa* (Dwarf birch)  
*Empetrum nigrum* (Crowberry)  
*Populus tremuloides* (Quaking aspen)  
*Potentilla pensylvanica* (Pennsylvania cinquefoil)  
*Rhododendron lapponicum*  
(Lapland rhododendron)  
*Salix reticulata* (Netleaf willow)

### Zone 2

-50 to -40 degrees F  
Prudhoe Bay, Alaska  
Unalakleet, Alaska  
Pinecreek, Minn.

*Arctostaphylos uva-ursi* (Bearberry)  
*Betula papyrifera* (Paper birch)  
*Cornus canadensis* (Bunchberry dogwood)  
*Elaeagnus commutata* (Silverberry)  
*Larix laricina* (Eastern larch)  
*Potentilla fruticosa* (Bush cinquefoil)  
*Ulmus americana* (American elm)  
*Viburnum trilobum* (American cranberry bush)

### Zone 3

-40 to -30 degrees F  
International Falls, Minn.  
St. Michael, Alaska  
Tomahawk, Wis.  
Sidney, Mont.

*Berberis thunbergii* (Japanese bayberry)  
*Betula pendula* (European white birch)  
*Cornus alba* (Tatarian dogwood)  
*Elaeagnus angustifolia* (Russian olive)  
*Juniperus communis* (Common juniper)  
*Lonicera tatarica* (Tatarian honeysuckle)  
*Malus baccata* (Siberian crabapple)  
*Rhododendron* southern Indian hybrids  
(Indian azalea)  
*Syringa vulgaris* (Common lilac)  
*Thuja occidentalis* (American arborvitae)

\*This information was taken from the USDA website.

**Zone 4**

-30 to -20 degrees  
 Minneapolis/  
 St. Paul, Minn.  
 Lewistown, Mont.  
 Northwood, Iowa  
 Omaha, Neb.

*Acer saccharum* (Sugar maple)  
*Acer platanoides* (Norway maple)  
*Aristolochia durior* (Dutchman's pipe)  
*Forsythia ovata* (Early forsythia)  
*Hydrangea paniculata* (Panicle hydrangea)  
*Juniperus chinensis* (Chinese juniper)  
*Ligustrum amurense* (Amur river privet)  
*Parthenocissus quinquefolia* (Virginia creeper)  
*Spiraea x vanhouttei* (Vanhouffe spirea)

**Zone 5**

-20 to -10 degrees F  
 Des Moines, Iowa  
 Chicago, Ill.  
 Columbia, Mo.  
 Mansfield, Pa.

*Cornus florida* (Flowering dogwood)  
*Deutzia gracilis* (Slender deutzia)  
*Forsythia suspensa* (Weeping forsythia)  
*Ginkgo biloba* (Ginkgo, Maidenhair tree)  
*Hibiscus syriacus* (Shrub althea)  
*Iberis sempervirens* (Evergreen candytuft)  
*Lagerstroemia indica* (Crape myrtle)  
*Ligustrum vulgare* (Common privet)  
*Mahonia aquifolium* (Oregon hollygrape)  
*Metasequoia glyptostroboides*  
 (Dawn redwood)  
*Rhododendron "America"* (Hybrid rhododendron)  
*Paithenocissus tricuspidata* (Boston ivy)  
*Rosa multiflora* (Japanese rose)  
*Taxus cuspidata* (Japanese yew)  
*Viburnum burkwoodii* (Burkwood viburnum)

**Zone 6**

-10 to 0 degrees F  
 St. Louis, Mo.  
 Lebanon, Pa.  
 McMinnville, Tenn.  
 Branson, Mo.

*Acer palmatum* (Japanese maple)  
*Buxus sempervirens* (Common boxwood)  
*Cercis chinensis* (Chinese redbud)  
*Chamaecyparis lawsoniana* (Lawson cypress)  
*Cytisus x praecox* (Warminster broom)  
*Euonymus follunei* (Winter creeper)  
*Hedera helix* (English ivy)  
*Ilex opaca* (American holly)  
*Ligustrum ovalifolium* (California privet)  
*Pieris japonica* (Japanese andromeda)  
*Prunus yedoensis* (Yoshino cherry)

**Zone 7**

0 to 10 degrees F  
 Oklahoma City, Okla.  
 South Boston, Va.  
 Little Rock, Ark.  
 Griffin, Ga.

*Acer macrophyllum* (Bigleaf maple)  
*Rhododendron Kurume* hybrids (Kurume azalea)  
*Cedrus atlantica* (Atlas cedar)  
*Cotoneaster microphylla* (Small-leaf cotoneaster)  
*Ilex aquifolium* (English holly)  
*Taxus baccata* (English yew)

**Zone 8**

10 to 20 degrees F  
 Tifton, Ga.  
 Dallas, Texas  
 Austin, Texas  
 Gainesville, Fla.

*Arbutus unedo* (Strawberry tree)  
*Choisya temata* (Mexican orange)  
*Olearia haastii* (New Zealand daisy bush)  
*Pittosporum tobira* (Japanese pittosporum)  
*Prunus laurocerasus* (Cherry laurel)  
*Viburnum tinus* (Laurestinus)

**Zone 9**

20 to 30 degrees F  
 Houston, Texas  
 St. Augustine, Fla.  
 Brownsville, Texas  
 Fort Pierce, Fla.

*Asparagus setaceus* (Asparagus fern)  
*Eucalyptus globulus* (Tasmanian blue gum)  
*Syzygium paniculatum* (Australian bush cherry)  
*Fuchsia* hybrids (Fuchsia)  
*Grevillea robusta* (Silk oak)  
*Schinus molle* (California pepper tree)

**Zone 10**

30 to 40 degrees F  
 Naples, Fla.  
 Victorville, Calif.  
 Miami, Fla.  
 Phoenix, Ariz.

*Bougainvillea spectabilis* (Bougainvillea)  
*Cassia fistula* (Golden shower)  
*Eucalyptus citriodora* (Lemon eucalyptus)  
*Ficus elastica* (Rubber plant)  
*Ensete ventricosum* (Ensete)  
*Roystonea regia* (Royal palm)

**Zone 11 12 13**

Above 40 degrees F  
 Honolulu, Hawaii  
 San Juan, Puerto Rico

*Bougainvillea spectabilis* (Bougainvillea)  
*Cassia fistula* (Golden shower)  
*Eucalyptus citriodora* (Lemon eucalyptus)  
*Ficus elastica* (Rubber plant)  
*Ensete ventricosum* (Ensete)  
*Roystonea regia* (Royal palm)

## Soil

The earth in which plants grow is called soil. The upper layers of soil are usually made up of decaying plant material such as leaves, mulch, and grass clippings. The lower layers of soil are made up of rocks and minerals that have crumbled with age and wear. Rain, earthworms, fungi, bacteria, and small animals help the upper layers break down. When the upper and lower layers combine, soil is formed. Sometimes, a gardener may need to help the layers mix. This is called tilling, or turning the soil.

There are many different kinds of soil. The soil at your local playground might be different from the soil at your home. Some kinds of soil contain materials that are better for garden plots, and some kinds of plants grow only in certain kinds of soil.



You can test the soil in your garden plot if you are unsure whether it needs to be improved with compost, topsoil, humus, fertilizer, or other additive. Inexpensive soil test kits are available at your local garden center. For a more detailed test, your county extension service will test your soil samples for free or at a minimal cost.



## Soil Types

Here are some of the kinds of soil you might find in your neighborhood.

**Sandy loam soil** is good for most plants. It contains a good mixture of sand and decaying materials. However, too much sand will dry out quickly and is not good for gardens. If the area where you want to plant a garden is purely sand, add topsoil, organic humus, or compost, and then till the plot before planting.

**Clay loam soil** is heavy and makes gardening difficult. It dries out slowly and sometimes forms a crust on top. Clay is not good for gardening unless you add sand and organic material, such as compost, to make it easier for plant roots to grow and water to drain. If the area where you want to plant a garden contains hard clay, add sand, topsoil, organic humus, or compost, and then till the plot before planting.

**Mucky soil** is dark, rich in nutrients, and very good for growing many different kinds of vegetables. The nutrients from decaying organic material provide a lot of food for plants. If the mucky soil in the area where you want to plant a garden does not drain well, add sand and then till the plot before planting.

**Peat soil** contains decaying vegetable matter, usually from a forest floor, that is high in carbon. Carbon is a nutrient that helps plants grow. Peat soil is light and almost dusty. If the area where you want to plant a garden contains only peat, add topsoil, organic humus, or compost, and then till the plot before planting.

**Topsoil** is made up of decaying vegetable matter, sand, and peat. It dries out quickly and should be mixed with heavier soils to add nutrients. Vegetables should not be grown in topsoil alone. If the area where you want to plant a garden contains only topsoil, add organic humus or potting soil, and then till the plot before planting.

**Potting soil** is commercially prepared and packaged soil that you buy at a garden center. It is available in different mixtures for specific gardening purposes. You can even buy potting soil with the fertilizer already mixed into it. However, if you want an organic garden, or one that grows without synthetic fertilizers and additives, use only certified organic potting soil.

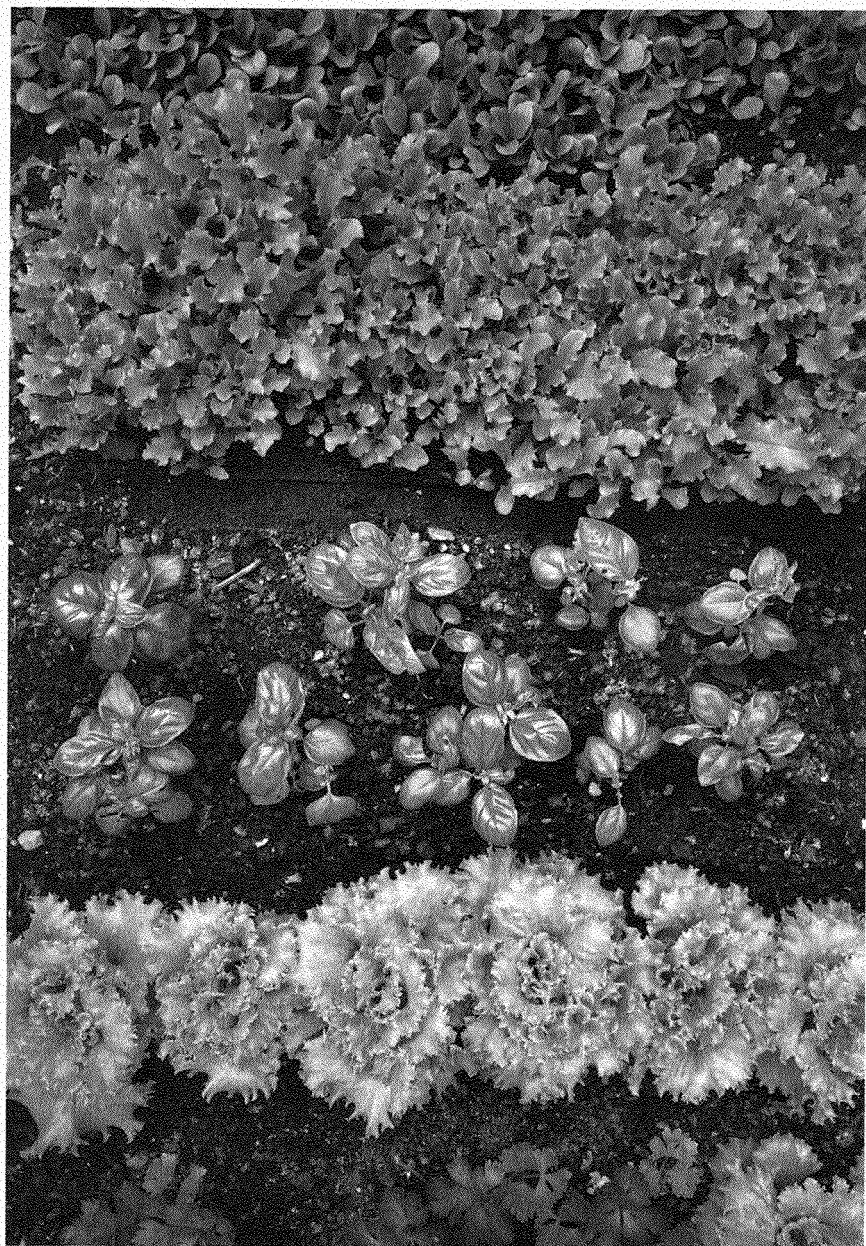

# Garden Types

As you learned earlier, people grow gardens for different reasons. Flower gardens provide flowers for many different uses. Vegetable and fruit gardens provide food. Orchards, or gardens of fruit or nut trees, also provide food. You can dress up your food garden by planting a few flower seeds around the edges of the plot or in containers. It is fun to watch food and flowers grow in the same garden because you can see the differences in how quickly each grows and how long each takes to mature.

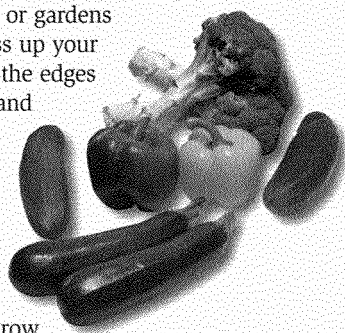

**Vegetables like cucumbers, broccoli, peppers, and zucchini bear above the ground.**

## Food Gardens

You can grow many different crops in a food garden. Some of the most popular and easiest to grow are tomatoes, strawberries, beans, carrots, corn, collards, and broccoli. Fruit and nut trees and vines take years to grow. Beans, corn, and tomatoes grow quickly and can be harvested within a couple of months. They are often called summer crops because they need warm soil and a lot of sunlight to grow. Strawberries, collards, and broccoli need cool weather to grow well. They often are called winter crops because they grow during the winter months in warmer agricultural regions.

Food gardens can be grown in the ground or in containers of soil or water. The kind of water garden where you grow food without using soil is called a *hydroponic* garden.

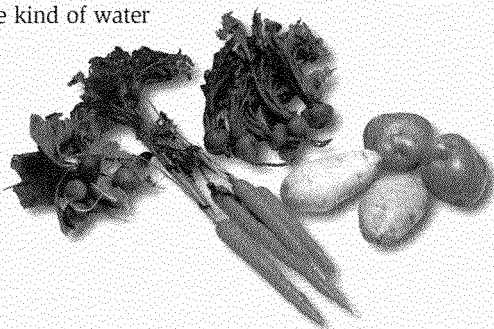

**Turnips, carrots, potatoes, and radishes are examples of root and tuber vegetables, which bear below the ground.**

## Flower Gardens

You can grow flowers in many different ways. Containers or flower pots allow you to arrange flower gardens in different ways and places. Flower beds are permanent displays. You can plant a flower bed directly in the ground or in a raised area surrounded by landscaping timbers or stone. Flower gardens provide color, texture, and seasonal variety. They also provide homes for wildlife. Birds, insects, amphibians, and reptiles thrive in natural areas like flower gardens.



## Alternative Gardening

You can have a garden anywhere. If you live in an apartment, you can grow plants in containers. If you live in a city, you might be able to grow crops in a community garden. If you live in the desert, you can use water-wise growing methods to cultivate strong plants. And if you like to experiment, you might try hydroponics, aquaculture, or a water garden.

## Urban Gardening

Living in a city does not mean that you cannot earn your Gardening merit badge. Urban, or city, gardening can be very rewarding. You can put together your own minigarden by using containers to grow plants indoors, or on balconies, rooftops, doorways, windowsills, and even hanging from eaves. Books that specialize in container gardening can help show you how.



## Succulents

If you live in an arid location, succulents may be the solution to your gardening challenge. Succulents are ideal for growing in dry areas because they have stems that store water in times of drought. Thick skin and spines discourage animals and insects. Many succulents have beautiful flowers; some even bear delicious fruits.

Cacti will range in size from a few inches to giant varieties such as the saguaro and yucca, which can grow to more than 50 feet in height and weigh up to 8 tons.

Almost all cacti are native to the American continents, from Canada to Brazil. Some succulents, such as *Portulaca afra* (moss rose), *Crassulaceae* (jade plant), and *Echeveria* (sedum, hens and chicks), are native to Africa and have shrubby rather than spiny branches. Their plump leaves make them—fittingly—“succulent!”

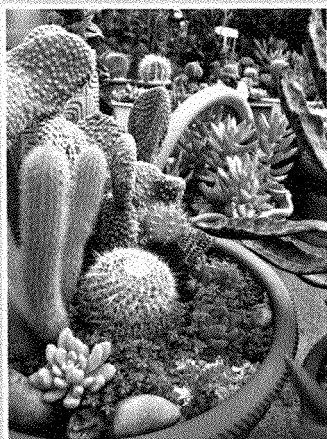

Most major cities, such as New York City, Chicago, Philadelphia, and Los Angeles, have urban gardening programs, and many smaller cities have active community gardens. These city programs allow a gardener or group of gardeners to grow crops on a small plot of unused land. Most times, these plots are vacant fields that have become overwhelmed with weeds or litter. The gardeners clean up the plot and build vegetable gardens. They share the harvested crops with one another and with less fortunate people, including soup kitchens that feed homeless people.

These kinds of programs ensure the continuation of community-managed gardens and open space in low- and moderate-income neighborhoods. Your county agricultural extension agent or parks department can help you learn about urban gardens in your city.

---

To learn more about how to preserve land for community gardens in your city, contact the Trust for Public Land. (See the resources section.)

---

## Container Gardening

Container gardening is simply growing plants in anything but the ground. It is the easiest kind of gardening because it can be done anywhere at any time of year. You can grow plants in almost any container that will hold soil. Some examples include:



- **Clay**—the inexpensive reddish-brown pots made of terra-cotta that you see in every garden center
- **Ceramic or glass**—fancier containers purchased for their beauty
- **Concrete**—heavy-duty planters that are often large and difficult to move
- **Plastic**—low-cost alternative to ceramic or glass containers
- **Wood**—old barrels and livestock water troughs that add a casual look to a garden
- **Synthetic**—relatively new to the garden market, containers that look like heavy terra-cotta or concrete containers but are in fact made of heavy-duty foam and are very lightweight

Other fun containers include old leather work boots, old bath and wash tubs, old wooden boxes or dresser drawers, and recycled plastics such as 2-liter drink bottles or gallon milk jugs.

Some vegetables, such as radishes, are naturally small and easy to grow in containers. There are also special varieties of vegetables that were developed to grow in small spaces. Look for the terms "patio" and "bush" on seed packets and seedling tags. Most of these can be grown in a 2- to 5-gallon pot. No matter what size container you use, it must provide good drainage and be filled with the appropriate soil.

## Water-Wise Gardening

One of the easiest ways to foolproof a garden is to grow plants that will survive if you forget to water them. The term *water wise* means being smart about water conservation by applying water in well-controlled amounts and locations in your garden. The concept of water-wise gardening is based on the following seven rules:

- 1. Plan and design for water conservation** and beauty from the start. A little research into what grows where, and what combinations work well, can create a colorful year-round garden.
- 2. Create practical grassy areas** of manageable sizes, shapes, and appropriate grasses. Natural areas require less water. Use them as widely as possible.
- 3. Choose plants that have low water requirements.** Group plants of similar water needs. Then experiment to determine how much and how often to water the plants.
- 4. Prepare the soil.** Use compost or manure as needed by the site and the type of plants used.
- 5. Use rocks or organic mulch,** such as chips or pine straw, to reduce evaporation and to keep the soil cool.
- 6. Irrigate efficiently** using properly designed systems (including hose attachments) and by applying the right amount of water at the right time. Early morning is best for watering plants because it reduces evaporation and the spread of plant disease.
- 7. Maintain your landscape properly** by mowing, weeding, pruning, and fertilizing at the right time of year.



**Caution:** Do not use arsenic-treated wood containers or timbers to grow fruits or vegetables that you or wildlife will eat. This kind of wood leeches, or leaks, poisons into the soil. In turn, plant roots absorb the poisons and become toxic to people and wildlife. This kind of wood is used to build wooden decks, some outdoor furniture, and some outdoor playground equipment. If you cannot find a label that says the wood is untreated, do not use it. Find an alternative.

The trees and plants listed here grow successfully with limited water. They will grow in most areas of North America, but check with your local extension service to verify which ones are best suited to your agricultural region.

### Trees

Ash, crape myrtle, cypress, firethorn, juniper, oak, pine

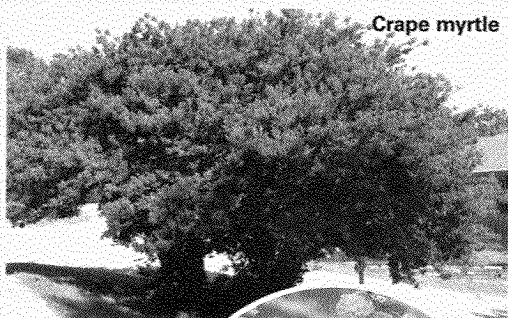

Crape myrtle

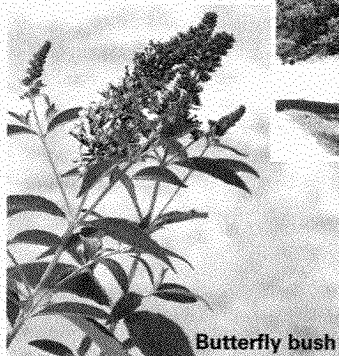

Butterfly bush



Lantana

### Shrubs

Butterfly bush, chaste tree, cotoneaster, heavenly bamboo, mallow, pomegranate, shrub juniper



Zinnia

### Ground Covers, Vines

Carolina Jessamine, creeping juniper, gazania, ice plant, lantana, verbena, wisteria (after established)

### Perennials, Bulbs, Annuals

Agave, aloe, blanket flower, blue fescue, cactus, coreopsis, daylily (when established), desert marigold, fountain grass, iris (bearded), lamb's ear, lily of the Nile, red valerian, sage, zinnia

## Aquaculture

Aquaculture is the practice of growing plants and fish as sources of food in a controlled freshwater, saltwater, or brackish water environment. Most aquaculture farmers grow seaweed, fish, or crustaceans like crabs or shrimp.

**Hydroponics.** Hydroponics is the science of growing plants without dirt. The term *hydroponics* means “water working.” Growing plants in a water and nutrient solution, without soil, allows a gardener to grow plants more efficiently with less labor and time. There are many benefits to growing plants using hydroponics:

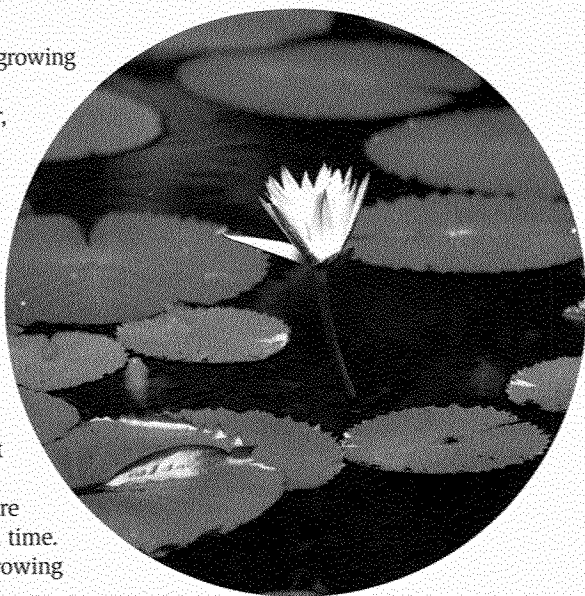

- Most hobby hydroponic gardens require less work than soil gardens because there is no soil to till or weeds to pull.
- Eliminating the soil in a garden also eliminates all soil-borne diseases.
- A hydroponic garden does not use as much water as a soil garden does because weeds do not grow in a hydroponic garden.
- In a hydroponic garden, plants can grow closer together, thereby increasing your harvest from the same size garden.
- A small hydroponic garden can be set up almost anywhere.
- Some studies suggest that hydroponic produce is higher in nutritional value than field-grown crops because the nutrients are controlled and environmental factors like pollution and drought are eliminated.
- Hydroponic plants can be grown year-round indoors.

Tomatoes, peppers, cucumbers, lettuce, and beans often are grown using hydroponics. In a soil garden, plants get most nutrients from the soil. In hydroponics, plants get nutrients directly from the water in which they grow. Some systems

use an inert growing medium, such as perlite (a lightweight volcanic rock) or expanded clay pebbles (artificial absorbent stones) in place of soil. These growing media support the roots and retain and circulate nutrients to allow the plants to absorb them easily. Inert growing mediums also eliminate the need for soil and the plant diseases it can carry. In other hydroponic systems, plant roots are suspended in a grow channel in which water and nutrients flow.

Hydroponics is divided into active and passive systems. Active systems use pumps to circulate a nutrient solution through the plants' root tips. This method is preferred by large-scale growers to cultivate fast-growing crops like lettuce. Passive systems work without pumps. The plants' root tips are set in a nutrient solution or growing medium, and the roots draw nutrients from the solution or surrounding medium to nourish the plant. This method is best for slow-growing crops, such as tomatoes, and is used by hobbyists and small-scale growers.

The following are four common hydroponic gardening techniques:

**Ebb and Flow.** The nutrient solution is pumped to all plants at the same time, left in the grow channel for a specific period of time, then pumped out of the grow channel. This method is similar to the flow of ocean tides into and out of river basins, harbors, and bays.

**Drip Method.** The nutrient solution drips slowly into the plant pots, usually on a timed basis such as 10 minutes every hour. The drip system is used most often with a growing medium. Tomatoes, peppers, and cucumbers often are grown using this method.

**Nutrient Film Technique (NFT).** This method floods the grow channel with a nutrient solution and then drains it about every 15 minutes. The root tips are exposed to the nutrient solution while the root tops stay exposed to air. Most plants grown this way are fed on a frequent timed cycle. Lettuce and other leafy crops are often grown using this method.

**Passive System.** This method uses a stationary pool of nutrient solution. The plants' root tips dangle in the nutrient solution and pull what they need from it. The plants' roots stay mostly exposed to air, giving the plants access to oxygen. This method is slower, so harvesting takes longer. Tomatoes, peppers, and cucumbers can be grown using this method.

## Cooler Float Grower

Try this floating system, made with plastic foam coolers that cost about \$3 each.

### Materials Needed

- Two clean plastic foam coolers with tapered sides, large enough to hold several liters of water
- Heavy-duty trash can liners or plastic sheeting
- Duct tape
- Seed-starting trays and seeds (or purchased starter plants) in six 2-by-2-inch compartments. Basil and loose-leaf lettuce (fancy types—not heading lettuce) work well and are easy to grow in the cooler grower.
- Utility knife and scissors
- One 3-watt aquarium pump and tubing
- T-valve to split the tubing for the two coolers
- Air stones (used in fish aquariums to aerate water)
- HID (high intensity discharge) garden lamp (optional)
- Growing medium (a mixture with a 2-1 ratio of perlite to vermiculite is suggested)
- Nutrient (Contact your local hydroponics supplier for a mixture suitable for the plants you plan to grow. For plants that do not fruit, such as basil and lettuce varieties, you will only need a “vegetative” or “grow” hydroponic nutrient solution. Many varieties are available and all are similar and suitable for this project. Mix the nutrient solution according to the instructions on the label.)



## How to Make Your Hydroponic System

Because the plastic foam will gradually permit liquids to seep out, line the inside of each cooler with two layers of strong plastic sheeting, such as a heavy-duty trash can liner, secured with duct tape along the outside rim.

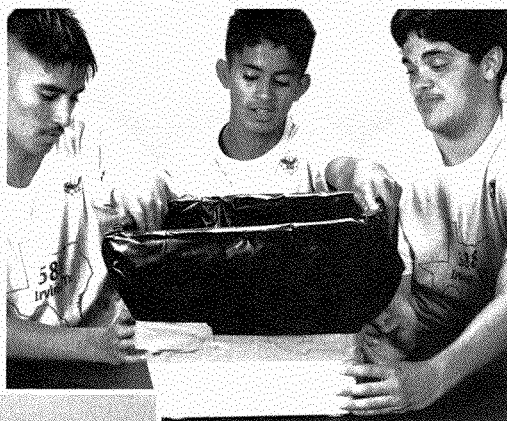

Flip the lids over and, using a utility knife, cut six spaces on each lid to accommodate the plants. Cut the spaces to the size of the starter plant containers for a snug fit. Because the lids are domed, the top edges of the lid rest several inches below the rim of the cooler when the lids are flipped upside down.

If you are starting from seed, plant the seeds in a loose mixture of perlite and vermiculite in the seed-starting trays. Feed the seeds with plain tap water until the plants come up, then switch to a diluted vegetative growth solution—a three-part powdered mix that is sold as a package. You usually mix  $\frac{1}{4}$  teaspoon of calcium nitrate,  $\frac{1}{4}$  teaspoon “grow” mix, and  $\frac{1}{8}$  teaspoon magnesium sulfate with 1 gallon of water per batch. Another popular source of vegetative nutrient solution is a concentrated liquid mix that has everything already added to it for good vegetative growth.





Sterilize your scissors by rinsing them with a mixture of 1 part chlorine bleach and 20 parts water and then flushing well with clean water.

When the young seedlings are ready, separate the cells of the seed-starting trays, cut off the bottom of each cell with sterilized scissors, gently shake out the growing medium (it falls right out), and insert the individual cells into the holes in the cooler lids.

The cells fit snugly into the holes and the plant roots easily dangle into the nutrient solution. The bottom leaves of the plants should be large enough to prevent the plants from slipping into the cooler.



Cut a hole in the side of each cooler near the top to accommodate an air tube connected to an air stone at the bottom of each cooler. An aquarium pump provides constant, gentle, bubbling oxygen.

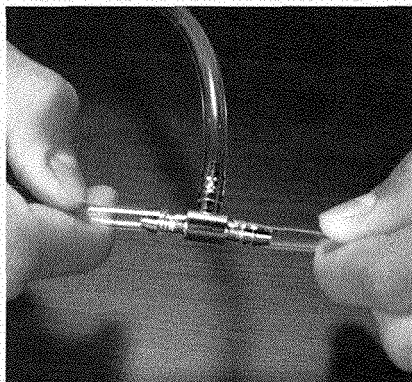

Split the air line coming out of the pump and run air tubes to both coolers. One 3-watt pump will provide enough oxygen for two coolers. Both coolers will easily fit under a 250-watt metal halide light that is connected to a timer set for a 12-hour photoperiod. Position the light about a foot or so from the plants to make sure they are not exposed to too much radiant heat.

Most salad greens and lettuce plants go from seed to harvest in just over a month. If you selectively harvest when the plants start to mature, pull off enough greens to make a few salads each day for the next few weeks. Do not wait too long to harvest because overly mature greens can become bitter. Greens will stay fresh in the refrigerator for about a week. If you harvest all at once, you will have enough greens for a few mighty salads. If you have new starts continually going and regularly replace old plants with new ones, you can always have enough greens for the table.

Reprinted with permission from *The Growing Edge* magazine, Corvallis, Oregon, published by New Moon Publishing Inc. The plan was adapted from a system first profiled in "A Beginner's Guide to Hawaiian Hydroponics," which was adapted from the instructional manual "Hydroponics in Hawaii Using Black Lava Rock: 'Eze Gro Kit'" by Charles E. Musgrove, *The Growing Edge*, Vol. 11, No. 4.

## Self-Watering Potted Plant

This clever and simple hydroponic system makes a good starter project.

### Materials Needed

- 8-inch plastic pot
- 10-inch watering saucer or shallow plastic tray
- Starter plant (Coleus works well.)
- Growing medium, such as expanded clay or perlite
- Nutrient (Contact your local hydroponics supplier for a mixture suitable for the plants you plan to grow. For plants that do not fruit, such as basil and lettuce varieties, you will only need a "vegetative" or "grow" hydroponic nutrient solution. Many varieties are available and all are similar and suitable for this project. Mix the nutrient solution according to the directions on the label.)

### How to Make Your Hydroponic System

Fill the plastic pot with growing medium. Gently rinse it with tap water, allowing the surplus to drain. Set the pot on the watering saucer. Place a germinated plant into the pot and carefully arrange the roots so that they are distributed through the growing medium. Pour a small quantity of the prepared nutrient solution into the saucer or tray. The plant will absorb the nutrients via capillary action, in which the higher pressure zone on one side of the plant draws a substance from the lower pressure side in order to equalize the pressure. In this case, the medium in the upper container wants more nutrient solution as it dries



out, so the material between the medium and the nutrient solution serves as a conduit for the transfer of water and nutrients as needed.

Check the saucer daily to make sure the mix does not dry out. Never pour the nutrient solution into the top of the pot; always add the nutrient to the tray or saucer. It's better for the roots to be fed from the bottom rather than the top, and you reduce the risk of overflow out of the saucer by applying too much nutrient solution to the top of the plant. By allowing the nutrient solution to sit in the saucer, the medium will absorb only what the plant needs. If the saucer is regularly topped off with nutrient solution, the plant will always have a reserve to soak up when necessary.

Reprinted with permission from *The Growing Edge* magazine, Corvallis, Oregon, published by New Moon Publishing Inc. This easy hydroponic system was first featured in "The Growing World of Hydroponics," by Rob Smith, in *The Growing Edge* magazine, Vol. 11, No. 1.

**Water Gardening.** The difference between water gardening and hydroponics is that a water garden mimics a natural area at or just beyond the edge of a body of water, like a beach. Think about the edge of a pond or lake you might have visited. Do you remember how many different kinds of plants were growing along the water's edge?

A water garden brings those kinds of plants to your home, patio, or yard. Indoor water gardens offer a peaceful, pretty, and different kind of garden for you to enjoy. Outdoor water gardens bring the same elements to your yard, and also provide a home and feeding area for wildlife, such as birds, insects, fish, amphibians, and reptiles.

You can grow a water garden in any container that holds water without leaking. Plastic and heavy glass bowls make the best water gardens. Wooden tubs, concrete bowls, or terra cotta pots that have been sealed with a waterproofing agent are also suitable. You can grow floating plants, such as water lilies, or you can add a soil basket and grow plants that require more support for their roots, such as bamboo or cattails.

## Make a Water Garden

To build a water garden, you will need the following supplies:

- Waterproof container at least 6 inches deep for floating plant water garden, 24 inches deep for water gardens that will contain soil baskets and large plants
- Water plants
- Soil and soil baskets for large plants (baskets should be twice as large as the plant's root ball)
- Chlorine neutralizer (the same kind used for aquariums to counteract the chlorine added to tap water)
- Gravel, clean stones, or decorative marbles for the base of the container
- Nutrient solution, if required (Ask the garden center whether any is required for the plants you choose.)
- Recycled gallon milk container or a clean bucket

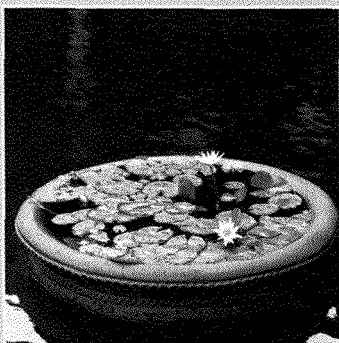

Try to build your water garden where it will reside permanently, rather than moving it after it is completed. Once you have decided how large the water garden will be, and where you will place it, do the following:

**Step 1**—Wash the container with a gentle dish soap. Avoid detergent or antibacterial soaps, as they might harm delicate plants.

**Step 2**—Place any decorative stones, gravel, or marbles in the bottom of the container.

**Step 3**—Fill the container with tap water to 2 inches from the top.

**Step 4**—Add the correct amount of chlorine neutralizer for your container. For small containers about the diameter of a dinner plate, one drop is sufficient. For large containers, mix the neutralizer with tap water in an empty milk jug or bucket according to the instructions per gallon. Fill your container with the neutralized water.

**Step 5, small garden**—Add the plants, arranging them however you like. Add the nutrient solution if required.

**Step 5, large garden**—Fill soil baskets half full of soil. Place large plant roots into soil baskets. Cover the roots with soil to approximately 1 inch from the top of the container.

**Step 6**—Slowly submerge the soil baskets into the water garden, allowing air bubbles to dissipate as you sink the basket.

**Step 7**—Add any floating plants.



# Growing Fruits and Vegetables

Fruits and vegetables grow on plants, vines, and trees. Most grow seasonally, but some plants, such as herbs, will grow year-round in a sunny indoor location like a windowsill. In warm climates, beets, carrots, squash, and tomatoes grow year-round.

## Cool Season

Fruits and vegetables that grow best during fall and winter are called cool-season plants. They need cool temperatures for their crops to ripen. Examples of cool-season fruits and vegetables are apples, broccoli, brussels sprouts, cabbage, celery, collards, grapefruit, kale, lettuce, peas, potatoes, spinach, and strawberries.

## Warm Season

Fruits and vegetables that grow best during spring and summer are called warm-season plants. They need warm temperatures for their crops to ripen. Examples of warm-season fruits and vegetables are beans, blackberries, blueberries, cantaloupe, carrots, corn, cucumber, okra, peppers, squash, tomatoes, and watermelon.

## Any Season: Growing Herbs

Herbs have been used for thousands of years to cure illness, flavor foods, dye cloth, make cosmetics and perfumes, and freshen the air. You probably have pepper, garlic, and parsley in your kitchen right now. These and many other herbs are grown for their flavor, aroma, and beauty. Herbs are fun and most are easy to grow year-round in a sunny window.

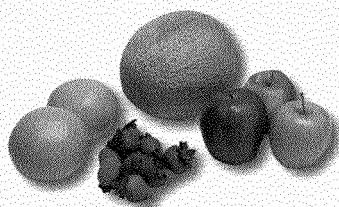

Cool-season fruits



Cool-season vegetables

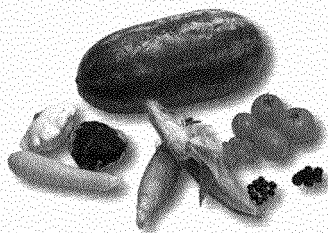

Warm-season crops



Basil

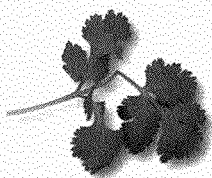

Cilantro



Parsley



Rosemary



Thyme

Other herbs and growing suggestions are listed here.

- **Basil** (*Ocimum basilicum*) will grow to a height of 2 to 3 feet; a dwarf variety does well in containers. Basil needs moist soil and full sun; an east or south windowsill is best.
- **Coriander** (*Coriandrum sativum*), also known as **Chinese parsley** or **cilantro**. This herb (the leaves) and spice (the seeds) give Mexican and Chinese dishes their oomph. You can grow coriander right from the seeds in your spice rack! Coriander grows 12 to 15 inches high. Transplant it outdoors in the spring alongside a few tomatoes, scallions, and peppers. Full sun and moderate water will sustain coriander through its early months.
- **Lavender** (*Lavandula*) is a woody evergreen shrub grown for its fragrant oil. It grows to a height of 1 to 3 feet. The oil is used to make soaps, lotions, perfumes, and air fresheners. You can use the dried flowers in arts and crafts projects. Lavender plants need a sunny location, good drainage, and average soil. Lavender grows best in the ground.
- **Parsley** (*Apiaceae*) is an excellent choice for an indoor herb garden. Mature plants range from 6 to 12 inches in height. Parsley grows best in moist soil with full sun in winter. Transplanted to the outdoor garden, parsley needs moderate shade to continue growing during the hot summer months. Seeds should be soaked overnight in warm water to help germination, which can take up to four weeks. It is easiest to purchase a small parsley plant from a garden center.
- *Salvia officinalis* is one of more than 60 types of **sage** grown by gardeners. It is the most aromatic of the salvias, growing to a height of 30 inches. Definitely destined for transplant, salvia adds color and texture to an indoor herb garden. It needs full sun and regular water to thrive.
- **Rosemary** (*Rosmarinus officinalis*) is a woody plant and needs its own container. Whether a climbing or shrub variety, rosemary is an excellent plant for landscaping. It grows almost anywhere there is sun. Once established, it can tolerate drought. Full sun and moderate water will sustain rosemary until it is moved outdoors in spring.
- **Thyme** (*Thymus vulgaris*) is cousin to the mint plant and makes a wonderful addition to any herb garden. This small, woody shrub grows to only 4 to 12 inches. Thyme is at home in a rock garden with a little shade. It is happiest in its own container when indoors. It needs moderate water and full winter sun.



## Tools and Equipment

No matter what kind of garden you choose to grow, you will use special tools—called implements—to help you work with your garden. You probably will need a spade or small shovel, a hoe, a rake, a yardstick, bamboo or other wooden stakes, and stretchable garden string. If you do not have these tools, you can use an old kitchen serving spoon and fork for digging, and strips of old socks or stockings instead of string to secure your plants to the supports.

You also might want a pair of garden gloves to help protect your hands. Thrift stores, hardware stores, and discount garden centers are good places to find garden implements.

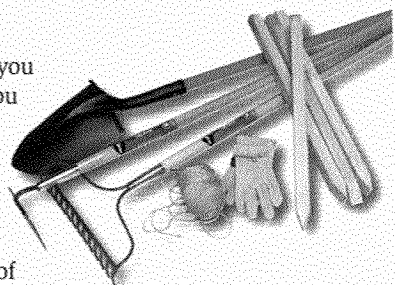

## Planning Your Garden

After you have decided what you want to grow, identify which crops grow on plants and which grow on vines. Sometimes you can plant crops that need cooler temperatures beneath the vines or stalks of a taller crop that can tolerate full sun. Or you may decide to have an ornamental garden.

Before you plant your garden, decide what crops you want to grow. (Most tree crops take two to three years or more to produce fruit and will not be discussed in this pamphlet.)

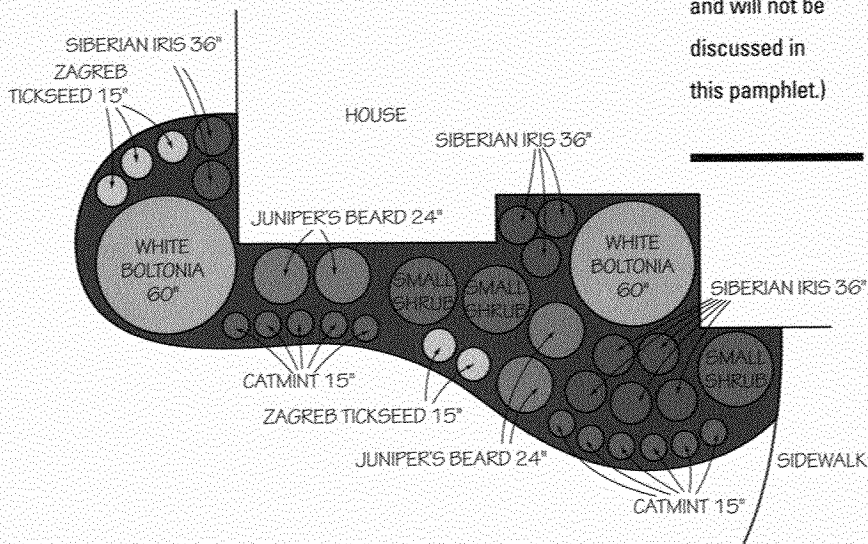

## Staying Safe While Gardening

Prevention goes hand in hand with mitigation, which means “to lessen in force or intensity” and “to make less severe.” By taking precautions to manage risk and the possibility of injury, you can be prepared to anticipate, help prevent, mitigate, and respond to just about any incident that might happen while you garden.

Like all outdoor activities, gardening has its risks. You can start by dressing appropriately for gardening—for instance, jeans, boots, gloves, and a long-sleeved shirt for protection. To ward off sunburn, frequently apply sunscreen with an SPF of at least 15. You should at least be prepared for the following.

**Minor cuts and scrapes (abrasions).** Any sharp garden tool can cause cuts and scrapes. Treat minor cuts and scrapes by flushing the area with clean water for at least five minutes to wash away foreign matter. Apply triple antibiotic ointment (if the person has no known allergies or sensitivities to the medication), then cover with a dry, sterile dressing and bandage or with an adhesive bandage.

**Puncture wounds.** Rusty nails, sharp sticks, and broken glass could cause a puncture wound. These wounds are difficult to clean and are easily infected. Help flush out dirt or particles by irrigating the area with clean, running water for about five minutes. Use sterilized tweezers to pull out small objects you can see. Do not try to remove a large, embedded object. Control the bleeding and stabilize the object with sterile rolled bandages or gauze pads, then seek medical attention.

**Heat reactions.** Help prevent dehydration by staying well-hydrated anytime you are working outdoors. Drink plenty of water—don’t wait until you feel

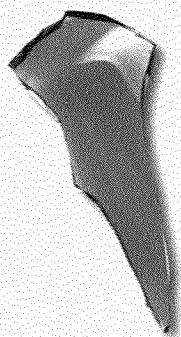

thirsty. Avoid heat exhaustion and heatstroke by taking frequent breaks indoors to cool off. If you start to feel weak, tired, faint, nauseated, or disoriented, head inside. If you don't feel better after resting, cooling off, and drinking fluids, see a doctor.

**Insect bites.** The bites of mosquitoes, chiggers, and no-see-ums are irritating but not usually dangerous. However, if your area has had cases of West Nile virus, protect yourself from mosquitoes by using the right insect repellent when you are gardening. For protection from ticks, wear long pants tucked into your boots and a long-sleeved shirt buttoned up to the collar.

Be careful when digging in areas where spiders and other biting insects might be lurking. Watch out for fire ants, which live in loose mounds of dirt. These bites can usually be treated by washing the area with soap and water, applying an antiseptic, and covering with a sterile bandage. For more relief, take a mild nonaspirin pain reliever and apply a cold pack to the area. Seek medical attention immediately if there is trouble breathing or the pain does not ease.

Anyone who is highly allergic to fire ant bites or bee or wasp stings can have a life-threatening reaction called **anaphylactic shock**, or **anaphylaxis**. Symptoms can include swelling of the throat tissues or tongue that makes breathing difficult or even impossible. **Call 911 for immediate medical assistance.** Keep the victim comfortable—usually a sitting position—until medical help arrives.

People who know they are susceptible to anaphylaxis should carry an emergency kit that contains an injection of epinephrine, a rapidly acting hormone that reverses the effects of anaphylactic shock.

For more detailed information about first aid, consult the *First Aid* merit badge pamphlet.

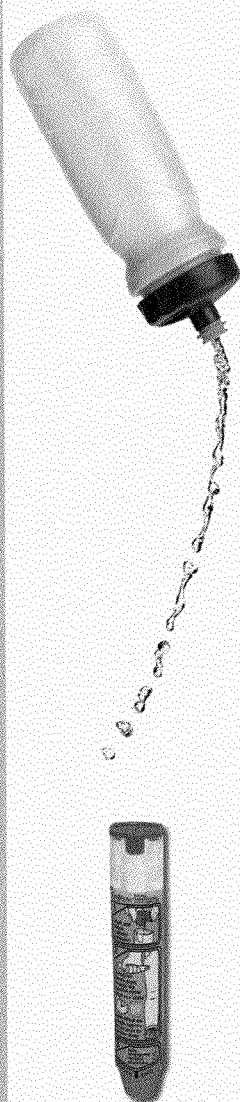

Decide where to grow the garden.

If the garden will grow in the ground, get a piece of paper and a pencil and map out where you will plant each crop. Visit the plot of land where your garden will be located and decide what you need to do to prepare the ground. You might need to till the soil and add compost or other materials, such as fertilizer, topsoil, or mulch, to make the ground ready for a garden.

If you are planning a container garden, first make a list of your crops. Then, decide how many plants you will grow and how many containers you will need. Suitable containers for patio gardens include pots made of clay, ceramic, wood, or plastic. Clean, recycled plastic containers for milk, soda, and juice also can be used.

Make sure the container has adequate drainage (cut a hole in the bottom and cover the bottom with gravel at least 1 inch deep).

You can plant several plants in larger containers, so you might need only one or two containers. Finally, figure out how much soil is needed to fill the containers.

Decide how you will start your crops. You can buy seeds or young plants at a discount store, garden center, or farmers' market. Remember that if you are growing from seeds, your garden will take longer to produce crops. The growing time is printed on the back of seed packets so you can figure out how long it will take from planting to harvest.

**A good rule to remember is to plant a seed as deep as the seed is wide. For example, a pumpkin seed is about  $\frac{1}{2}$  inch wide, so you would plant it  $\frac{1}{2}$  inch deep. Beans will be planted at a similar depth. Smaller seeds, such as pansy, marigold, and broccoli, need only a very thin layer of soil to germinate properly.**

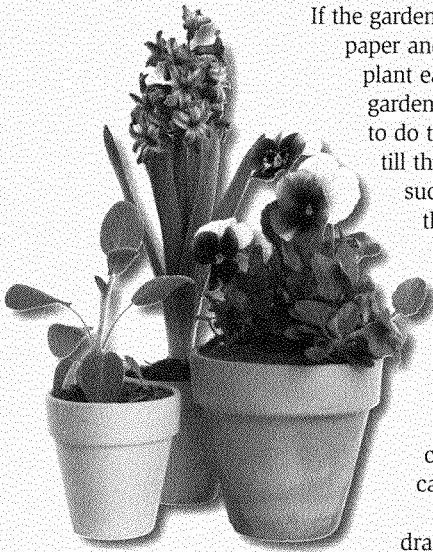

## Planting Your Garden

Growing from seed is fun because you can watch the entire life cycle of a plant. It is best to sprout—germinate—seeds indoors in small pots or from seed-starting kits. In addition, starting seeds indoors gives you the chance to see your plants several times a day. Also, you should be aware of the following disadvantages to growing directly from seed in the outdoors:

- The soil may be too hard for a young seed to sprout through.
- Rain might wash away the seeds.
- Cold weather might kill young sprouts.
- Animals, bugs, or birds might eat the seeds or young sprouts.

Your garden has a better chance of surviving outdoors if you plant seedlings that already have roots. Starting seeds indoors gives your garden a head start when the weather outdoors is still cold—about four to eight weeks before your area's last frost date. (The chart on pages 12–14 shows the average last frost dates for a number of growing regions in the United States.)

Plants are ready to set out when they have at least four leaves and remain standing when you water them. When you are ready to plant, use the map of your garden to place your plants in the areas you planned.



## Growing From Seed



You can start your garden from seed by planting the seeds in peat pots, seed trays, or small pots, or in sheets of damp newspaper.

- If you are using soil, fill containers with soil to within  $\frac{1}{2}$  inch of the top. Place one or two seeds in each container (larger containers can handle more seeds). Lightly cover the seeds with more soil.
- If you are using peat capsules, place two seeds in the circle atop each capsule, then place the capsule in a waterproof tray.
- If you are using newspaper, layer six or eight single sheets of newspaper in the bottom of a 9-by-13-inch glass baking dish. Place the seeds about an inch apart on the top layer of newspaper. Cover the paper with two additional single sheets of paper.
- After the seeds have been planted, use a mist sprayer to dampen the soil. A garden hose, sink sprayer, or watering can provides too much water pressure and will wash away small seeds.
- Place the seeds in a warm, well-lighted location.
- Keep the soil moist. Most seeds will sprout within seven to 10 days.

### Nutrition

It is important to stay physically fit. You can do this by eating healthy foods, maintaining a healthy weight, and staying physically active. Homegrown vegetables provide a lot of nutritional value.

According to the U.S. Department of Agriculture, you should consume more fruits and vegetables than any other category of food. These foods provide important vitamins and minerals that your body needs to function properly. They also provide roughage, or fiber, which is good for your digestive system.

## Show What You Grow

Exhibiting what you grow is rewarding. You can show others how hard you worked and what you learned. You might find garden contests at county and state fairs, county extension services, farmers' markets, and local garden clubs. Read the garden section in your local newspaper to

find out about garden shows. Most shows are open to the public; many allow hobbyist gardeners to enter their plants or crops in the show.

Every gardening show or contest has rules. You need to have a copy of the rules for each exhibit you prepare. These steps will help you prepare your produce for a show. After you have picked your produce:

1. Clean the produce using water and a soft brush.
2. Dry each item completely using a soft cloth or paper towel.
3. Wrap each item by itself in soft paper towels.
4. Place a 1-inch layer of packing material on the bottom of your packing box. (Plastic foam "peanuts," bubble wrap, and shredded paper work best.)
5. Place the produce on the first layer of packing material so that 1 to 2 inches of space buffers each item.
6. Fill in all the spaces with more packing material.
7. Place another inch or two of packing material on top of the produce.
8. Repeat the packing process until the box is full. (Leave enough space to add a layer of packing on top to help protect the last layer of produce.)

If you are showing a flowering plant or shrub:

1. Gently wash the leaves of the plant with water.
2. Dry each leaf carefully with a soft, lint-free cloth (clean cotton diapers or old T-shirts work well). Do not touch the flowers or buds except to remove harmful insects; the oils on your skin might cause the flower to turn brown or wilt.
3. Wrap the container in a leakproof layer of foil or decorative plastic so that it will not leak water and soil during the exhibition.



For the latest information about USDA's nutrition guidelines, with your parent's permission, go to [www.choosemyplate.gov](http://www.choosemyplate.gov).

## Anatomy of MyPlate\*

The U.S. Department of Agriculture created MyPlate to help you make better food choices and remind you to eat healthfully. Here's how.

**Balance your calories** by enjoying your food, eating less, and avoiding oversized portions.

**Build a healthy plate** by making half your plate fruits and vegetables. Make at least half your grains whole grains.

**Cut back on foods** high in solid fats, added sugars, and salt. Read and compare food labels. Avoid the extra calories by drinking water instead of sugary drinks and fat-free or low-fat milk instead of whole milk.

**Consume the right amount of calories** for your body and activity level. Using the tools found at [www.choosemyplate.gov](http://www.choosemyplate.gov) can help you make that determination.

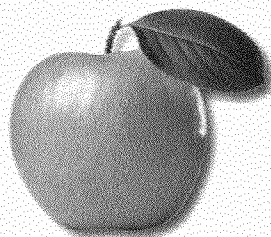
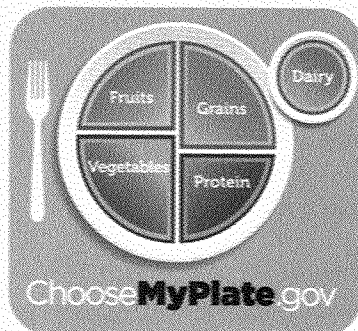

## Nutritional Value

What vitamins and minerals do fruits and vegetables provide? Here is a general guide.

### Vitamin A

Tomatoes; bananas; broccoli; yellow melons and squashes, including pumpkins; yellow, green, and red peppers; citrus fruits; sweet potatoes; zucchini; green onions; mushrooms; and carrots

### Vitamin C

Citrus fruits; dark green leafy vegetables such as spinach, collards, and kale; tomatoes; melons; peppers; cabbage; guava; strawberries; pineapples; potatoes; kiwi; and zucchini

### Iron

Dark green leafy vegetables such as spinach, collards, and kale; dried fruits; and legumes (beans, peanuts)

### Calcium

Broccoli; collards; kale; kidney, navy, and garbanzo beans; spinach; sunflower seeds; and dried figs

\*This information comes from the U.S. Department of Agriculture.



## Storage

There are many reasons to store produce after it has been harvested. The most obvious reason is so that you can eat the food later in the year, after its growing season. The two most common ways to store produce are in bins and by preserving.

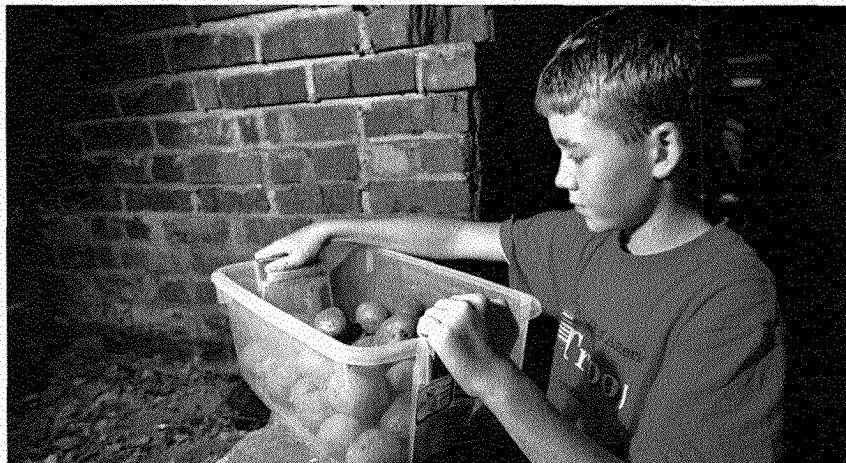

**Pack the produce loosely in bins so that air can circulate. Cover your produce with burlap or other material that will allow airflow.**

## BINS

Bin storage is good for onions, pumpkins, squash, and sweet potatoes. Basements, a cool pantry, or a closed crawl space beneath a house or other building are all good places for a vegetable storage bin. If space is tight, you can place a small, flat bin beneath a bed, as long as the space is well-ventilated and away from heating ducts. In rural areas, you can buy wooden bins at hardware, garden, or feed stores. In suburban or urban areas, you can get discarded bins from a grocery store or produce stand, or simply use a sturdy laundry basket (ask first).

## PRESERVING

Preserving means to prepare vegetables or fruit for storage by cooking or freezing. Cooked produce is usually stored in cans or jars. Canning produce is a lot of work and can be dangerous, but freezing produce can be done easily. If you would like to store your produce, contact your local extension service to get instructions. Always ask an adult to help you.



# Growing Ornamental Plants and Grasses

Ornamental means decorative, like an ornament on a Christmas tree. Ornamental trees, plants, and grasses are plants we grow because we like the way they look.

## Trees

We plant trees for two reasons: food and landscaping. Trees come in all shapes and sizes, but there are only three kinds of trees: coniferous, evergreen, and deciduous.

### Coniferous

Coniferous trees produce cones containing seeds. Examples are pine, cedar, and fir trees.

### Evergreen

Evergreen trees keep their green leaves year-round. Examples are magnolia, palm, and juniper trees.





### **Deciduous**

Deciduous trees lose all of their leaves at one time each year, usually in the fall or early winter. Examples are dogwood, oak, and pecan trees.

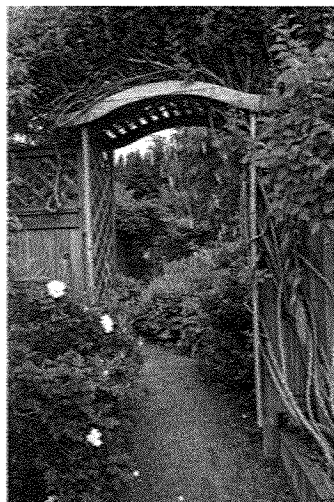

### **Shrubs, Vines, and Ground Covers**

Shrubs are smaller than trees, but larger and stronger than flowers or vegetables. Vines are plants that grow with leaves on a stem that is long and thin, like string. Some vines have soft green stems. Other vines have tough, wood stems. Vines can grow on the ground, up a tree or fence, or on a trellis. Ground covers grow low to the ground. Some grow like vines and others grow like grass. You do not mow ornamental ground covers. Some examples of ornamental ground covers include some varieties of sedum, lily turf, and Lenten rose.

For growing ornamentals, follow the germination techniques as described in the previous chapter, "Growing Fruits and Vegetables."

---

---

## Flowers

We grow flowers because they add color and beauty to our landscapes and homes. Flowers have been used to celebrate special events for thousands of years. They also are used to produce perfumes, fabric dyes, and art. Like trees and shrubs, flowers come in hundreds of shapes and sizes. But there are only two kinds of flowers: annual and perennial.



**Big-leaf  
periwinkle**

## Annuals

Annual flowers grow for one season and then die. They often provide bright flowers that grow very quickly during warm weather. Thus, annuals grow and bloom during spring, summer, or fall and die after the first frost. New ones must be planted—either from seed or young plants—every year. Some examples are impatiens, periwinkles, marigolds, and pansies. The chart at the end of this chapter is a helpful tool for planting garden annuals.

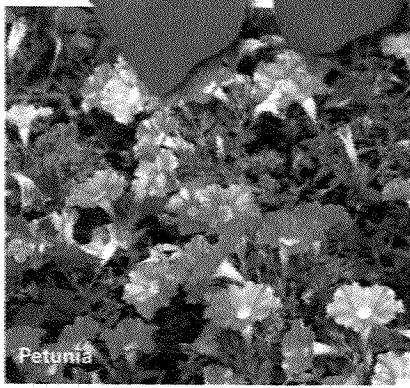

**Petunia**

## Perennials

Perennial flowers and plants come back year after year without replanting. They are like deciduous trees because they lose their leaves or die back when the weather turns cool. When the weather warms up, perennials grow back again, sometimes larger and prettier than in the prior year. They often bloom later in the warm season than annuals, but their flowers are usually larger and more impressive. Some examples are daisies, daylilies, hostas, and black-eyed susans.



**Dahlia**

## Planting and culture of selected garden annuals

Plant	When to Plant Seed	Exposure
Ageratum	After last frost	Semishade or full sun
Baby's breath	Early spring or in summer	Sun
Balsam	After last frost	Sun
Calendula	Early spring or late fall	Shade or sun
Calliopsis	After last frost	Shade or sun
Candytuft	Early spring or late fall	Shade or sun
China aster	After last frost	Shade or sun
Cockscomb	After last frost	Shade or sun
Coleus	Sow indoors anytime; outdoors after last frost	Sun or partial shade
Cornflower	Early spring	Partial shade
Cosmos	After last frost	Sun
Dahlia	After last frost	Sun
Forget-me-not	Spring or summer	Partial shade
Four-o'clock	After last frost	Sun
Gaillardia	Early spring through summer; shade in summer	Sun
Globe amaranth	Early spring	Sun
Impatiens	Indoors anytime; set out after last frost	Partial shade or deep shade
Larkspur	Late fall in South; early spring in North	Sun
Lupine	Early spring or late fall	Sun
Marigold	After last frost	Sun

Germination Time (in days)	Plant Spacing (in inches)	Remarks
5	10 to 12	Pinch tops of plants to encourage branching; remove dead flowers.
10	10 to 12	Make successive sowings for prolonged blooming period; shade summer plantings.
10	12 to 14	
10	8 to 10	
8	10 to 14	
20	8 to 12	
8	10 to 12	For best plants start early, grow in cold frame; make successive sowings for prolonged bloom.
10	10 to 12	
10	10 to 12	
5	12 to 14	
5	10 to 12	
5	12 to 14	For maximum bloom, sow several weeks before other annuals.
10	10 to 12	
5	12 to 14	Store roots; plant next year.
20	10 to 12	
15	10 to 12	
15	10 to 12	
20	6 to 8	Difficult to transplant; grow in peat pots.
20	6 to 8	Soak seed before planting; guard against damping-off (disease).
5	10 to 14	High fertility delays bloom.

Plant	When to Plant Seed	Exposure
Morning glory	After last frost	Sun
Nasturtium	After last frost	Sun
Pansy	Spring or summer; shade in summer	Sun or shade
Petunia	Late fall in South	Sun
Phlox	Early spring	Sun
Pink	Early spring through summer; shade in summer	Sun
Poppy	Early spring through summer; shade in summer	Sun
Portulaca	After last frost or in late fall	Sun
Rudbeckia	Spring or summer; shade in summer	Sun or partial shade
Salpiglossis	Early spring	Sun
Scabiosa	Spring or summer; shade in summer	Sun
Scarlet sage	Spring or summer; shade in summer	Sun
Snapdragon	Spring or late fall	Sun
Spider plant	Early spring; spring or fall	Sun
Strawflower	Early spring	Sun
Summer cypress	Early spring	Sun
Sunflower	After last frost	Sun
Sweet alyssum	Early spring	Sun
Sweet pea	Early spring or late summer through late fall	Sun
Verbena	After last frost	Sun
Vinca	After last frost	Sun
Zinnia	After last frost	Sun



Germination Time (in days)	Plant Spacing (in inches)	Remarks
5	24 to 36	Reseeds itself.
8	8 to 12	For best flowers, grow in soil of low fertility.
10	6 to 8	Does best in cool season.
10	12 to 14	Start indoors early in spring; keep cool.
10	6 to 8	Make successive plantings for prolonged bloom.
5	8 to 12	Start indoors early in spring; keep cool; remove dead flowers.
10	6 to 10	Difficult to transplant; start in peat pots; make successive plantings.
10	10 to 12	
20	10 to 14	Perennial grown as an annual; blooms first year.
15	10 to 12	Needs supports; avoid cold, heavy soil.
10	12 to 14	Remove old flowers.
15	8 to 12	
15	6 to 10	Start cool; pinch tips to encourage branching.
10	12 to 14	Reseeds freely; pinch to keep plant short; water and fertilize freely.
5	10 to 12	
15	18 to 24	
5	12 to 14	
5	10 to 12	Damps off easily; sow in hills; do not thin.
15	6 to 8	Select heat-resistant types.
20	18 to 24	Pinch tips often to encourage branching.
15	10 to 12	Avoid overwatering.
5	8 to 12	Thin after plants begin to bloom; remove poor-flowering plants.

# Nurturing Your Garden

Gardens sometimes have unwelcome visitors. You know the kind—the ones that eat or destroy plants and leave you with nothing to show for your hard work. You will need to learn how to identify and correct problems in your garden. But the best way to fix problems in your garden is to prevent them in the first place. The old saying, “An ounce of prevention is worth a pound of cure,” works for garden pests.

## Preventive Measures

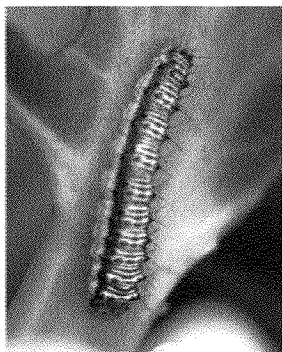

Creating a place that is unfriendly to garden pests—both insects and disease—will save you a lot of work later. The following are some ways to help prevent and discourage garden pests:

1. Use clean, well-drained soil.
2. Grow plants that are well-suited or native to your growing region.
3. Control weeds and grass in your garden.
4. Buy seeds and plants that are free of disease or insect damage.
5. Plant strong-smelling plants such as marigolds around your garden to discourage unwanted bugs, squirrels, and deer.
6. After the growing season, recycle old plants into the compost bin.
7. Destroy or properly dispose of diseased plants.
8. Do not use chemicals that will eliminate the “good” bugs in your garden.

When you are working on requirement 7, it is a good time to seek out experts to answer questions you may have about things like organic controls popular in your area.



Bees, birds, butterflies, bats, and many flying insects have something in common: They are all pollinators, vital for flowering plants and the production of many of the fruits and vegetables we all enjoy. In recent years, scientists have been concerned about the declining populations of pollinators, very likely caused by habitat loss and devastation. What can you do? Take care in using pesticides and herbicides, and make your garden friendly for pollinators with plants and trees that attract them.

## Create Your Own Wildlife Haven

If you enjoy watching wildlife, think about creating a garden friendly for the wildlife in your own backyard. Whether your garden is located on the balcony of a high-rise apartment or at a single-family home, follow these tips from the National Wildlife Federation to help attract wildlife.

- **Provide food** by planting trees, shrubs, and other foliage that produce nuts, berries, seeds, pollen, and nectar. Adding feeders and other food sources makes a garden even more irresistible for wildlife.
- **Supply water** for drinking, bathing, and reproduction. A birdbath, portable fountain, or small pond are just several ways to provide a clean water source for birds, butterflies, and other creatures.
- **Create cover** such as native plants, birdhouses (for the particular species you want to attract), and toad houses so that wildlife will have a safe haven from predators, people, and foul weather.
- **Give wildlife a place to raise their young**, such as a dense shrub, nesting box, or dead tree.
- **Let your garden go green.** You can do this by reducing lawn areas (that often require chemicals and lots of watering and maintenance), using mulch in garden beds, and replacing exotic plants with native ones.

## Be On the Lookout

Even if you practice all the preventive measures, sometimes a pest will still find its way into your garden. You will need to know what to look for and how to fix pest problems in your garden.

### Disease

Diseases in plants are a lot like diseases in people. Sometimes they are viral, like the chicken pox. Sometimes they are fungal,



## “Supercharged” Fruits and Vegetables

What if farmers could grow fields of potatoes, corn, and strawberries that could protect themselves from frost, disease, and insect pests? What if the rice you eat at dinner could protect you against blindness and reduce the risk of cancer? “Supercharged” fruits and vegetables like these are the promise of a scientific field of study called *agricultural biotechnology*.

Scientists in this field use techniques such as *genetic engineering* to create, improve, or modify plants, animals, and microorganisms, according to the U.S. Department of Agriculture (USDA). Genetic engineering is the process of “cutting and pasting” genes within one species or from one species to another. So, for example, a gene that protects a plant against early frosts can be inserted into strawberries; or a gene that increases crop yield can be added to corn, so that a farmer produces a bigger crop than usual.

Some “supercharged” fruits and vegetables already exist and have been tested and approved by the USDA’s Animal and Plant Health Inspection Service. A few examples include insect-resistant potatoes, corn, and cotton, and longer-lasting tomatoes. And experiments continue, so that one day wheat will grow in fields that are now unfavorable to the crop and bananas will contain edible vaccines.

like athlete's foot. And sometimes they are bacterial, like a cavity in a tooth. Most stem, leaf, flower, and fruit diseases are caused by viruses, bacteria, and fungi. Most root or soil-borne diseases are caused by fungi.

Bacterial diseases are caused by single-celled organisms that feed on plants to survive. The host plant becomes diseased because the bacteria take nutrients from and cause damage to the plant's structure. You can control bacterial diseases with bacterial soaps made specifically for the garden. These soaps kill the harmful bacteria without harming beneficial insects.

Fungal diseases are caused by multicelled, threadlike organisms called fungi. Fungi grow and produce spores, or new cells, that spread with wind, insects, or water. Fungal infections damage the plant structure. Once weakened by fungal infection, a plant becomes vulnerable to other diseases. To prevent fungal disease from infecting your plants, pick off dead or dying leaves and use clean garden tools. Planting fungus-resistant plants and using antifungal sprays and soaps also help control disease.

Many types of plants have varieties that are resistant to fungus. Check the seed packet or the identification stake that comes with prestarted plants in the garden center. A fungus-resistant plant will be listed as "resistant to powdery mildew" or "resistant to gray mold."

Viral diseases spread among plants the same way they spread among humans. Plants infected with viral diseases grow deformed leaves, flowers, and produce, and might change color. Viral diseases are difficult to control. In most cases, the affected plant must be removed from the garden and destroyed.

---

Sometimes, plants become diseased because of environmental problems: pollution and too much or too little sun, nutrients, or water.

---

## What to Do With Infected Plants

If you have to remove a diseased plant from your garden, you should destroy it. This prevents the disease from spreading to other plants. You can dispose of infected plants by burning them, but that might require a local permit. An easier and safer method of disposal is to place the affected plant in a plastic garbage bag, seal it, and put the first bag into a second plastic bag. Seal the second bag and place it into the household waste bin for the waste company to remove.

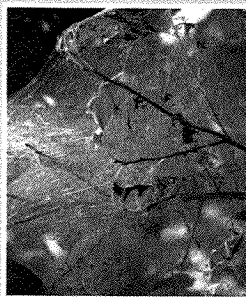

The most common environmentally based diseases are chlorosis and soil salinity. Chlorosis is caused by a lack of iron in the soil. Soil salinity results when overwatering and overfertilizing leave too much salt in the soil. Both problems can be corrected with readily available organic or synthetic soil additives.

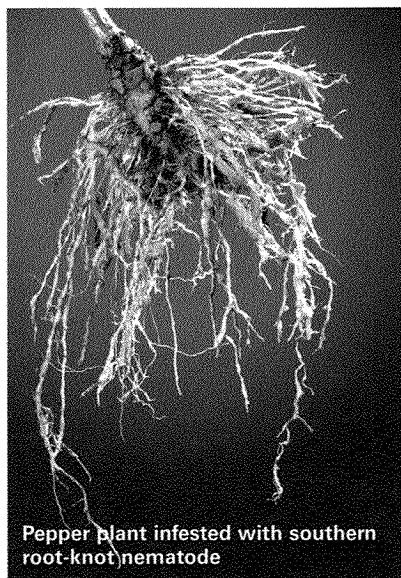

Pepper plant infested with southern root-knot nematode

## IN ROOTS

Root diseases are the hardest kind of plant problems to detect and correct. The plant might wilt or die completely, without an obvious cause. When a plant becomes sick or dies from root disease, it is usually caused by water mold fungi that are too small to see with your eyes, or by immature insects, called grubs or larvae.

If you suspect root disease, soak the area with diluted dish soap. (Mix 1 tablespoon of dish soap with 1 gallon of water, adding the soap to the water to reduce foaming.) Grubs will surface within a few minutes. You can see grubs with your eyes. If you do not see any grubs, then a fungal infection is likely the cause. Gently dig an inch or two

deep around the base of the affected plant.

If there are no signs of grubs, remove the affected plant from your garden and destroy it.

## Garden Pests

Here are some common pesky garden critters that need to be controlled.

- Aphids
- Cabbage maggots
- Caterpillars
- Colorado potato beetles
- Cutworms
- Flea beetles
- Japanese beetles
- Mealybugs
- Mexican bean beetles
- Scale insects
- Tarnished plant bugs

Croton caterpillar

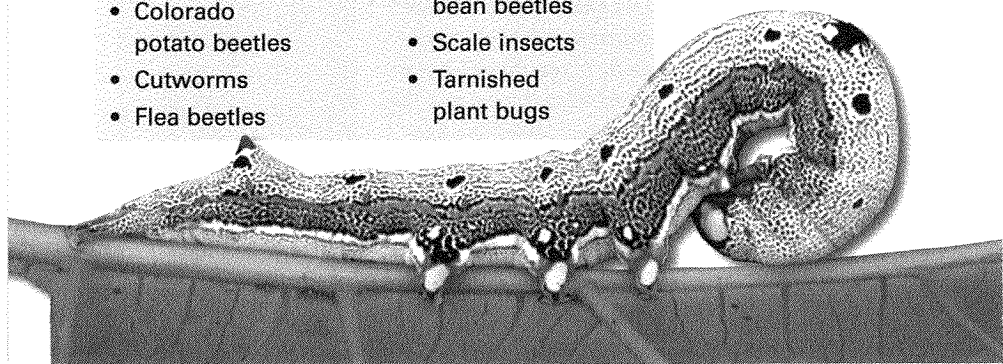

## ON LEAVES

Problems on leaves are easier to see, because of the physical evidence: a chewed leaf, spider web, or bug droppings. Sometimes yellow leaves are the only symptom, but yellow leaves are usually caused by a root disease, not a leaf disease.

The safest way to control harmful insects in your garden is to pick them off (using gloves) and destroy them. You can use insecticidal soaps or sprays, but they often kill the good bugs as well. Yellow leaves might indicate what is called iron chlorosis. You can easily repair this problem by adding iron to the soil.

Your local garden center or extension service will be able to help you diagnose plant diseases. Follow these steps to obtain a sample of the problem:

- Step 1**—Using a resealable plastic bag, capture the sample fresh from your garden.
- Step 2**—Open the bag and gently place it around an infected leaf or group of leaves.
- Step 3**—Try to catch at least one insect, if possible.
- Step 4**—Seal the bag on both sides of the stem, then clip the stem.
- Step 5**—Push the stem into the bag.
- Step 6**—Seal the bag completely.
- Step 7**—Take the sample to your garden center or extension service as soon as possible so the sample remains fresh.
- Step 8**—Follow the instructions provided by the agricultural professional.

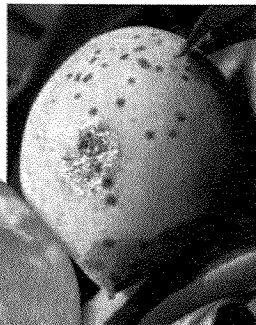
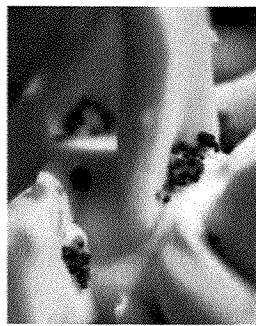
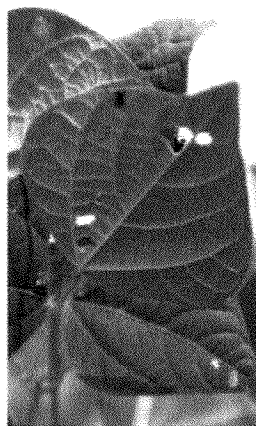

## ON VEGETABLES OR FRUITS

Like leaf problems, disease or insect damage on produce is easy to see. The vegetable or fruit will have holes or soft spots on its skin. It is best to remove the damaged produce from the plant and dispose of it. Do not eat fruits or vegetables that have obvious insect damage.

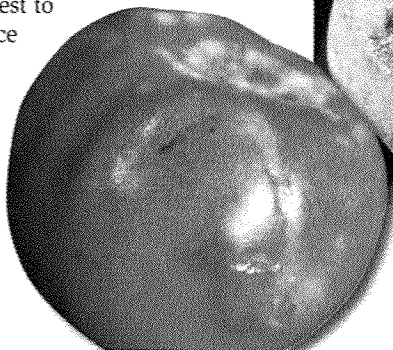

## Help Your Garden Grow

Many people think that *all* bugs are harmful, but this is not true. Some bugs are fun, and some bugs are very important members of our garden families. Good bugs pollinate our gardens and eat the bugs we do not want there. Unwanted bugs eat, damage, or destroy garden plants. Diseases also attack the plants. It is important to know how to control all types of pests in your garden.

### Organic Controls

Organic controls are natural methods of garden management that do not harm the environment. Many inorganic controls contain toxic chemicals that kill beneficial insects, birds, and other wildlife. They also can leave harmful chemicals on the food we eat. By using organic garden practices, such as soil building, composting, plant care, and preventive pest control, you can create a garden that needs little "outside" help.

## Organic Controls

The benefits of using organic controls include the following:

- **Cultural controls** reduce the number of pests by keeping the plants healthy and the garden clean.
- **Biological controls** reduce the number of pests by using living creatures, such as birds, beneficial bugs, and microbial sprays, to control insects and plant diseases.
- **Physical controls** keep pests away from your garden by using barriers or by removing them by hand.
- **Organic chemical controls** use chemicals that occur naturally in plants or minerals. These chemicals break down more quickly and have fewer toxic effects on the environment. They are used by organic gardeners only as a last resort.



## BENEFICIAL BUGS

One of the easiest ways to control pests in your garden is to let nature take its course. As you know, within the food chain small creatures fall prey to large creatures. The same principle can be applied to your garden. Let the good bugs eat the bad bugs and you won't have to spend time picking and squashing the bad bugs. The following list describes beneficial—good—bugs that you can invite into your garden to help control insect damage.

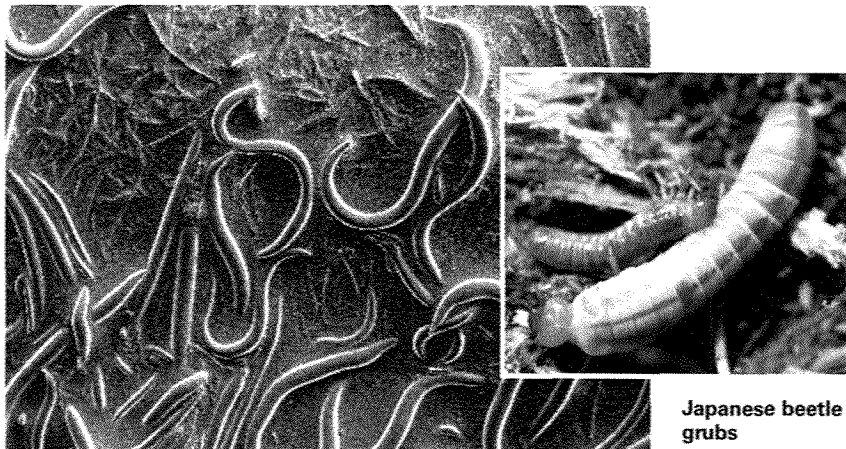

**Nematodes**

**Japanese beetle grubs**

- **Nematodes** are little wormlike parasites that feed on grubs and bad worms in the soil, such as Japanese beetle grubs, root weevils, wood-boring caterpillars, armyworms, and billbugs.
- **Green lacewings** produce the hungriest babies in the bug world. Their larvae have huge appetites for aphids, other small insects, insect eggs, and spider mites.
- **Parasitic wasps**, like the tiphia wasps, will not bother people or pets, but they do destroy garden pests. They reproduce by laying eggs in a host insect or insect egg, generally those of aphids, whiteflies, cabbage loopers, and hornworms. The larvae then eat the host, thereby removing the pest from your garden.



The red ladybug makes a good garden resident.

- **Syrphid fly** larvae eat aphids, mealybugs, and small insects like gnats. Adults are often called hover flies because they hover over nectar-producing flowers. They do not sting. Sometimes, they are large enough to be confused with a small hummingbird.
- **Red ladybugs**, or lady beetles, eat mealybugs, aphids, and young scale insects. Orange lady beetles, however, are destructive to many garden flowers.
- **Ground beetles**, sometimes called black beetles, eat dirt bugs—the kinds of insects and pests that make their homes in your flowerbeds, lawn, and patio containers. Ground beetles eat cutworms, root maggots, slugs, and snails.

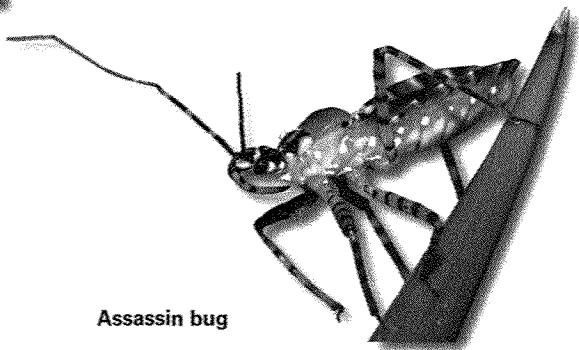

Assassin bug

- **Assassin bugs** eat flies, mosquitoes, beetles, and large caterpillars. They have horns. They bite. They squeak. They hatch in June. They are not very “nice” bugs, but they eat the bad guys. They are aptly named.
- **Tachnid flies** love Queen Anne’s lace, dill, and parsley. They also will munch on most any bad caterpillar, as well as gypsy moth larvae.
- **Rove beetles** are those little black or brown bugs that skittle away when you clear away mulch or pine straw to plant an annual or yank a weed. They look like little scorpions because they keep their abdomens pointed upward while they move. Rove beetles eat aphids, spring-tails, mites, slugs, snails, fly eggs, and maggots. They are also little compost machines, eating and breaking down decaying organic material.

## Attract Butterflies to Your Garden

Besides being pretty and fun to watch, butterflies help pollinate your garden. You can attract butterflies by growing plants and flowers that contain a lot of nectar. Some nectarous plants are azalea, black-eyed susan, catnip, daisy, goldenrod, lilac, marigold, honeysuckle, zinnia, and, of course, butterfly bush.

If you grow plants on which butterfly larvae (caterpillars) feed, called larval plants, butterflies will take up residence in your garden. Some larval plants are aster, clover, dill, fennel, milkweed, nasturtium, parsley, snapdragon, sorrel, verbena, and violet. You will notice leaf damage where the larvae have fed, but the damage is temporary and usually minor.

Different butterflies feed on different plants during the larval stage. For example, monarch butterflies feed on milkweed, swallowtail butterflies feed on parsley, and American copper butterflies feed on sorrel. By planting a variety of larval plants, you can increase the variety of butterflies in your garden.



Baltimore butterfly

Lastly, do not forget one of the best garden friends of all, the toad. Toads eat just about all bugs, good or bad. In general, toads are welcome in gardens because most of them are harmless and there usually are more bad bugs than good bugs in any garden. You can encourage a toad to move into your garden by providing it a home.

Toad houses are garden accents that look like upside-down clay pots with little doors. Some even have windows and chimneys. You can make one by burying a clay pot halfway, on its side, so there is room enough for a toad to move into the house.



## COMPANION PLANTING

Companions are friends. Friends help each other. Certain kinds of plants can help each other. Planting marigolds, garlic, or other herbs is a common way to control garden pests. Companion plants can protect crops by producing an odor that repels pests. Many kinds of companion plants, such as dill, are nurseries for larvae of beneficial insects. (Butterflies lay eggs in dill, then the larvae eat the eggs. Talk about a protein-rich breakfast!)

Some plants distract deer, squirrels, and other furry friends who use flowerbeds and gardens as a walk-through restaurant. Deer would rather eat soybeans and buckwheat than azaleas and roses. Marigolds contain pyrethrin, which is the chemical most commercial flea sprays use to ward off the pet-prone pests. Pyrethrin is one of the few chemicals permitted in organic gardens. Squirrels, mice, and other vermin dislike the chemical as much as they do fleas.

## Come Play in My Garden

These plants will attract beneficial garden creatures.

Angelica	Marigold
Bee balm	Parsley
Buckwheat	Peony
Calendula	Peppermint
Candytuft	Queen Anne's lace
Chinese cabbage	Rudbeckia
Cilantro	Spearmint
Clover	Sunflower
Daisy	Sweet alyssum
Dill	Thyme
Evening primrose	Valerian
Fennel	Yarrow



## Rank and Smelly Sulfur

Farmers have been using sulfur for hundreds—perhaps thousands—of years to repel garden problems. It decreases the pH of alkaline soils, which repels some pests, including fungi and mites. Snakes are particularly repelled by its odor. Sulfur might harm beneficial bugs, so use it as a last resort to kill fungal diseases, and under close adult supervision.

### INSECTICIDAL SOAPS AND WASHES

Bugs sometimes leave behind droppings, which attract more bugs. One way of controlling unwelcome bugs in your garden is to use a natural insect soap. And don't forget: Spiders build webs that catch dirt and insects, too.

Insecticidal soaps are specially made solutions of fatty acids that kill insects like aphids, mites, and whiteflies. The soap paralyzes the insect, which will then die of starvation. It must be applied every two to three days during an infestation. You can buy prepared insecticidal soaps, but many organic gardeners use a mixture of 1 to 3 tablespoons of gentle dish-washing soap (not detergent; read the label to be sure) per gallon of water in their garden sprayer.

### Inorganic Controls

The most important thing to remember about inorganic, or synthetic, pest controls is that they are dangerous and toxic. The poisons they contain are harmful to your family, your pets, good bugs, wildlife, and the water supply. When used incorrectly, they can affect streams, rivers, ponds, and lakes. Always ask an adult to help you correctly and safely use pesticides, fungicides, and fertilizers. Start by reading the label on the container or package and closely following the manufacturer's instructions.

For example, caterpillars are not good for a vegetable garden, but the butterflies they become are helpful for a flower garden. If you kill the caterpillars, you are killing the butterflies. Before using an inorganic control, you might consider companion planting dill or milkweed to give the caterpillars something to munch on instead of your vegetables.



Always carefully read the label on all pesticides, fertilizers, and other garden treatments. Follow the manufacturer's instructions, and use these chemicals only under close adult supervision.

## PESTICIDES

Pesticides, also called insecticides, are chemical mixtures that kill bugs. Properly used, they provide quick, effective ways to control insects and disease in your garden. Improperly used, they can make you very sick.

Each pesticide is required by federal law to contain a label that lists the diseases or insects for which it should be used, the plants on which it should be used, the ingredients it contains, and safety precautions. Many states further regulate the use of some pesticides. It is illegal to apply pesticide to a plant or pest not listed on the label.

When no other means of pest control has worked, you may choose to use a synthetic pesticide as a temporary means to control a serious infestation. A healthy natural environment is a balanced system. A diverse garden contains the plants and natural controls that should maintain this balance. When it does not, pests invade and damage begins. Here are some commonly used pesticides.

**Azadirachtin.** Used for insect control and some fungal diseases like black spot and powdery mildew.

**Propoxur.** Used in earwig baits and wasp spray, but unsafe for use on edible plants, fruits, and vegetables.

**Bacillus thuringiensis (called Bt).** Paralyzes and disintegrates the stomachs of the insects it destroys. It is poisonous to caterpillars, mosquitoes, and some beetles.

**Contact dusts.** Powders that cling to the outside of plants and typically suffocate insects that come into contact with it.

Boric acid and diatomaceous earth are the most commonly used dusts. All are harmful if inhaled.

**Diazinon.** The only chemical control for soil pests in gardens. Unfortunately, this chemical also kills lightning bug larvae, bees, and birds. Use it sparingly, if at all.

### STORAGE AND DISPOSAL

**Storage:** Use and store this product only in its original container or open flame. Store product in a secure storage area away from sources of heat and container, securely wrap original container in several layers of newspaper and discard in trash.

**Dispose:** Do not reuse product from freezing. To dispose of unused product, discard in trash.

**Spill or leak:** In case of spill or leak, soak up with paper towels and discard in trash.

### PRECAUTIONARY STATEMENTS

**Hazards to Humans and Domestic Animals**  
**CAUTION:** Harmful if absorbed through the skin. Causes moderate eye irritation. Avoid contact with eyes, skin or clothing. Wash thoroughly with soap and water after handling. Keep children and pets away from treated areas until spray has dried. Avoid contamination of food. Do not contaminate water supplies.

### FIRST AID:

**If on Skin:** Take off contaminated clothing. Rinse skin with plenty of water for 15-20 minutes. Call a Poison Control Center or doctor for treatment advice.  
**If in Eyes:** Hold eye open and rinse slowly and gently with water for 15-20 minutes. Remove contact lenses, if present, after the first 5 minutes, then continue rinsing eye. Call a Poison Control Center or doctor for treatment advice.  
 Have the product container or label with you when calling a Poison Control Center, doctor or going for treatment.

### Environmental Hazards

Do not apply directly to water. Do not contaminate water when disposing of equipment washwaters.

**NOTICE:** Buyer assumes all responsibility for safety and use not in accordance with directions.

MADE IN THE  
**USA**  
 Division of United Industries Corp.  
 P. O. Box 142842, St. Louis, MO 63114-0042  
 EPA Reg. No. 67760-69-9689  
 EPA Est. No. 36889-AAD-1  
 99m 3110

**Fungicides.** These are dusted or sprayed onto foliage to kill or prevent fungal diseases. Some fungal diseases include powdery mildew, rust, black spot, leaf spots, and azalea petal blight. Ingredients of fungicides include captan, triadimefon, triforine, calcium polysulfide, sulfur, and chlorothalonil.

**Malathion.** A broad spectrum pesticide commonly used on vegetable and ornamental plants. It is toxic to bees.

**Oil sprays.** These smother insects that come into contact with them. They are helpful for controlling aphids, scale insects, and mites. Use carefully on tender young leaves and flowers, as the oils can burn the tissues.

**Pyrethrins.** Natural insecticides derived from the *Pyrethrum* daisy. Marigolds also contain pyrethrins. In sunny areas, pyrethrins break down in a few hours. They are the main ingredient of most flea sprays, powders, and collars. They are also effective against flying insects.

**Rotenone.** An insecticide used to control chewing insects on vegetables. It is highly toxic to fish.

**Carbaryl.** Commonly used in vegetable gardens to thwart chewing insects. It is not effective against sucking insects, and often destroys their natural predators. It is highly toxic to earthworms and honey bees.

**Systemic pesticides.** Absorbed by plant roots or leaves and are effective on insects that eat either. Systemic pesticides are not safe for use on edible plants, fruits, and vegetables.

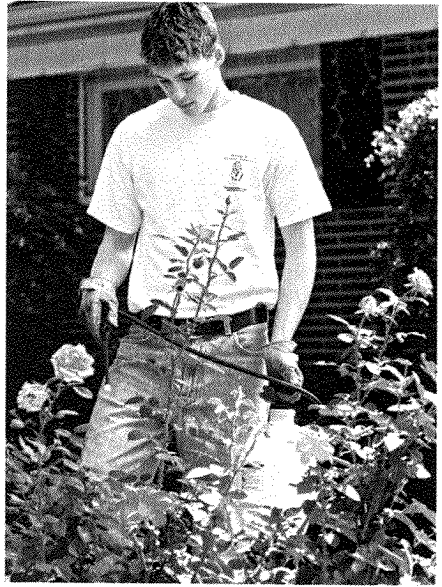

---

Avoid inhaling chemicals—doing so can damage your airway and lungs, too.

---

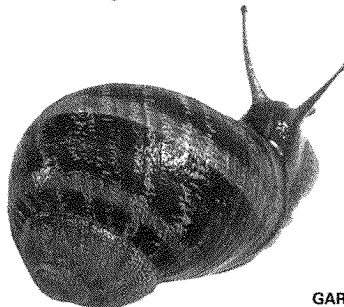

## Garden Chemicals: Think Safety

- Read the label and follow the manufacturer's instructions.
- Use pesticides, fungicides, and fertilizers only under close adult supervision.
- Keep all pesticides, fungicides, and fertilizers in original containers.
- Never combine pesticides, fungicides, or fertilizers.
- Store chemicals tightly closed, away from food, and out of the reach of children and pets.
- Wear protective gloves, clothing, an air mask, and safety glasses when preparing and applying chemicals.
- Wash your clothing, skin, containers, and sprayers thoroughly after you have finished.
- Stay out of treated areas until the spray is dry or the dust has settled. Keep pets and small children out of the area.

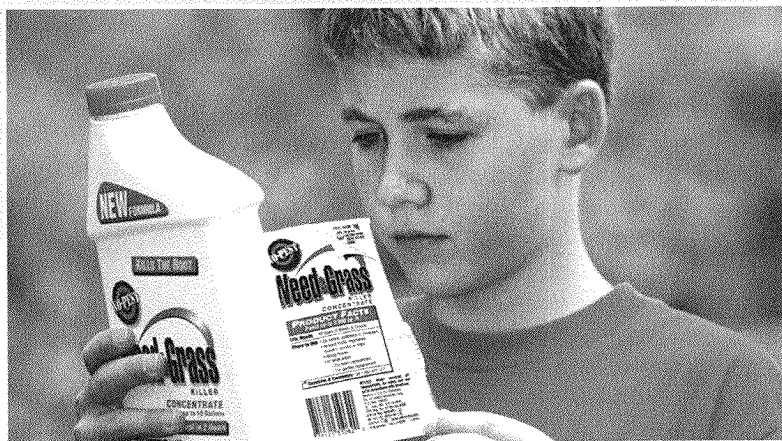

A chemical burn might not be immediately noticeable. However, as long as the dry chemical is on the skin, it will continue to burn. Quickly brush off as much of the chemical as possible using a gloved hand. Dilute the exposure by continuously flushing the area with water for at least 15 to 20 minutes and seek medical attention. For more information about chemical burns, see the *First Aid* merit badge pamphlet.



## Feeding Your Garden

Like you, your garden needs food to grow strong and healthy. Food for your garden is called fertilizer, which can be dry or liquid.

Dry fertilizers come in pellets, tablets, stakes, or powders that you spread by hand or using a mechanical spreader (handheld or pushed). They are usually time-released, meaning that they release a little bit of their nutrients with each watering or rain shower. It is important to spread dry fertilizer lightly and evenly, or you could harm the plants you are trying to feed. Dry fertilizers work best for large applications, such as trees, a yard, or a large garden or farm.

Liquid fertilizers are mixed with water and are poured or sprayed onto foliage or around the plant's base. Liquid fertilizers provide the plant with quick and easy-to-absorb nutrients. Because they are diluted, there is little chance of harming tender foliage. Liquid fertilizers work well for container plants, water gardens, and small garden plots.

Dry and liquid fertilizers include the following:

- **Complete fertilizers** contain all of the primary nutrients: nitrogen (N), phosphorus (P), and potassium (K). These nutrients are described later in this section.
- **Special-purpose fertilizers** contain nutrients for a particular kind of plant. You might see fertilizers labeled "African violet food" or "camellia food," specially mixed with the nutrients these plants need most. Special-purpose fertilizers also can contain one or two of the primary nutrients. Simple fertilizers contain only one of the primary nutrients.
- **Organic fertilizers**, made from the decayed remains of living organisms, include blood meal, manures, composted yard waste, organic humus, and worm castings.

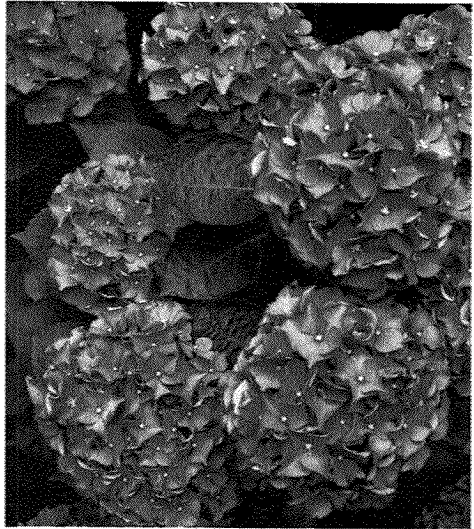

**Hydrangea**

---

Just like pesticides and fungicides, inorganic and synthetic fertilizers are toxic and dangerous, and require special handling. You should observe the same safety precautions with synthetic fertilizers.

---

### WHAT DO THE NUMBERS MEAN?

Fertilizers are complex mixtures of the different nutrients plants use. There are many kinds of fertilizers for many kinds of gardening. All fertilizers have at least one thing in common: the number system used to measure the nutrients in the product. The higher the number, the more nutrient in the fertilizer.

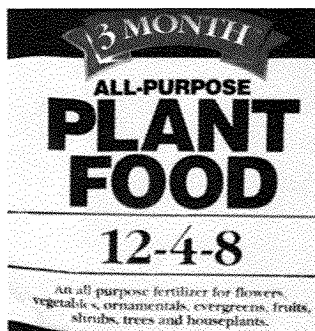

- The first number measures nitrogen (N). Nitrogen helps plants grow lots of healthy foliage. It is also the nutrient that all plants need to survive. A plant with a nitrogen deficiency might have stunted growth, yellow leaves, or an overall light green color when it should be dark green.
- The second number measures phosphorus (P). Phosphorus helps plants, especially lawns, develop strong root systems.
- The third number measures potassium (K). Potassium is the energy booster that helps annual and perennial plants produce a lot of flowers or vegetables. Along with nitrogen, potassium helps make grass and plants a deep green color.

For example, take a mixture of 20-20-20. This fertilizer contains 20 percent of each primary nutrient. It is called an all-purpose fertilizer because it provides equal amounts of all primary nutrients. The types of plants and soil you have will help you determine which fertilizer to use.

### ORGANIC AND HOMEMADE FERTILIZERS

Many gardeners prefer to make their own fertilizers. Organic and homemade fertilizers are derived from natural things like decaying plants, food, and earthworm castings. Because these fertilizers do not

add synthetic chemicals into the soils or plants, many gardeners believe this is a healthier way to garden. This section describes organic and homemade fertilizers, as well as how to construct compost and vermipost bins.

**What Is Composting?** Composting is the recycling of organic matter like grass clippings, leaves, and raw kitchen waste (no cooked foods!) such as fruit and vegetable peelings, apple cores, and eggshells. Compost bins are easy to make and use.



**Commercial  
compost bin**

Find a suitable location in your yard to place the bin. Most gardeners keep compost bins in an area that receives full sun and is convenient to their garden. This ensures that the bin maintains a constantly warm temperature year-round. Once you have found a sunny location for your compost bin, collect the supplies listed below. Ask an adult to help you with this project because the compost bin materials are heavy and bulky for one person to hold.

To build your compost bin, gather the following supplies:

- Four wooden pallets
- 54 wood screws or wood nails
- One hook-and-eye latch (the kind used for screen doors)
- Six corner brackets (as shown in the illustration)
- Three hinges (as shown in the illustration)
- Heavy plastic sheeting (if you live in a dry climate)
- Weed matting (a woven plastic material)
- Brown dry items, such as leaves, dried hay, and dried grass clippings
- Green wet items, such as fresh grass clippings and raw kitchen waste (no meat or dairy products)
- Water (preferably from a garden hose)

Complete these steps to build and fill your compost bin. You can bury kitchen scraps as you go, but make sure all kitchen scraps are buried deep in the pile to keep animals and insects from digging them up.

**Step 1**—Using the corner brackets as shown, screw or nail three of the pallets together at three points on each side.

**Step 2**—Attach the hinges to the front edge of the bin so that the fourth pallet swings like a door.

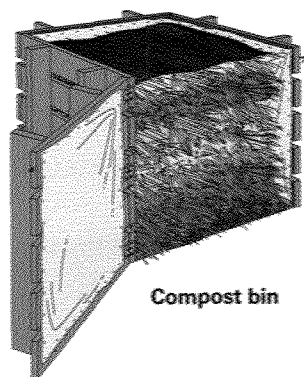

Compost bin

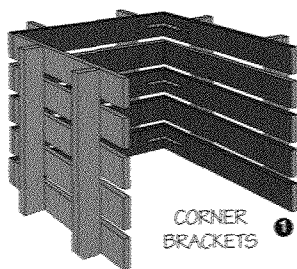

CORNER BRACKETS 1

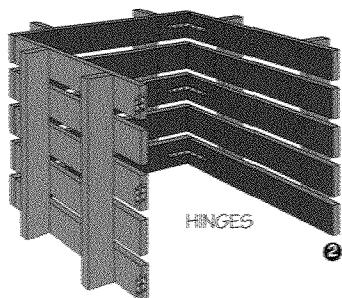

HINGES 2

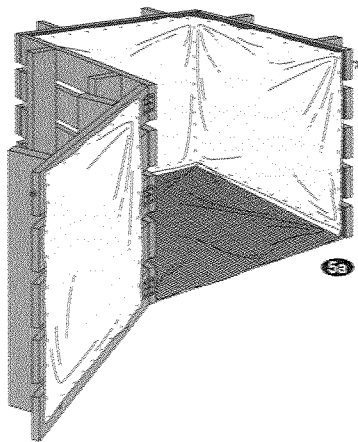
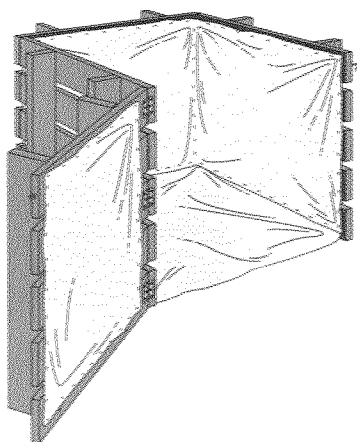
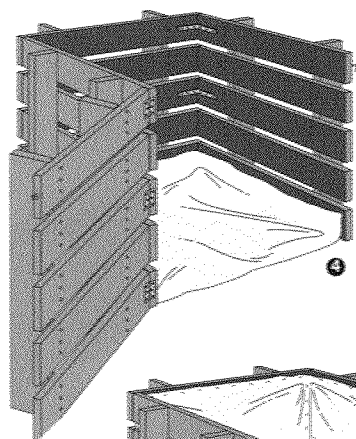
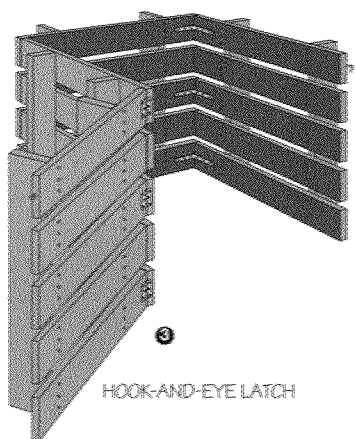

**Step 3**—Attach the last pallet to the bolt hinges to make a door. Then attach the hook-and-eye latch that will secure the door in place.

**Step 4**—In dry climates, line the bin with heavy plastic sheeting to maintain moisture levels and temperatures. Staple a sheet of plastic to the three sides of the bin. Use a separate plastic sheet for the front door.

**Step 5**—Once your bin is stable and in its permanent location, fill your compost bin with ingredients from the top in the following order:

- a. Place a layer of weed matting on the bottom of the bin. This will help prevent weeds, keep out fire ants, and aid in drainage.
- b. Add a 3-inch layer of hay, straw, or broken sticks and twigs over the weed matting to cover the entire bottom of the bin. This creates a drainage area.
- c. Add a layer of brown waste, then a layer of green waste, and another layer of brown waste.

- d. Continue layering in the following order until the bin is full or you have added all the waste: (1) sticks or hay, (2) brown layer, (3) green layer, and (4) brown layer.

When the bin is full, soak it with the garden hose. The entire pile should feel like a wet sponge when you touch it. Cover the inside of the bin with another layer of weed matting, then secure the cover of the bin by laying large rocks on it. Have an adult help you attach the cover to two corners of the top of the bin. Stapling or nailing the cover will help secure it during bad weather.

Using a shovel, hard rake, or pitchfork, till (turn over) the contents of your bin once a week. When you have turned the pile, hold your bare hand near the center of it. You should feel heat rising from the pile. In the winter, you might see steam emerging as you till. This heat means your pile is composting well. A cool pile will need more green waste or water to get it going.

Add new ingredients and water when you till. Your compost should be ready in three to six months.

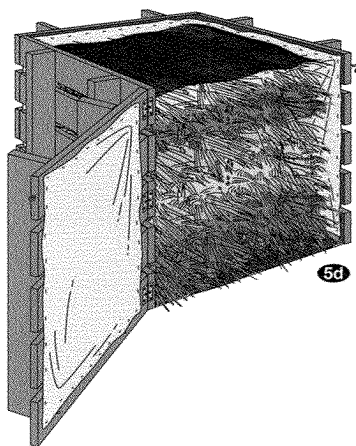

## How Green Is Your Garden?

When you create a garden, you make many choices: What kind of pest control and fertilizer will you use, if any? What kinds of plants will you include?

“Stewardship gardening,” “green gardening,” “environmental gardening,” and “sustainable gardening” are all terms that refer to the same basic ideas and goals. That is, how can people grow the garden they would like, but at the same time do as little damage to the environment as possible?



---

**Tip:** Remember not to include cooked foods, raw or cooked meat, or dairy items, because they cannot be composted successfully.

---



Here are some of the ways you can help preserve natural resources as you garden.

- Whenever possible, use electric or manual lawn equipment instead of those with gasoline engines. Using a gasoline-powered lawnmower for an hour produces the same amount of pollution as driving a car 100 miles.
- Choose hardy plants suitable for your region. Such plants will have more natural resistance to local pests, and therefore need less pesticide.
- Make your own compost. You are recycling what would have gone into the trash, and creating your own fertilizer instead of purchasing it.
- Plant trees. In addition to emitting fresh oxygen and controlling soil erosion, well-placed trees can shade your home in summer and buffer the cold winter winds.
- Plant natural pesticides such as garlic and marigolds. Let beneficial insects such as ladybugs fight your plants' enemies.
- Conserve water. Use mulch (but not Cypress mulch) to keep soil moist. Water plants (preferably very early in the morning) with a soaker hose to reduce water waste and evaporation.
- Make a happy home for wildlife. Birds, butterflies, and other critters are being pushed out of their natural homes as humans intrude on their habitats. Your garden could provide a much-needed refuge.



**What Is Vermiposting?** A vermipost is a worm bin filled with—you guessed it—worms, and is maintained by gardeners to generate organic compost. Vermiposting is a bit more complicated than composting. But even with the extra work, it can be a lot of fun to watch worms recycle your kitchen waste. Worm castings are highly prized by organic gardeners as a potent, natural fertilizer.

You will need 1 square foot of surface space in your vermipost bin for each pound of waste. To determine how large your vermipost bin should be, measure the kitchen waste your family produces for one week. Collect raw vegetable and fruit peelings, coffee grounds, and egg shells in gallon-sized airtight plastic bags (zipper freezer bags work best). Store the waste sealed in the bags in the refrigerator for one week. Use a standard bathroom scale to weigh your collection at the end of the week.

To help meet the merit badge requirements, you may reduce the size of your vermipost bin to compost half the weight of your family's weekly waste amount. If the weight is 5 pounds, build a small vermipost bin to compost 2.5 pounds of waste. You can increase the bin's size later on.

Once you have determined the size of bin, gather the supplies listed below:

- Plastic or wood container, at least 8 inches high by 12 inches wide and 18 inches long
- Shredded newspaper
- Clean builder's or sandbox sand
- 1 to 2 pounds of red wiggler worms (purchase from organic gardening centers, the internet, or mail order catalogs)
- 5 pounds of unbleached, unpainted aquarium gravel
- Tray to catch drainage

Follow these steps to build your vermipost bin.

**Step 1**—Punch holes in the sides and ends of the container to allow air to circulate. Holes should be about 2 inches above the bottom. Punch three small holes in the bottom of the container to catch any drainage.

**Step 2**—Layer 2 inches of the aquarium gravel in the bottom of the container. This ensures drainage.

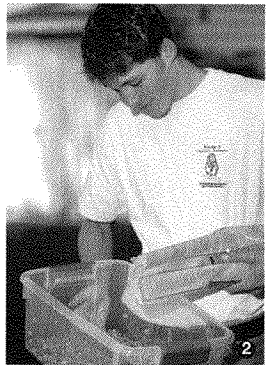
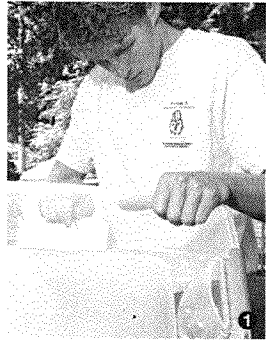



**Step 3**—Tear black-and-white newsprint into 1- and 1½-inch strips. Do not use colored newsprint, advertisements, or magazine print. The dyes used in the inks are toxic to worms and will kill them.

**Step 4**—Moisten the strips with water and mix them with a few handfuls of sand.

**Step 5**—Fill the container three-quarters full with the mixture.

**Step 6**—Buy 1 to 2 pounds of red wiggler worms. These worms are a kind of earthworm specifically adapted to eating rotting vegetable matter. Other kinds of worms will not perform this kind of composting. You can buy red worms at organic garden centers and through the internet or mail order catalogs (with your parent's permission).



**Step 7**—Place the red worms, soil and all, in the container.

**Step 8**—Add approximately 2 inches of dry shredded newsprint and cover the container with a solid plastic or wood cover.

**Step 9**—Feed the worms once or twice a week by pulling up some of the mixture and burying waste in small holes at different locations in the bin. Do not feed the worms if they have not finished their last meal. Overfeeding causes the food waste to sit around too long, which creates a foul odor and attracts flies and gnats. If you overfeed the worms, stop adding food waste until the worms have composted what is already in there.



Five pounds of kitchen waste would equal 5 square feet of surface area in a vermipost bin. The bin would need to measure at least 12 inches wide and 5 feet long to accommodate enough worms to consume all that waste!



**Step 10**—Find a warm location where the temperature will remain between 55 and 85 degrees. Colder or hotter temperatures may kill the worms. The crawl space beneath a house or a shady corner of the yard are good locations for vermipost bins during the spring, summer, and fall. In the winter, vermipost bins should be moved indoors to the basement or other unused space.

**Step 11**—Place your bin on top of the blocks on the drain tray.

**Step 12**—Empty the drain tray into a bucket as needed. Save the juice in an old milk container or plastic soda bottle. You can mix this juice with water to make liquid fertilizer for your garden.

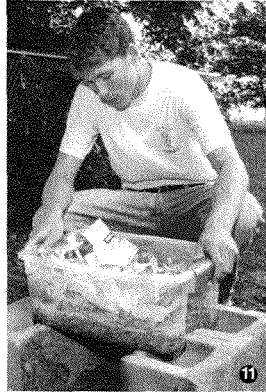

After about two months, you will see dark material that looks a lot like coffee grounds beginning to form at the bottom of the bin. These are the worm castings. Gently spoon the castings out into another container and add more bedding for your worms the next time you feed them. Use the castings to fertilize your garden.

## What Do Worms Eat?

You can feed vermipost worms any of the following: nongreasy leftovers, fruit and vegetable peels and scraps, bread, coffee grounds, tea bags, and ground eggshells.

*Do not* feed worms dairy products, meat, or bone products because worms have difficulty eating these and the items will decay slowly, attracting flies and rodents and creating foul odors.





# All About Bees

You may have never thought much about honey bees, but there has been a strong relationship between bees and humans for thousands of years. Without these winged creatures, many of our food sources would be in great peril. We rely on honey bees not only for the sweet honey they make, but more importantly for their ability to pollinate many of the crops and livestock feed our farmers grow.

## The Pollination Process

Some plants can produce seeds only if pollen is exchanged between flowers on the same plant, or from flowers of different plants from the same variety. Apple blossoms, for instance, need pollen from a different apple variety to set fruit; that can happen only when a honey bee or other pollinator visits blossoms from two different trees. Some plants, most grasses (corn, wheat, rice), some nut trees, and most conifers produce a lot of pollen, which is blown by the wind from one plant to another so seeds can be set.

Birds, bats, bumblebees, butterflies, and many other creatures help transfer pollen as they flit from flower to flower or feed on the nectar of several flowers. Honey bees, however, have three advantages over all of these other pollinators.

First, they practice what biologists call flower fidelity. That is, on a foraging trip they visit only one kind of flower so that when they transfer pollen it is to a flower that can use it. For example, a pollinator might fly from dandelion to clover to apple blossom, but that effort would be useless to all three plants. Honey bees pollinate with a purpose.

The second advantage is simply numbers. A full-size colony—whether living in a human engineered colony or a hollow tree—produces thousands of pollinating individuals during the growing season. This gives them the efficiency of numbers other pollinating insects do not have.

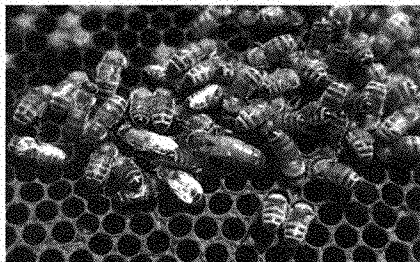

Her long, large abdomen makes the queen's wings appear shorter than her nest mates and makes her stand out among the workers. But indeed, her wings are the same size as theirs, and she can fly as well as they can.

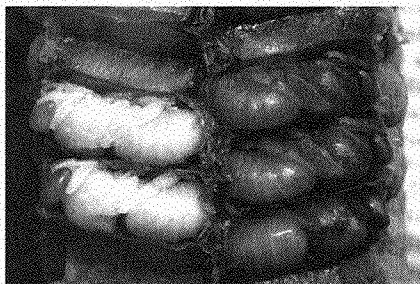

The pupae of honey bee drones to the right are more developed than those on the left.



The third reason is that honey bees can be raised in hives made by humans. These hives can be moved to a crop when it is blooming. The hives can also be relocated to make honey elsewhere or to pollinate yet another crop.

The full-size honey bee colony is made up of three castes, or social groups: a queen, a few hundred drones, and thousands of worker bees. There are also the developing young. The **queen** is basically an egg laying machine. She can lay 1,500 to 2,000 eggs a day in the summer. **Drones** are short-lived nonworker males that mate with queens from other colonies. **Workers** are infertile female honey bees that literally do all of the work, including protecting the colony and all of the foraging for food; in the process they pollinate all those seeds. **Eggs, larvae, and pupae** are the developing bees.

As far as humans are concerned, pollination is the honey bee's most important job; it is a fairly simple process. Foraging worker bees go from the flower of one plant to that of another of the same species seeking food. This food is nectar, a sugar-rich liquid that plants produce to attract honey bees and other pollinators. As a forager sucks in nectar from the base of the flower, she collects pollen from its anthers on the hairs of her body.

Some of this pollen brushes onto the sticky stigma of the next flower. That is how pollen is transferred from flower to flower. This leads to fertilization and the production of a new seed, enabling the pollinated plant to produce seed from which a new plant may grow. These

seeds may later be wrapped in the flesh of a delicious fruit or vegetable possible only because of the pollination services of our friend the honey bee.

Imagine now how different our world and eating habits would be if we had no honey bees to pollinate. Our supply of fresh fruits and vegetables would be greatly compromised. Many of the vegetables and fruits in the garden you are planning for this merit badge probably would not exist. Farmers would worry about the availability of many of the feeds for their animals. Cows, horses, chickens, and pigs all eat honey bee-pollinated feeds.

Pollination by honey bees is vital to humankind. We must be aware of the problems facing our honey bee population and work to help prevent these problems. Some of the challenges affecting honey bee populations worldwide may involve parasites such as mites, exposure to pesticides and other chemicals, malnutrition, stress, and loss of forage. According to scientists, multiple factors may lead to what is called *colony collapse disorder*, or certainly honey bee population decline.

## Colony Collapse Disorder

Many scientists believe a number of factors can contribute to a colony's demise and lead to what is called *colony collapse disorder*. Among them, exposure to pesticides and other chemicals, stress, disease, malnutrition, attack from pests such as mites, and the destruction of food sources all can negatively affect a colony. Scientists say there is no one reason.

## How Honey Is Made

Honey bee workers begin their tasks the day they emerge—fully developed—from their cell. They start by feeding young larvae, cleaning recently emptied honey comb cells, caring for the queen, and guarding the colony from robbers and other predators such as skunks, bears, and—in their opinion—beekeepers. The last task she undertakes as she ages is as a forager, gathering and storing nectar and pollen for food for the colony.

When a bee enters a flower, she sucks in the nectar and carries it in her honey stomach. During her trip she adds some saliva that contains the enzyme *invertase* to help convert nectar to honey. Back at the hive, she gives the nectar to another worker bee and the evaporation process begins. The bees evaporate the sugary nectar to a thick and sweet product that helps keep the honey from spoiling. It is then placed in the beeswax cells of the honey comb. A thin layer of new beeswax helps protect the cell.

---

Sweet! It takes some 20,000 bees to collect one pound of nectar, which converts to a little less than a quarter pound of honey.

---

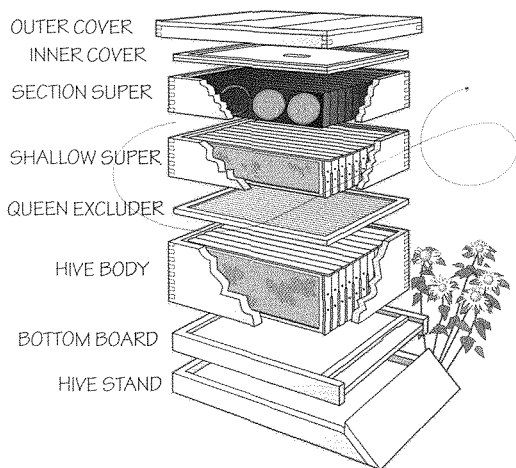

**The human-constructed beehive must have movable frames to be legal.**

## The Hive

In the wild, bees make honey and may store it in a cavity in a hollow tree, your attic, or anywhere else safe and out of the elements. To manage bees efficiently, beekeepers use a structure made by humans—a multipart “hive.” It serves as a safe home for bees and as a practical and manageable collection station for the beekeeper.

### Parts of a Modern Beehive

This hive has many parts, each one with a specific purpose and function. At the bottom, there is a hive stand with an alighting board. Although not essential, it keeps the hive off wet ground. Resting on the stand is the

bottom board or floor of your hive. Bees enter through the opening between this board and the hive body above it.

## Optional Requirement 8e

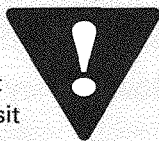

If you want to choose optional requirement 8e, first find out whether you are allergic to bee stings. To determine this, visit an allergist or your family physician. If you are allergic to bee stings, you should choose another option.

In completing requirement 8e, your counselor can help you find an established beekeeper. Ask if the beekeeper can meet with you and a buddy, if you can help prepare the supers for use in the beekeeper’s hive, then return later to help collect the honey and prepare it for market. Before your visit, be sure your buddy also has been checked by a physician and is not allergic to bee stings.

For help with locating a beekeeper in your state, visit [www.beeculture.com](http://www.beeculture.com) and click on “Resources,” then select “Find Help” and “Find a Local Beekeeper.”

Mounted on the bottom board is an entrance-contracting cleat that makes the entrance smaller. This helps keep out cold air and makes the entrance easier to defend from robbers. The cleat, which can be removed in hot weather, helps weak colonies guard the entrance and prevent robbing by stronger colonies. If robbing has already started, a beekeeper might put a bunch of loose grass over the hive entrance to discourage robbers from entering, or reduce the entrance so that only one bee at a time can enter.

**Any bee can be a criminal or robber. Robbers will generally overpower the guards of a weaker colony and carry the food supply back to their own hive. A beekeeper who sees bees flying around the hive corners or entrances with a quick, sneaky motion should suspect robbing. To help prevent robbing, beekeepers keep the hive cover bee-tight, don't leave frames exposed when honey is scarce, and don't leave a hive open long.**

Sitting on top of the bottom board is the *brood chamber* box or boxes. Often called a deep super, it can be one large box or two medium-size boxes. These boxes are used by the bees and managed by the beekeeper to provide an area where young bees can be raised. Some honey and lots of pollen also are stored there and used to feed the developing young bees.

Each rectangular frame provides support and surrounds comb *foundation* made of pure beeswax. Foundation is a sheet of beeswax or plastic embossed with the typical six-sided cell outline. This gives the bees a head start on where to build their beeswax honey comb and store honey and pollen.

Between the boxes where brood are raised and the boxes above this area, some beekeepers use a queen *excluder* to make colony management easier. This device is made of a wire grid with spaces in between that are large enough for workers to pass through but too small for queens and drones. When placed between the hive body and the honey supers, the queen cannot enter the honey storage area to lay eggs.

Every hive has a warehouse, where bees store honey not needed to feed their young or for everyday feeding but to save for winter months. This warehouse is simply a deep or medium-size—or even smaller—box called a *shallow*, or a special box used for producing comb honey.

---

**Beekeepers**  
use supers with  
regular movable  
combs to produce  
extracted (liquid)  
honey, and with  
round section  
honey supers  
to produce  
comb honey.

---

Propolis is the sticky, gummy substance bees gather from plants. Bees use it to fill small spaces where bacteria and fungi could hide, smooth rough spots, and reduce areas needing protection, such as an entrance that is too large.

Many beekeepers use an inner cover to help insulate bees from heat and cold and an outer cover over the top super for protection. The main feature of the movable frame hive is space where bees walk around inside the hive. These are spaces one-quarter to about three-eighths of an inch between each frame and the sides of the hive body.

If you leave a space larger than bee space—say you forget to replace a broken frame—the bees will fill it with honey comb, leaving just enough space for walking between the new comb and nearby frames. If you squeeze frames so close together the bees can't walk through, they will fill that space with *propolis* to keep pests and predators out.

## Tools and Clothing

You can control bees using a little smoke from a bee smoker. Smoke has a quieting effect on bees, which is why the smoker is one of the beekeeper's most useful tools. This cylindrical container holds smoldering fuel that produces the smoke. Squeezing a bellows attached to the cylinder forces air from the bellows through a small opening at the bottom of the cylinder and up through the smoldering fuel, and pushes the smoke out the spout.

Pine needles, rotten wood, corncobs, cotton waste, and scraps of burlap from untreated burlap bags are used as fuel. Point the spout just above the hive so that the bees nearest the smoker don't get too much smoke as you squeeze the bellows. Do not over-smoke the hive. Too much smoke will cause the bees to become immune to its effects and it will not offer any protection. Err on the side of too little rather than too much smoke, and stay safe.

When working with bees, wear smooth, light-colored clothes and long sleeves.





A bee suit—a zippered coverall fastened at the wrists and ankles with loop and hook bands—is safe and easy to use. Wear high-topped shoes or boots and good leather gloves. Always wear a veil, preferably one with a stiff screen made of wire or plastic so it stands out from your face. Fasten it securely around the neck. You should never be without a veil when working with bees.

Most important is that you feel safe with your gear. A good, complete outfit will essentially eliminate all opportunities for any errant bees to sting.



Be sure to join a local beekeeping club, read several good books, and find an experienced beekeeper to work with, for free, for the experience. If your merit badge counselor is not a beekeeper, your counselor can help you find one.

### Let the Honey Flow Begin

Before the honey begins to flow, beekeepers should be prepared by making sure their colonies are completely free of disease and full—but not too full—of bees. The queens should have their hives full of brood, but with enough room for egg laying.

If you suspect trouble in a colony, first check with your mentor or an experienced local beekeeper if possible for the most timely response. Otherwise, call your state or county bee (apiary) inspector and schedule a visit with someone from the county extension office as soon as possible. See the resources section at the end of this pamphlet for more information.

Adding more boxes may help, but at some point there are more bees than the queen can control, and the bees will swarm. What happens next? Basically, about half the bees and the old queen decide that the weather, available food outside, and their good health will allow them to leave the hive and begin a new hive, thus reproducing the colony. This is how honey bee colonies increase their numbers. Beekeepers try to avoid this by removing some of the bees and starting another colony before the bees do, thus gaining another colony for themselves and saving both colonies to make honey.

As a rule of thumb, flowers begin blooming in early spring in southern states—as early as February in the far South. Maples and willows bloom first, followed by the rest of the plants. As the weather warms, blooming moves farther north.

Southern beekeepers need to be ready for the honey flow very early; beekeepers in the far North must wait until April or even July for some crops. It pays to know when the local honey crops bloom. An experienced beekeeper can be very helpful sharing this information.

### Equipment

A beekeeper needs honey supers. These are above the brood nest, perhaps above a queen excluder (see the illustrated beehive earlier in this chapter). They serve as the hive's warehouse removable combs in which honey is stored.

Supers are added as bees begin to show evidence of needing more storage space.

Beekeepers reuse their honey supers. After extracting the honey, they place the honey supers back on the hives they were harvested from so the bees can clean them up and use the small amount of honey left there.

### Putting on Supers

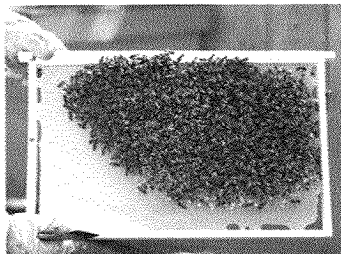

Exactly when to put on that first super will depend upon your location. In general, add a super just before the honey flow begins. Working with local beekeepers (attend a local association meeting) and good records will tell when productive local honey plants begin to bloom in your area. *Use this guide:* If the combs have fresh white wax along the top bars, the honey flow has already begun and you are a bit late.

Honey bees need extra room early to store and cure nectar before it becomes honey. If none is available, they will try and make some by building that white comb on the top bars—or they may simply quit collecting nectar; this is honey missed.

Usually, a beekeeper puts on only one super at a time. If a few combs are partly filled with honey or nectar, you might put them in the center of the first super, especially if it is full of foundation and not honey comb. This will “bait” the bees to come to that super and build new comb storage cells and, as beekeepers say, “draw them out.”

Don't be tempted to add too many supers too fast. The bees won't be able to guard them, and small hive beetles and wax moths will gain a foothold. This is where beekeeping becomes more of an “art” than a science, and experience is a good teacher. Once the honey flow slows up, stop adding supers. Let the bees fill existing supers. Remove honey as fast as it becomes ripe.

A super is usually ready to be removed for extracting when at least 75 percent and preferably 100 percent of the honey-filled cells are *capped over*. First remove supers that are not quite full and replace them directly above the queen excluder. Above the partially filled supers, place those that are completely capped and ready to harvest.

There are several ways to separate bees from frames in the filled supers, although it is probably best to have a local beekeeper show you which method to use. You can:

- Brush them off in front of the hive so they go right back in.
- Use a bee escape board, a board with a one-way entrance so that bees above the board in the capped honey frame can go below to keep warm at night but not return the next day.
- Use a fume board, a device that puts a smell into the super that bees don't like (but you will) so they leave.
- Use a bee blower if you have lots of bees. This works much like a leaf blower, dislodging the bees from the super once it's removed, then they can fly back to the hive.

---

*Capped over*  
means that the  
honey is sealed  
into the cell  
with wax.

---

---

Beekeepers harvest beeswax by collecting and then melting old or broken combs and the beeswax covers, called cappings. The cappings cover and protect the honey when it is in the hive and are removed during honey extraction. Once harvested, cappings are melted, filtered, and cleaned, ready to be used for a variety of purposes.

---

## Extracting Honey

Once harvested, the honey-filled supers must be protected from robbers. The sooner you extract the honey the better. If you can't extract it immediately, completely cover both the bottom and top of the pile of supers and all holes and cracks temporarily with duct tape. Before you begin, place the supers in a warm room if possible. Warm honey flows faster and strains easier than cold honey, and soft, warm cappings wax is easier to remove than wax that is cold and hard.

Extractors come in two styles. The tangential extractor usually holds a small number of frames and requires more work but is more affordable. The radial extractor is more expensive than a tangential, but it makes the extracting process easier. An experienced beekeeper can show you how to use an extractor.

When you are ready, set up the extracting area with the warmed supers, uncapping tank, and your uncapping tools nearby. Some beekeepers use electrically heated knives, some use sharp uncapping knives heated in hot water, and others use large machines that do this task automatically. Keep the extractor close to the uncapping tank so uncapped frames can immediately go into the extractor. If you are using a small extractor, you will be uncapping faster than you are extracting. Have a clean tub of some sort to store uncapped, honey-dripping frames in until you can extract them.

Be sure the extractor is well lubricated and the gate at the bottom isn't stuck shut. Anchor it to the floor or something solid to help keep it from moving around. Put the strainer in place on top of the empty pail. Keep it and multiple pails clean and ready to use. Finally, have empty supers ready for when you remove frames from the extractor. These will be sticky and dripping honey, so protect the floor below the supers where they will be returned.

Use a hive tool to loosen frames in the first super you will uncap so they are easy to grasp and remove. Place the first frame on the crossbar that rests on top of the uncapping tank. The bar often has a nail sticking out where you can rest the frame, making it easy to turn since you uncap both sides before placing it in the extractor.

Begin cutting the wax capping from the top or bottom of the frame, tipped so that the wax capping falls off the frame into the tub below. Some begin at the bottom, some at the top. Experiment and find the way that works best for you and makes the least mess. After enough combs are uncapped, load the extractor.

Extracted, liquid honey, strained and clean, is now ready to be bottled and given to friends or sold. Use clean jars with a tight lid and a label identifying the beekeeper. Make sure the bottles are not sticky when ready to sell or give away.

Your uncapping should allow the honey trapped in the wax to drip below so after a day or so most of the honey has drained. Empty and strain the honey. Place the cappings in a pail half full of water and wash off the remaining honey. Freeze them for a short period of time to kill the wax moth, or melt it down in a solar wax melter to a usable form.

### Processing Comb Honey

Extractors are not needed to produce comb honey. The round-section super is removed from the hive and the individual round sections gently removed from the frames. Harvest sections when completely filled with honey and completely capped, with no holes or damage. Place the plastic caps that came with the equipment on each side. You can cut incomplete sections for cut comb honey, return them to the bees if the honey is still flowing, crush and strain them for the liquid honey, or save them and feed them back to the bees later, for winter feed.

The completed sections should be placed in airtight plastic bags and immediately frozen for a few days to kill wax moth eggs. If allowed to hatch, the larvae will burrow through the delicate comb and ruin it.

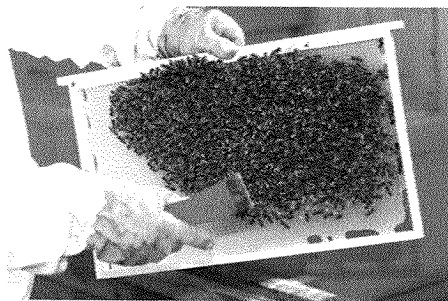

---

The wax from cappings, the finest you can harvest, is prized by anyone making lotions, creams, or candles.

---

Honey bees produce beeswax, which is useful in making candles, cosmetics, salves, ointments, polishes, and many other products. It is also used to make candy coating.

## A Dozen Tips for Establishing Your First Hive of Bees

These helpful tips for new beekeepers come from Kim Flottum, author of *The Backyard Beekeeper* and editor of *Bee Culture* magazine. (See the resources section.)

1. Have the hive in its location and the hive stand and all equipment ready *before* you pick up your bees. Assemble and paint all the woodenware, and insert the foundation into the frames. Pick a good place to keep the bees, out of the way in the yard and safe from animals and curious neighbors. Put a screen in front of the hive, about 4 or 5 feet away, so when the bees leave they fly up and out of the way in the yard.
2. When you pick up your package, make sure it is OK, with only a few dead bees on the bottom and no leaks in the screened sides. Transport it safely, especially if it is hot outside. Bees can perish in just a few minutes left in the trunk of your car. Some dealers sell a net with a drawstring to transport your package to and from the car. Keep the air conditioning running.

As soon as you get home, put the package in a cool, dark place (like a garage or basement) until you are ready to install the bees. Spray the screened sides with a 1:1 sugar mist to settle and feed the hungry bees; don't rely on the feed provided in the package. The syrup will keep them busy while you prepare.

3. Get your hive ready. Remove half the frames from the middle of the box. Have a hive tool, screwdriver, pliers, rubber bands, a piece of cardboard or plywood large enough to cover the feeder can hole if no cover is provided, and a sugar spray bottle ready. **Put on your full protective gear.** Have a feeding can or top feeder ready and full, and an extra super ready to cover the feeder can if you use one.
4. When the box is ready, within a foot or two on one side of the hive, gently thump the package on the ground so the bees inside fall to the bottom of the package, away from the queen cage and feeder can. Pry off the cover on the top of the package if there is one, but keep it close. Using your hive tool or a screwdriver, carefully remove the can inside containing food, shake the bees off in front of the hive, and quickly cover the hole in the package.
5. This sometimes happens, but *don't drop the queen cage*—which is suspended right next to the can—into the bees below. If you replace the cover so the bees don't leave, gently roll the bees in the cage until you can locate the queen cage. Carefully remove the cage and put in your pocket to keep her warm. As soon as you have her, cover the hole. There will be some bees in the air, but they are confused and shouldn't be a problem. Don't worry; this is why you have your veil on.
6. If the queen cage is still in the slot or hole, remove it now and place the cage in a pocket to keep her warm.

7. Spray the bees with the sugar syrup, then thump the cage to settle them to the bottom of the cage.
8. Carefully dump the bees into the cavity produced when the frames were removed. Bees will definitely be in the air now, but they are looking for their nest mates and don't care much about you. They are not defending a nest yet and have little inclination to sting.
9. Let the bees in the box spread out on the bottom and begin to move onto the frames. Place the screened package cage in front of the hive's opening so stragglers can make their way into the hive. Slowly replace the frames, not squishing the bees. When you are ready to put in the last frame, remove the queen cage from your pocket.

Using the tin strip or holder, suspend the cage between the last two frames not quite in the middle of the box. If there is nothing around to hang the cage, take the last frame and place the queen cage horizontally on the face of the foundation with the screened side out. Put two or three rubber bands around the frame to hold her cage in place and return the last frame to the box.

**Do not** remove either of the corks covering the openings in the ends of the queen's cage. The bees will start to surround the queen to keep her warm and feed her. Put the feeder on top of the frames but not over the queen. Put another box over the feeder, then the cover to protect it all.

You are done for now. Gather your tools, then watch for a bit as the bees find the door and begin to search for food. A good experiment is to see how long it is before they begin to fly.

10. Return in four or five days. Check if you need to refill the feeder. Bees will eat a lot of sugar syrup, and you must not let them go hungry, even if they are flying and bringing in nectar and pollen. Three days of rain and they can starve to death, so make sure they have more than enough food, all the time.

Using a tiny bit of smoke, move the bees away from the frame with the queen cage still fastened to it. Remove the frame, remove the queen cage, and now remove the cork on the candy end of the cage and replace as before.

11. In a week, check again. The queen should be released from the cage and laying eggs. If not, remove the cork on the other end and replace the cage as before, and she will walk right out, ready to go to work. The worker bees should be flying, bringing home pollen and nectar. If you started with foundation, there should be two or three combs, with new comb being built so the bees have a place to store food and raise their young. Congratulations! You are now a beekeeper.
12. Check the hive again in a couple of weeks to make sure the queen is working, comb is being built, that some of the brood (white grub-like larvae) are large enough to see in the cells, and that honey is being made. Make sure there is food in the feeder and pollen is coming in.

# Gardening Resources

## Scouting Literature

*Architecture and Landscape Architecture, Bird Study, Insect Study, Nature, Plant Science, and Soil and Water Conservation* merit badge pamphlets

With your parent's permission, visit the Boy Scouts of America's official retail website, [www.scoutshop.org](http://www.scoutshop.org), for a complete listing of all merit badge pamphlets and other helpful Scouting materials and supplies.

## Books

- Bartholomew, Mel. *All New Square Foot Gardening*, 3rd ed. Cool Springs Press, 2018.
- Bradley, Fern Marshall, Barbara W. Ellis, and Ellen Phillips, eds. *Rodale's Ultimate Encyclopedia of Organic Gardening*. Rodale Press, 2017.
- Bush, Michael. *The Practical Beekeeper: Beekeeping Naturally*, volumes I, II, and III. X-Star Publishing Company, 2011.
- Cranshaw, Whitney, and David Shetlar. *Garden Insects of North America: The Ultimate Guide to Backyard Bugs*, 2nd ed. Princeton University Press, 2018.
- Elzer-Peters, Katie. *Beginner's Illustrated Guide to Gardening: Techniques to Help You Get Started*. Cool Springs Press, 2012.
- Flottum, Kim. *The Backyard Beekeeper: An Absolute Beginner's Guide to Keeping Bees in Your Yard and Garden*, 4th ed. Quarry Books, 2018.
- Gillman, Jeff. *The Truth About Garden Remedies: What Works, What Doesn't, and Why*. Timber Press, 2008.
- McGee, Rose Marie Nichols, and Maggie Stuckey. *The Bountiful Container*. Workman Publishing Company, 2002.
- Phillips, Ellen, and C. Colston Burrell. *Rodale's Illustrated Encyclopedia of Perennials*. Rodale Press, 2004.
- Pleasant, Barbara. *Starter Vegetable Gardens: 24 No-Fail Plans for Small Organic Gardens*. Storey Publishing, 2010.
- Pleasant, Barbara, and Deborah L. Martin. *The Complete Compost Gardening Guide*. Storey Publishing, 2008.
- Richardson, Fern. *Small-Space Container Gardens: Transform Your Balcony, Porch, or Patio With Fruits, Flowers, Foliage, and Herbs*. Timber Press, 2012.
- Sanchez, Janet, and the editors of Sunset Books. *Perennials*, 2nd ed. Sunset Books, 2000.

## Periodicals

### Bee Culture

Toll-free telephone: 800-289-7668  
Website: [www.beeculture.com](http://www.beeculture.com)

### Garden Gate

Toll-free telephone: 800-341-4769  
Website:  
[www.gardengatemagazine.com](http://www.gardengatemagazine.com)



**Mother Earth News**

Toll-free telephone: 800-234-3368

Website:

www.motherearthnews.com

**Organizations and Websites****American Horticultural Society**

Website: www.ahsgardening.org

**Back Yard Beekeepers Association**

Website:

www.backyardbeekeepers.com

**Bee Research Laboratory**

USDA Agricultural Research Service

Telephone: 301-504-7299

Website:

www.ars.usda.gov/northeast-area/beltsville-md-barc/beltsville-agricultural-research-center/bee-research-laboratory/

**Home and Garden Television**

Website: www.hgtvgardens.com

**National Gardening Association**

Website: www.garden.org

**National Wildlife Federation**

Toll-free telephone: 800-822-9919

Website: www.nwf.org

**Old Farmer's Almanac**

Telephone: 603-563-8111

Website: www.almanac.com

**Trust for Public Land**

Toll-free telephone: 800-714-5263

Website: www.tpl.org

**U.S. Department of Agriculture**

1400 Independence Ave. SW

Washington, DC 20250

Telephone: 202-720-2791

Website: www.usda.gov

**U.S. National Arboretum**

3501 New York Ave. NE

Washington, DC 20002-1958

Telephone: 202-245-4523

Website: www.usna.usda.gov

**World Aquaculture Society**

Telephone: 225-347-5408

Website: www.was.org

**Acknowledgments**

The Boy Scouts of America thanks Randy Lynn, D.V.M., for lending his subject expertise, time, and assistance with the bee-related information in this merit badge pamphlet.

We are grateful to Kim Flottum, editor, *Bee Culture* magazine and author of *The Backyard Beekeeper*, for providing his subject expertise and time.

The Boy Scouts of America is grateful to the men and women serving on the National Merit Badge Subcommittee for the improvements made in updating this pamphlet.

**Photo and Illustration Credits**

Scott Bauer, USDA Agricultural Research Service, Bugwood.org, courtesy—page 60 (*plant roots*)

David Cappaert, Michigan State University, Bugwood.org, courtesy—page 65 (*butterfly*)

Carl Dennis, Auburn University, Bugwood.org, courtesy—page 82 (*queen bee*)

Susan Ellis, Bugwood.org, courtesy—page 64 (*assassin bug*)

Barry Rice, sarracenia.com, Bugwood.org, courtesy—page 51 (*periwinkle*)

Shutterstock.com—cover (*toad*, ©ivosar; *honey bee on flower*, ©kesipun; *starter plant*, ©Anna Hoychuk; *caterpillar*, ©Voyagerix; *garden*, ©Irina Fischer); pages 6 (©Innershadows Photography), 7 (©Terrie L. Zeller), 11 (©Kzenon), 18 (©Jenn Huls), 19 (©Igor Stramyk), 20 (©Zocchi), 22 (©Heike Rau), 23 (©ningii), 24 (©Ingrid Balabanova), 27 (©DanielW), 35 (©Webitect), 38 (*parsley*, ©Yaroslava), 40 (©NitroCephal), 41 (*water bottle*, ©Danny Smythe), 42 (©tobkatrina), 43 (©CGN089), 45 (©Ralu Cohn), 46 (*apple*, ©Sergey Peterman), 48 (©Elena Elisseeva), 50 (*arbor*, ©V.J. Matthew), 57 (©ehtesham), 64 (*ladybug*, ©Galushko Sergey), 69 (*snail*, ©sbellott), 71 (©sisqopote), 72 (*compost bin*, ©BMJ), 75 (*butterfly*, ©chanwangrong), 76 (*ladybug*, ©Marya Kutuzovak; *birdhouse*, ©Edward Fielding), 77 (*worms*, ©Danie Nel), 79 (*worm food*, ©christopher kolaczan), 80 (©Jovan Barajevac), 82 (*pollinating bee*, ©Andre Goncalves), 86 (©maggee), 87 (*working beekeeper*, ©danyimages; *girl in bee suit*, ©Nidvoray), 88 (©rtbilder), and 91 (©rtbilder)

Forest and Kim Starr, U.S. Geological Survey, Bugwood.org, courtesy—page 60 (*caterpillar*)

U.S. Department of Agriculture, courtesy—pages 10 (*hardiness zones*) and 46 (*ChooseMyPlate*)

USDA Agricultural Resource Service/Keith Weller, courtesy—page 63 (*nematodes*)

Wikipedia.org/HitroMilanese/courtesy—page 51 (*dahlia*)

Wikipedia.org/Waughsberg—page 82 (*pupae*)

All other photos and illustrations not mentioned above are the property of or are protected by the Boy Scouts of America.

Daniel Giles—pages 8, 9, 36, 47, 49 (*coniferous and evergreen images*), 50 (*deciduous images*), 51 (*petunias*), 56, 59, 61 (*chewed leaf, bug droppings, diseased fruit, tomato*), 63 (*grubs*), 65 (*toad*), 66 (*marigolds, Queen Anne's lace, daisies*), 68, 69 (*young gardener*), 70, 72 (*label*), and 77–79 (*all images of Scout assembling a vermipost bin*)

John McDearmon—all illustrations on pages 39, 73–75, and 84

Brian Payne—page 58

## MERIT BADGE LIBRARY

Though intended as an aid to youth in Scouts BSA, and qualified Venturers and Sea Scouts in meeting merit badge requirements, these pamphlets are of general interest and are made available by many schools and public libraries. The latest revision date of each pamphlet might not correspond with the copyright date shown below, because this list is corrected only once a year, in January. Any number of merit badge pamphlets may be revised throughout the year; others are simply reprinted until a revision becomes necessary.

If a Scout has already started working on a merit badge when a new edition for that pamphlet is introduced, *they may continue to use the same merit badge pamphlet to earn the badge and fulfill the requirements therein.* In other words, the Scout need not start over again with the new pamphlet and possibly revised requirements.

Merit Badge Pamphlet	Year	Merit Badge Pamphlet	Year	Merit Badge Pamphlet	Year
American Business	2019	Family Life	2016	Plant Science	2018
American Cultures	2013	Farm Mechanics	2017	Plumbing	2012
American Heritage	2013	Fingerprinting	2014	Pottery	2008
American Labor	2018	Fire Safety	2019	Programming	2019
Animal Science	2014	First Aid	2019	Public Health	2017
Animation	2015	Fish and Wildlife		Public Speaking	2013
Archaeology	2017	Management	2014	Pulp and Paper	2019
Archery	2019	Fishing	2013	Radio	2017
Architecture and Landscape Architecture	2014	Fly-Fishing	2014	Railroading	2019
Art	2013	Forestry	2019	Reading	2013
Astronomy	2019	Game Design	2019	Reptile and Amphibian Study	2018
Athletics	2019	Gardening	2013	Rifle Shooting	2012
Automotive Maintenance	2017	Genealogy	2013	Robotics	2016
Aviation	2014	Geocaching	2019	Robotics	2016
Backpacking	2016	Geology	2016	Rowing	2019
Basketry	2017	Golf	2019	Safety	2016
Bird Study	2019	Graphic Arts	2013	Salesmanship	2013
Bugling (see Music)		Hiking	2016	Scholarship	2014
Camping	2019	Home Repairs	2012	Scouting Heritage	2019
Canoeing	2019	Horsemanship	2013	Scuba Diving	2009
Chemistry	2018	Indian Lore	2006	Sculpture	2019
Chess	2016	Insect Study	2019	Search and Rescue	2018
Citizenship in the Community	2015	Inventing	2016	Shotgun Shooting	2013
Citizenship in the Nation	2019	Journalism	2019	Signs, Signals, and Codes	2015
Citizenship in the World	2015	Kayaking	2019	Skating	2015
Climbing	2019	Landscape Architecture (see Architecture)		Small-Boat Sailing	2019
Coin Collecting	2017	Law	2019	Snow Sports	2019
Collections	2013	Leatherwork	2017	Soil and Water Conservation	2019
Communication	2013	Lifesaving	2019	Space Exploration	2016
Composite Materials	2012	Mammal Study	2014	Sports	2012
Cooking	2014	Medicine	2012	Stamp Collecting	2013
Crime Prevention	2012	Metalwork	2012	Surveying	2004
Cycling	2017	Mining in Society	2014	Sustainability	2013
Dentistry	2016	Model Design and Building	2010	Swimming	2019
Digital Technology	2014	Motorboating	2019	Textile	2014
Disabilities Awareness	2016	Moviemaking	2013	Theater	2019
Dog Care	2016	Music and Bugling	2013	Traffic Safety	2016
Drafting	2013	Nature	2014	Truck Transportation	2013
Electricity	2013	Nuclear Science	2019	Veterinary Medicine	2015
Electronics	2014	Oceanography	2012	Water Sports	2019
Emergency Preparedness	2019	Orienteering	2016	Weather	2019
Energy	2014	Painting	2016	Welding	2016
Engineering	2016	Personal Fitness	2019	Whitewater	2019
Entrepreneurship	2013	Personal Management	2019	Wilderness Survival	2019
Environmental Science	2015	Pets	2013	Wood Carving	2016
Exploration	2016	Photography	2016	Woodwork	2019
		Pioneering	2019		

## BOY SCOUTS OF AMERICA • SUPPLY GROUP

### NATIONAL DISTRIBUTION CENTER

2109 Westinghouse Boulevard

P.O. Box 7143

Charlotte, NC 28241-7143

To place an order,  
call customer service  
toll-free 800-323-0736  
or go to  
[www.scoutshop.org](http://www.scoutshop.org)

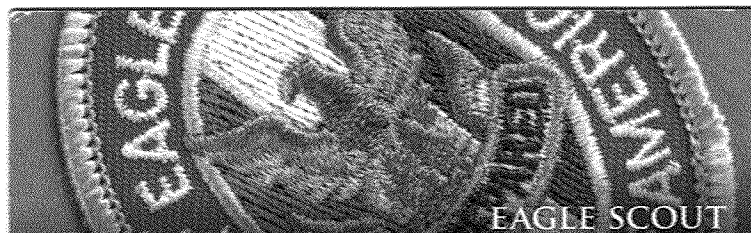

EAGLE SCOUT



THE SUMMIT

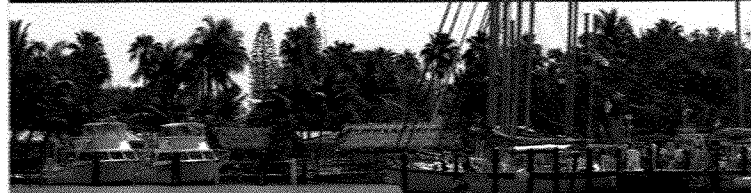

FLORIDA SEA BASE

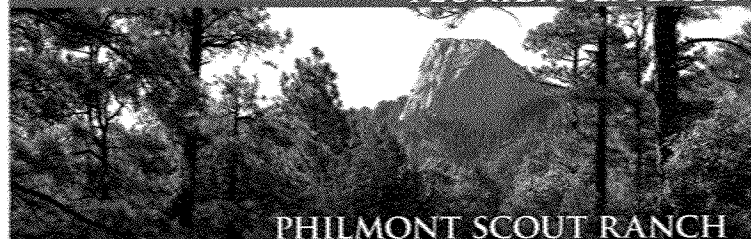

PHILMONT SCOUT RANCH

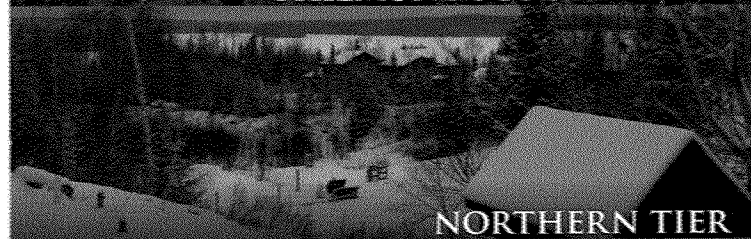

NORTHERN TIER

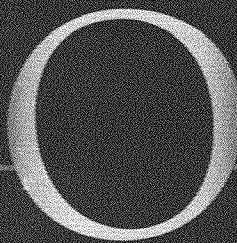

ON THE ROAD TO  
HIGH ADVENTURE

THE SUPPLY GROUP IS  
READY TO BE A PARTN  
ON YOUR TRAIL TO  
EAGLE THROUGH HIGH  
ADVENTURE. THE  
ADVENTURE IS YOURS  
AND WE ARE READY  
WITH THE GEAR YOU  
WILL NEED. YOU CAN  
DEPEND ON THE LATEST  
IN LIGHTWEIGHT,  
DURABLE, QUALITY  
GEAR THAT WILL  
MEET AND SURPASS  
YOUR TOUGHEST  
REQUIREMENTS.



WWW.SCOUTSHOP.ORG

SKU 654566



35902

2020 Print

