

MERIT BADGE SERIES

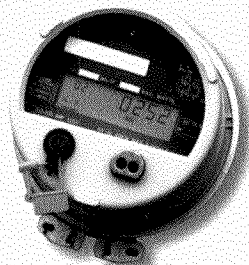

# ELECTRICITY



BOY SCOUTS OF AMERICA



STEM-Based



## How to Use This Pamphlet

The secret to successfully earning a merit badge is for you to use both the pamphlet and the suggestions of your counselor.

Your counselor can be as important to you as a coach is to an athlete. Use all of the resources your counselor can make available to you. This may be the best chance you will have to learn about this particular subject. Make it count.

If you or your counselor feels that any information in this pamphlet is incorrect, please let us know. Please state your source of information.

Merit badge pamphlets are reprinted annually and requirements updated regularly. Your suggestions for improvement are welcome.

## Who Pays for This Pamphlet?

This merit badge pamphlet is one in a series of more than 100 covering all kinds of hobby and career subjects. It is made available for you to buy as a service of the national and local councils, Boy Scouts of America. The costs of the development, writing, and editing of the merit badge pamphlets are paid for by the Boy Scouts of America in order to bring you the best book at a reasonable price.

Send comments along with a brief statement about yourself to  
Pilots and Program Development, S272

Boy Scouts of America • 1325 West Walnut Hill Lane • Irving, TX 75038  
If you prefer, you may send your comments to [merit.badge@Scouting.org](mailto:merit.badge@Scouting.org).

BOY SCOUTS OF AMERICA  
MERIT BADGE SERIES

# ELECTRICITY



*"Enhancing our youths' competitive edge through merit badges"*



BOY SCOUTS OF AMERICA®

# Requirements

1. Demonstrate that you know how to respond to electrical emergencies by doing the following:
  - a. Show how to rescue a person touching a live wire in the home.
  - b. Show how to render first aid to a person who is unconscious from electrical shock.
  - c. Show how to treat an electrical burn.
  - d. Explain what to do in an electrical storm.
  - e. Explain what to do in the event of an electrical fire.
2. Complete an electrical home safety inspection of your home, using the checklist found in this pamphlet or one approved by your counselor. Discuss what you find with your counselor.
3. Make a simple electromagnet and use it to show magnetic attraction and repulsion.
4. Explain the difference between direct current and alternating current.
5. Make a simple drawing to show how a battery and an electric bell work.
6. Explain why a fuse blows or a circuit breaker trips. Tell how to find a blown fuse or tripped circuit breaker in your home. Show how to safely reset the circuit breaker.
7. Explain what overloading an electric circuit means. Tell what you have done to make sure your home circuits are not overloaded.

8. Make a floor plan wiring diagram of the lights, switches, and outlets for a room in your home. Show which fuse or circuit breaker protects each one.
9. Do the following:
  - a. Read an electric meter and, using your family's electric bill, determine the energy cost from the meter readings.
  - b. Discuss with your counselor five ways in which your family can conserve energy.
10. Explain the following electrical terms: volt, ampere, watt, ohm, resistance, potential difference, rectifier, rheostat, conductor, ground, circuit, and short circuit.
11. Do any TWO of the following:
  - a. Connect a buzzer, bell, or light with a battery. Have a key or switch in the line.
  - b. Make and run a simple electric motor (not from a kit).
  - c. Build a simple rheostat. Show that it works.
  - d. Build a single-pole, double-throw switch. Show that it works.
  - e. Hook a model electric train layout to a house circuit. Tell how it works.



## Contents

What Is Electricity? . . . . .	6
Forms of Electricity . . . . .	9
Common Electrical Terms . . . . .	24
Current in Motion . . . . .	29
Responding to Electrical Emergencies . . . . .	53
Electricity Resources . . . . .	62

# What Is Electricity?

---

The word  
*electricity* comes  
from *electron*,  
the Greek word  
for amber.

---

Electricity is a powerful and fascinating force of nature. As early as 600 B.C., observers of the physical world suspected that electricity existed but did not have a name for it. In fact, real progress in unraveling the mystery of electricity has come only within the last 250 years. Important discoveries by scientists such as Benjamin Franklin, who proved that lightning is a tremendously powerful electrical spark, have given us a more complete picture of what electricity is and how we can harness its power.

To begin to understand electricity as an awesome force, one must start with the basics. Electricity is a rapid transfer of charged particles called electrons, which create levels of energy depending upon how they transfer.

## Atoms

All things are made of tiny particles called atoms. You are made of atoms, and so are your friends, your clothes, the food you eat, and the air you breathe. Atoms are so small that it takes millions of them to form the period at the end of this sentence.

Every atom is made up of even tinier particles called protons, neutrons, and electrons. Protons are positively charged, and neutrons are neutral—they have no charge. Together, protons and neutrons form the nucleus, or core, of an atom. Electrons, which are negatively charged, speed around the nucleus, orbiting it in layers called shells.

The positive charge of the protons in the nucleus equals the total negative charge of the electrons in orbit. This makes the atom neutral, or balanced. Protons and electrons have a natural attraction to each other, which helps to keep the atom stable. Much as the gravitational force of the sun holds planets in their orbits, electrical forces hold electrons around the nucleus.



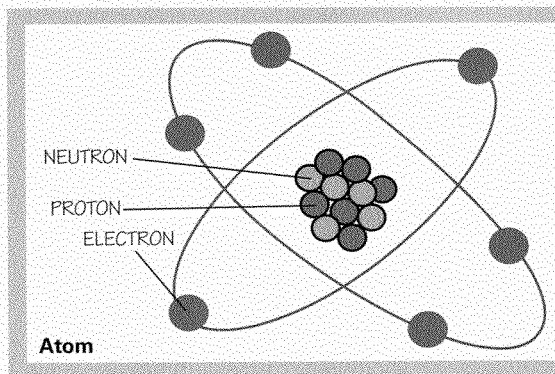

To picture the structure of an atom, think about the arrangement of our solar system. Just as planets orbit the sun, electrons move around the nucleus of an atom.

It is important to understand the atom's structure because the electrical charge of the electron is the basic unit of electricity. The position and movement of positively and negatively charged particles cause the electric and magnetic effects you will be working on to earn your Electricity merit badge.

## Ions and Balance

The bond that holds electrons in orbit is weakest in the atom's outermost shells. A free-moving electron can bump into and knock electrons out of an atom's outermost shell. These loose electrons, in turn, can bump into still other atoms and dislodge more electrons. Moving together, these freed electrons form electric current.

Electrons are easily dislodged from, or rubbed off of, an atom because they are lightweight and, in the outermost shells, accessible. (Protons are heavy and do not rub off easily.) Imagine electrons as grains of dust spinning swiftly around a central core of iron. You can see why the lightweight, negatively charged electrons are constantly rubbing off or being lifted by nearby atoms and ions.

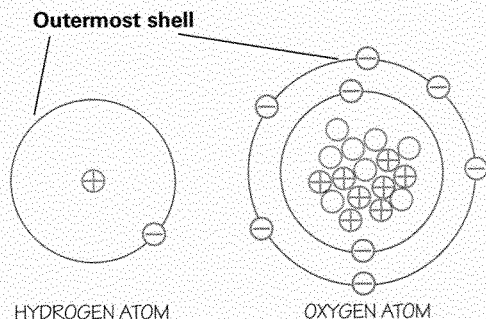

When an atom loses one or more of its electrons, the atom becomes positively charged, or out of balance. If an atom gains free-moving electrons, it becomes negatively charged, and also out of balance. Out-of-balance atoms are called ions.

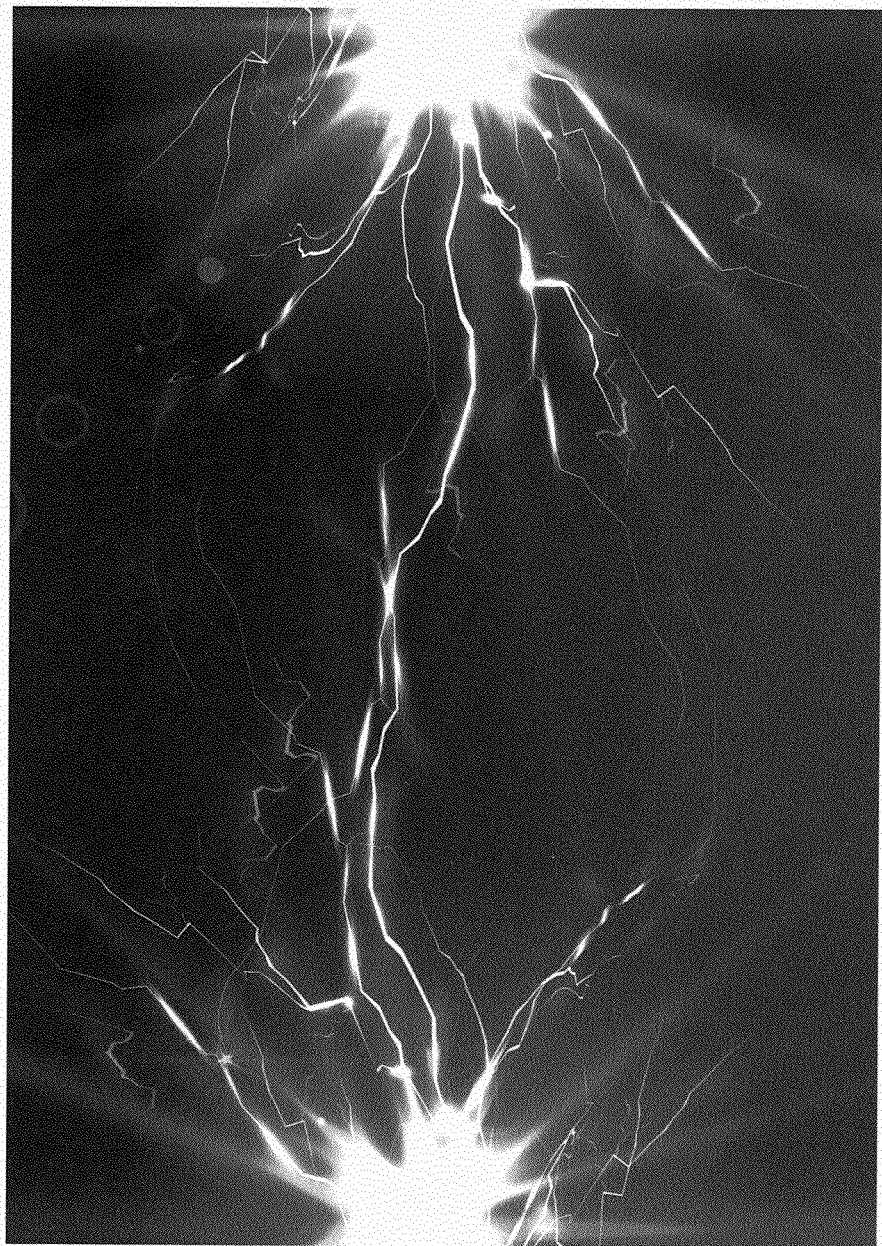

# Forms of Electricity

Have you ever watched with wonder as lightning lit up the night sky during a thunderstorm? Have you ever combed your hair on a cold day and heard it crackle? Have you ever pulled a clingy sock away from your T-shirt as it was removed from a warm dryer? All these phenomena are examples of electricity.

## Static Electricity

Try this experiment. Shuffle across a thick carpet on a dry day and then lightly touch a doorknob. You will jump. You might even see a spark. The crackling noises and sparks indicate the presence of static electricity.

Thales of Miletus (625–547 B.C.), an ancient Greek philosopher, knew rubbing amber, or fossilized tree resin, with a piece of wool or fur would make a small, lightweight object like a feather fly up and cling to it. Rubbing makes the amber electrically negative and able to exert force over a distance, like a magnet. As the charge is lost, the amber loses its attraction and the feather floats back down.

While Thales did not completely understand the force that attracted a feather to rubbed amber, he recorded some of the first observations of magnetism and electricity.

Static electricity is electricity transferred by rubbing objects together. It can be stored on the surface of materials like rubber, glass, cloth, and amber. The electrical charge builds up until it discharges, or jumps. The sparks and crackling noises are static electricity in motion.



When you comb your hair and produce static electricity, loose electrons are rubbing off the hair atoms and clinging to the atoms of the comb. Losing electrons leaves the hair atoms positively charged; gaining extra electrons makes the comb negatively charged. Because different (unlike) charges attract each other, your hair tries to stick to the comb.

**Unlike charges attract; like charges repel, similar to the way unlike poles of magnets attract while the like poles repel. Try this experiment: Rub two inflated balloons against your sweater and tie them to a stick with the rubbed sides facing each other. Because both balloons have the same charge they will swing away from, or repel, one another.**

Rubbing, or friction, does not create static electricity; it merely separates negative and positive charges and transfers them onto different bodies, or onto different parts of the same body.

**A static charge is an accumulated electrical charge on an object. It is capable of producing a spark that can cause an explosion. For example, when filling the gas tank of a car or boat, you must keep the pump nozzle in constant contact with the fill pipe to prevent a static charge (a spark) from igniting gas fumes.**

When objects out of electrical balance approach each other, a spark may jump from one to the other, which is what happened when you shuffled across the carpet and touched the doorknob. Electrons jumped from an object overcharged with electrons to an object short of electrons.

## Lightning

Lightning is caused by static electricity. As positive and negative charges become separated during a thunderstorm, they build up in different parts of the clouds. Eventually, they jump the gap between regions of opposite charge, discharging their buildup. The discharge is lightning—a mighty stream of electrons leaping through the sky. Some lightning bolts strike the ground, but most jump from one part of a cloud to another.

## Electrostatic Generators

Electrostatic generators, created in England by Francis Hauksbee (1666–1713), generated significant amounts of electrical charge. One such machine used the friction created from leather pressing on a revolving glass cylinder to produce an electrical charge, which in turn was transferred to a metal comb. The electrical charge then traveled from the comb to an attached metal ball, and then into a Leyden jar for storage.



## Ben Franklin's Kite

After watching lightning jump from cloud to cloud and from cloud to ground, American statesman and scientist Benjamin Franklin (1706–1790) determined that an electrical charge was like a fluid seeping through an object, and that it could jump to another object, making a spark. To prove his point, he tied a metal key to a kite and flew it in a sky threatening a thunderstorm. The electrical charge from lightning leapt to the key and produced a spark of electricity.

Franklin was lucky to survive the risky experiment, but he proved that lightning is a form of electricity. After his experiment, he invented the lightning rod, an iron rod that would safely conduct lightning from the top of a building to the ground.

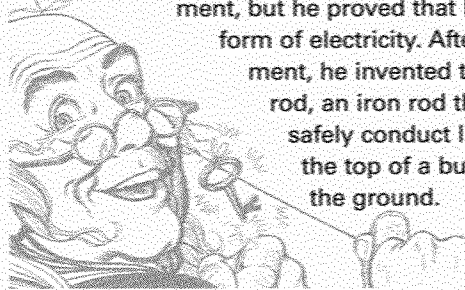

Ben Franklin's original lightning rod, above; modern-day lightning rod, below

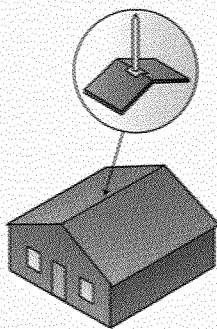

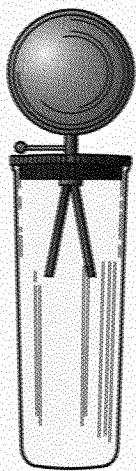

Named for the university in the Netherlands where it was invented, the Leyden jar was the first storage container for electricity. The charge could not pass through the glass so it built up inside. If a metal rod was held near the jar, the charge leapt from a metal ball on top through a discharger to the outer metal coating on the jar, causing a spark.

Modern devices that store electrical charge are called capacitors. They are found inside many household appliances, from washing machines to CD players. Though most are the size of a dime, they generally follow the same principle as a Leyden jar.

## Magnetism

Electricity and magnetism, although they seem quite different, are actually two forms of the same force. An electric *current* produces magnetism. To put it another way, whenever electricity moves, magnetism is produced. And whenever a magnetic force field changes, electricity is produced.

William Gilbert (1544–1603), a doctor to England's royal family, wrote about magnetism and electricity in 1600. He was the first person to use the word "electric," and he invented what is believed to be the earliest electrical instrument. The device had a pointer, which would swing toward objects like straw and paper that carried an electrical charge when rubbed. He named objects that attracted the pointer "electrics," and those that did not "nonelectrics."

Gilbert believed there were two types of electricity. Glass rubbed with silk made what he called vitreous electricity. Amber rubbed with fur made resinous electricity. Gilbert showed that objects with the same type of electricity repelled each other, while those containing different kinds attracted each other.

## Electromagnetism

Italian Alessandro Volta (1745–1827) thought electricity came only from contact between two metals; he called it metallic electricity. He was not absolutely correct, either. But Volta did invent the earliest electric cell, which became known as the voltaic pile. It used two different metals, separated by moist chemicals, to produce a continuous transfer of electrical charge. When the charge transferred along wires, the chemicals separated out more electrical charge. By piling up lots of cells, Volta created the first battery, with every set of cells producing slightly more than 1 volt of electricity.

**Volt**, the modern unit of electric potential, is the strength or electric pressure of the transferring charge. Today's high-voltage power lines operate at 500,000 volts or more while a modern house circuit operates at 110 or 220 volts.

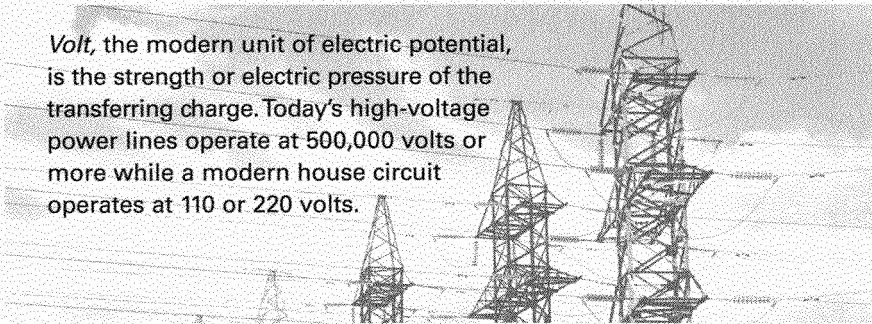

With Volta's invention of the battery in 1800, scientists finally had a source of steady electric current that could be transferred. Twenty years later, Copenhagen researcher Hans Christian Oersted (1777–1851) linked electricity and magnetism, observing that a metal wire carrying electrical current affected a magnetic compass needle. Instead of following Earth's north-south magnetic field, the needle aligned itself with the electrified wire's magnetic field. Oersted's discovery that the electric current had produced magnetism became known as electromagnetism. This new scientific field would become the springboard for development of the electric motor and the electromagnet.

## Making Connections

Inspired by Oersted's discovery, André-Marie Ampère (1775–1836), a Frenchman, set out to explain the connection between electricity and magnetism. Ampère's work led to a much fuller understanding of the relationship between electricity and magnetism, which eventually led to important applications such as the telegraph and electromagnet.

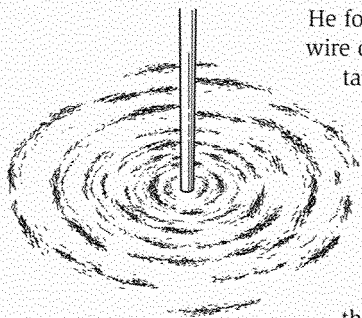

He found that when electricity passed through a metal wire onto a card containing iron filings, and the card was tapped lightly, the filings lined up in a circular pattern around the magnetic field created by the electrified wire. When the electric current was turned off, the filings again relaxed into their random arrangement on the card.

### THE AMPERE

With further experimentation, Ampère discovered that two parallel electric currents running in the same direction attract each other, and that parallel currents running in opposite directions repel each other. The modern unit of current, the *ampere*, was named in his honor.

### Electromagnets

In 1825, William Sturgeon (1783–1850) wound a coil of wire around an iron rod and built one of the first electromagnets. It differed from a permanent magnet as its magnetism could be switched on and off by electrical current.

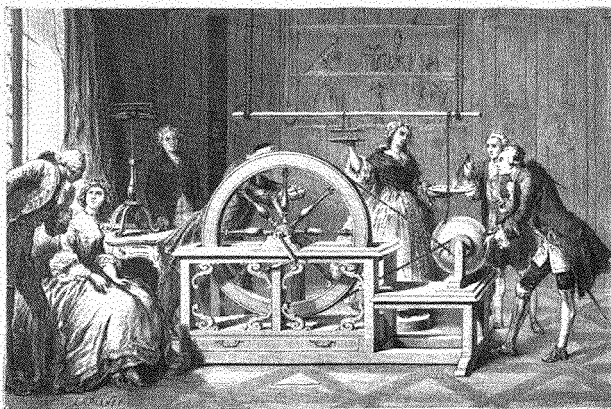

Demonstrations of electricity's properties were of great scientific interest in the 18th and early 19th centuries.

Stephen Gray (1666–1736), a British scientist, figured out that any object that touches an electrified object will itself become electrified. This process—transferring a charge from one substance to another—is known as electrical conduction.





## Important Safety Notes

In your experiments, always use batteries as the power *source*. **Do NOT use electricity from household circuits;**

**it is dangerous and can cause serious injury.** The only exception is for requirement 11e, hooking a model electric train layout to a household circuit. Never work on household *circuits* without first turning off the *circuit breaker* or removing the *fuse*, and *always* work on electricity with the help of an electrician or an otherwise qualified adult.

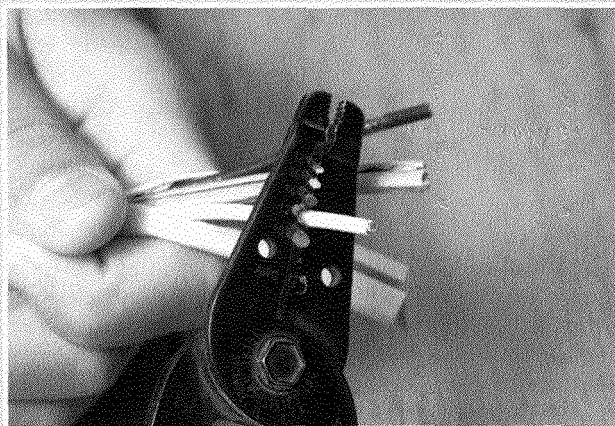

**Wires.** To prepare insulated wires for experiments, you must carefully strip some of the plastic coating (*insulation*) from each end to expose the metal. Use an electrician's wire stripper, or gently cut the plastic with a pocketknife. If you use stranded wire rather than solid-core, twist the strands tightly clockwise.

**Connections.** Join wires and batteries together with electrician's tape, metal paper clips, alligator clips, or mating crimp connectors. Make sure metal parts touch tightly or your experiments will not work.

### Make a Simple Electromagnet

This experiment shows that a wire carrying a current is surrounded by an invisible magnetic field, or force, and it illustrates how closely electricity and magnetism are related.

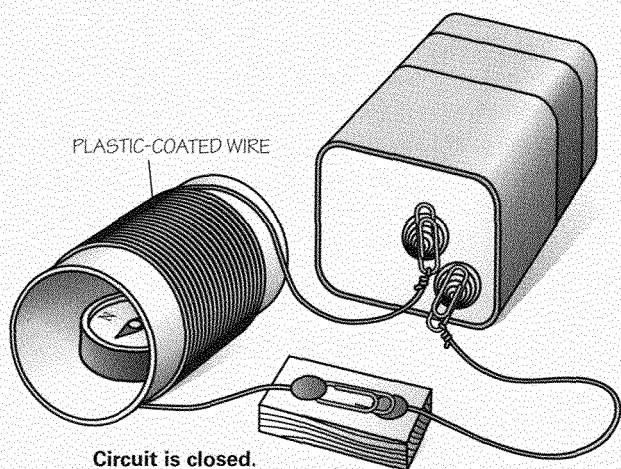

**Step 1**—Wrap a length of insulated (plastic-coated) wire about 20 times around a cardboard tube.

**Step 2**—Connect the wire to a 4.5-volt or 6-volt battery and to a switch.

**Step 3**—Slide a small compass into the middle of the cardboard tube.

**Step 4**—Swivel the paper clip against and away from the thumb-tack to switch the electric circuit on and off.

Watch what happens to the compass needle as you open and close the circuit. When you close the circuit, the electric current produces magnetism in the coil of wire. The magnetism all around the wire makes the compass needle swing. When the circuit is broken (you open the paper-clip *switch*), no magnetism is produced so the needle again points north.

### Magnet Earth

Did you know that you live on what is essentially a huge magnet? Earth, like any magnet, has magnetic north and south poles. What we call the magnetic north pole is located near Bathurst Island, north of Hudson Bay in Canada—more than a thousand miles south of the geographic North Pole. What we commonly call the magnetic south pole is near the Adélie Coast of Antarctica, about 1,600 miles from the geographic South Pole.

## Natural and Artificial Magnets

Magnetic iron ore is found in different parts of Earth. This magnetite, or lodestone, is one example of a natural magnet. In the early Middle Ages, sailors learned that when a slender piece of iron was rubbed on a chunk of magnetite, the iron would become temporarily magnetized. If a piece of hard steel is rubbed on lodestone, the steel will remain magnetized for a long time, becoming a permanent artificial magnet.

Magnets are either permanent or temporary. Permanent magnets are made of hard steel and retain their magnetic effect for a long time. Temporary magnets are made of soft iron or a soft grade of steel and retain their magnetism only when they are in contact with another magnet or are being energized by an electric current.

## Magnetic Attraction and Repulsion

One end of a magnet is its south pole; the other end, its north pole. If you hang a magnet on a string, one end will always point north. You can use a hanging magnet to demonstrate the law of attraction and repulsion. Bring the north pole of another magnet toward the north pole of a magnet on a string. The hanging magnet will spin around until its south pole meets the north pole of the magnet in your hand. Like poles repel each other. Unlike poles attract.

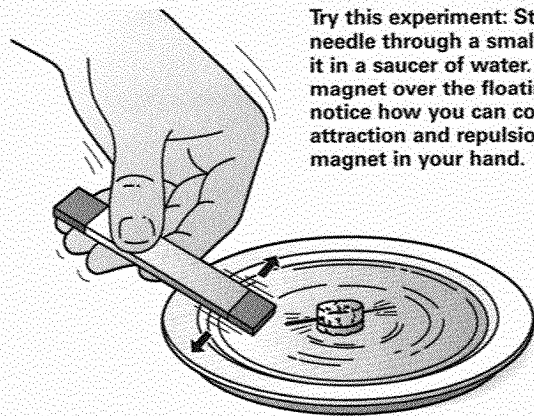

**Try this experiment:** Stick a magnetized needle through a small cork, then float it in a saucer of water. Hold another magnet over the floating needle and notice how you can control it, through attraction and repulsion, by turning the magnet in your hand.

Because of changes in Earth's magnetic field, the magnetic poles are not specific locations but general areas. Studies over a period of many years show that the magnetic poles change location with time.

When you cut off the electric current from an electromagnet, it is no longer magnetized. An electromagnet with a metal core is what operates door-bells, buzzers, CD player speakers, and telegraph instruments.

---

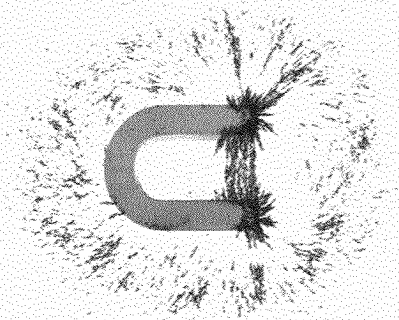

**Iron filings scattered on an index card or stiff paper and held over a horseshoe magnet will arrange themselves like this. The lines are called lines of magnetic force.**

## The Magnetic Field

In the floating needle experiment, you found what seemed like an invisible circle of power around the needle. To actually see this magnetic field, wedge a horseshoe magnet between some books, with the poles facing upward. Balance a card or a piece of stiff paper on top of the magnet, and sprinkle iron filings on the card. Gently tap the card or paper and the filings will arrange themselves in circular forms with a pattern of lines running from pole to pole.



Iron filings can be purchased at a hobby store. Be careful not to breathe or swallow any of them.

## Make an Electromagnet

Now you are ready to make an electromagnet, a magnet activated by the transfer of electricity.

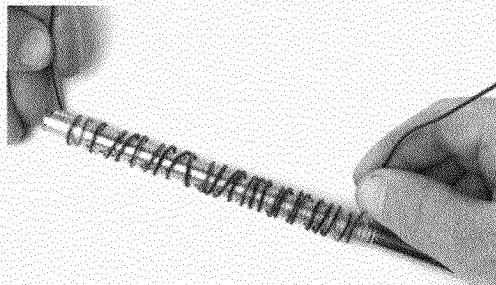

**Step 1**—Coil a length of insulated wire at least 20 turns around a large metal bolt or nail. The more turns of wire around the bolt or nail, the stronger the magnet. Use electrician's tape as needed to hold the coils of wire in place.

**Step 2**—Connect the wire ends to the terminals of a 4.5-volt or 6-volt battery. The electric current will produce a magnetic field, as you know from your experiment with the compass and the cardboard tube. The bolt or nail, now called the core, will become an electromagnet.

Test your electromagnet by using it to pick up metallic paper clips or pins. Try it first with the wire ends connected to the battery, then disconnect the battery. See if the bolt or nail will still pick up paper clips or pins.

### Make a Telegraph Set

To see how an electromagnet can be used to operate devices such as buzzers and telegraphs, make this telegraph set. Then follow the instructions to turn it into an electric buzzer.

#### INSTRUCTIONS

**Step 1**—Nail the two large nails into the block of wood.

**Step 2**—Connect a long piece of wire to one terminal of the 6-volt battery.

**Step 3**—Starting at the top of one nail, wrap the wire around the nail, keeping the coils close together. Coil the wire around and around until the nail is completely wrapped.

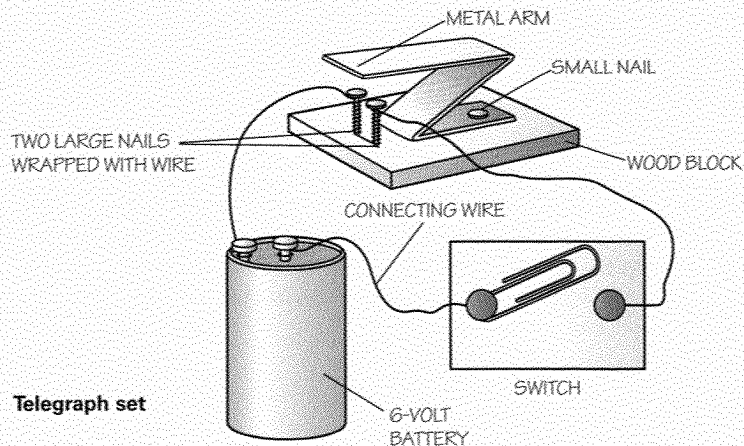

Telegraph set

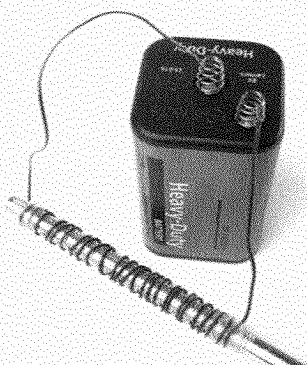

#### Materials Needed

- Two large nails
- Hammer
- Wood block
- Insulated wire
- 6-volt battery
- Switch (wire paper clip)
- Thin strip of unpainted tin or aluminum
- Small nail

**Step 4**—Bring the wire across to the other nail. Working from the bottom up, wrap the wire as many turns as on the first nail.

**Step 5**—Connect the free end of the wire to one terminal of the switch. To complete the circuit, connect a second, shorter wire between the remaining terminal of the battery and the switch.

**Step 6**—Bend a strip of metal into a Z-shape. Use the small nail to attach the metal strip to the block of wood, with the free end of the strip over the two wire-wrapped nails. This piece of metal is the receiver of the telegraph set.

**Step 7**—Close the switch. What does the telegraph receiver do? (If nothing happens, adjust the space between the arm of the metal Z and the two nails. If necessary, bring the metal arm slightly closer to the nails.)

**Step 8**—Open and close the switch several times. Can you signal a message on your telegraph set? Experiment with tapping out short messages.

### **Make a Buzzer**

Next, turn your telegraph into a buzzer.

#### **INSTRUCTIONS**

**Step 1**—Open the switch and make sure it stays open (or disconnect the battery) as you modify the wiring to change the telegraph into a buzzer.

**Step 2**—Use a hammer and a small nail to make a tiny hole in the free end of the metal arm. (To support the metal arm as you hammer, slide a strip of wood between it and the tops of the large nails. Remove the protective wood strip before going to the next step.)

**Step 3**—Cut the wire between the terminal of the 6-volt battery and the first nail. Be careful to cut the wire near the nail.

**Step 4**—Strip the plastic coating from the cut ends of the wire. Connect the wire from the battery to the small hole in the metal arm.

**Step 5**—Curve the free end of the wire sticking out from the top of the nail until it lightly touches the free end of the metal arm.

**Step 6**—Close the switch. Does the buzzer buzz? If not, check the connection of the wire to the hole in the metal arm. Adjust the free end of the wire sticking out from the top of the nail. It is critical that this wire lightly touch the metal arm.

**Step 7**—Open and close the switch several times. How does electric current make the buzzer buzz? Think about what is happening to the circuit—when the circuit is broken, the current stops traveling and the electromagnet loses its power.

## The Speed of Electricity

How fast does electricity travel? Electrons in an electrical current do not travel fast as they jump from one atom to another, pushing other electrons in front of them. But the electrical energy they create travels at nearly the speed of light.

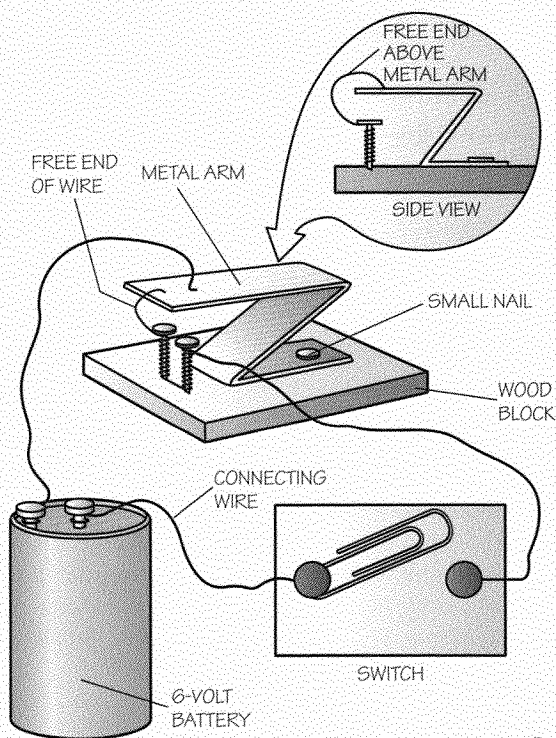

### Materials Needed

- Telegraph set from above experiment
- Hammer
- Small nail
- Wire cutters

**Buzzer**

The word *circuit* refers to the path an electric current travels, from the source of the power, such as a battery, through some device using electricity, such as a lightbulb, and back to the source. If the circuit is opened, or there is no path back to the power source, electrons will not transfer.

## Current Electricity

Current electricity is electricity in motion—the current that runs through a wire and rings a bell or lights a light. What makes the current move? How fast does it travel? In what direction does it go?

### Potential Difference

Every object charged with electricity has a certain potential or electromotive force. When two objects with different potentials are connected with a wire, electrons move from where there are many to where there are few. This is how the transfer of electrons takes place. This potential difference between electromotive forces causes the electrons to travel along the wire attempting to equalize the two potentials until the circuit is opened.

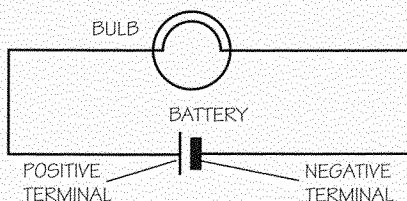

A simple circuit

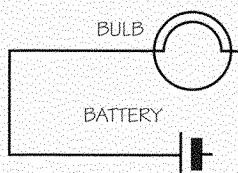

An incomplete circuit

## Electric Batteries

A potential difference exists in electric batteries. In a dry-type battery, like those used in flashlights, the battery's outer edge, or "can," is usually made of zinc, which is negatively charged. A carbon rod in the middle of the battery is positively charged. If you connect the zinc to the carbon with wiring attached to the battery terminals and a device such as a lamp that will use the transfer of current, then the electrons in the zinc will move through the wire and lightbulb into the carbon rod, thus converting chemical energy into electrical energy.



## Dry Batteries

Volta's electric battery created a current of electrons using metal strips to connect a row of cups containing lye in water. One end of each metal strip was silver, the other end was zinc. It was a crude battery, but it worked.

Modern dry cells—commonly called dry batteries—actually have a moist paste, often manganese dioxide, inside. Sizes AAA, AA, C, and D batteries, the sizes used in CD players, flashlights, and other small devices, are 1.5-volt batteries.

Designed for on-and-off use, dry batteries wear down quickly if they are used continuously. Some specially designed batteries can be recharged by passing an electric current through the cells. Not all dry batteries can be recharged, though. A fire or explosion could occur if you attempt to recharge the wrong type of battery.

## Wet Batteries

Wet-storage cells, such as a car battery, should not be used too long without being recharged. If a car radio or headlights are left on all night, you may find the battery dead the next morning. The voltage and the water supply in unsealed wet batteries should be checked regularly and the area around the terminals kept clean. Most modern car batteries are sealed and require no maintenance, but true wet batteries can indeed dry out. Top them off to the fill line with distilled water.

A new type of sealed battery is the gelled electrolyte or "gel cell" battery, which provides a lot of current for its size, is easy to recharge, and is relatively inexpensive. Gel cells are found most often in emergency lighting systems in schools and stores.

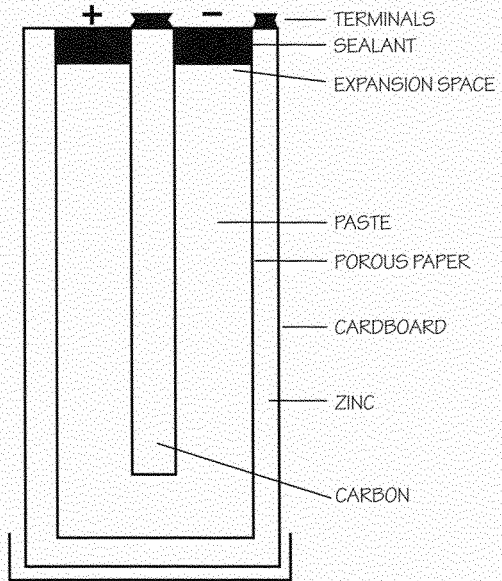

A dry cell is designed for on-and-off use.

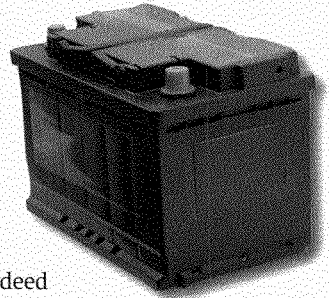

# Common Electrical Terms

To work with electricity, you need to know some common terms for using and measuring it. Several important terms are defined below.

**alternating current.** Current that regularly reverses direction, traveling first in one direction and then in the opposite direction. Power companies generate alternating current to make it easier to transmit electricity over long distances. Abbreviated *AC*.

**ammeter.** An instrument for measuring current in amperes.

**ampere.** A unit measuring the strength of an electrical current, based on the number of electrons transferring past a given point per second. Many elements of a wiring system are rated in amperes for the greatest amount of current they can safely carry. The ampere, abbreviated *amp*, is named for French physicist André-Marie Ampère.



**circuit.** A loop-shaped path through which electric current travels from the source through some device using electricity, such as a light-bulb, and back to the source.

**circuit breaker.** A safety switch installed in a circuit to break the transfer of electricity when the current exceeds a set amount. Circuit breakers can be reset once “tripped.” *See also* fuse.

**conductor.** A substance or device through which electricity passes. Most metals are good conductors of electricity—that is, they allow electricity to travel through them with

little resistance. Gold and silver are the best conductors of electricity but are too expensive for general use. Copper, which is relatively cheap and plentiful, is used most often, especially in transmission lines that carry electricity from power plants to homes, schools, and businesses. Devices that run on electricity have copper or aluminum wiring. Aluminum is not as good a conductor as copper, but because it is cheaper and lighter, it is also frequently used.

**current.** The transfer of electricity in one direction.

**cycle.** One complete reversal of alternating current; a forward current and backward current. Ordinary household current experiences 60 cycles per second (60 hertz).

**direct current.** An electric current of constant direction—that is, the transfer of electrons goes only in one direction. Abbreviated *DC*.

**fuse.** A safety device installed in a circuit to prevent an overload. Designed to melt or “blow” when current exceeds a set amount, it opens the circuit and stops the transfer of electricity. Fuses cannot be reused once blown. *See also* circuit breaker.

**galvanometer.** A device that detects and determines the strength of electrical currents.

**ground.** To connect any part of an electrical wiring system to the ground or to another conducting body, such as a metal water pipe or a metal rod driven into the earth.

**grounding wire.** Conductor that grounds a metal component but does not carry current during normal operation.

**hertz.** A unit of frequency equal to one cycle per second. Abbreviated *Hz*.

**hot wire.** Ungrounded conductor carrying electrical current. Usually identified by black or red insulation.

**insulation.** Covering of nonconducting material used on wires.

**insulator.** A material that does not conduct electricity, such as rubber or plastic.

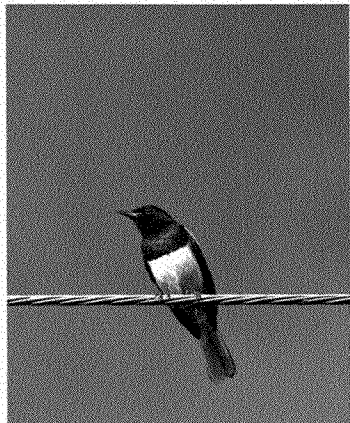

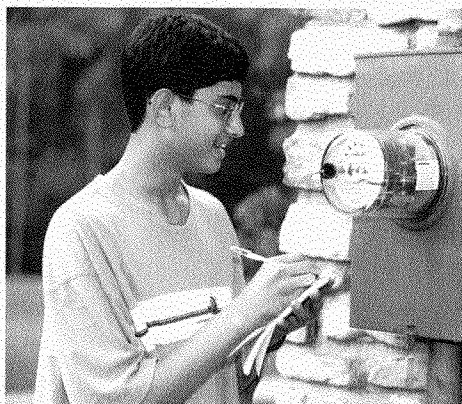

**kilowatt.** Unit of electrical power equal to 1,000 watts. Abbreviated *kW*.

**kilowatt-hour.** Unit of energy used for metering and selling electricity. One kilowatt-hour equals 1,000 watts used for one hour (or any equivalent, such as 500 watts used for two hours). Abbreviated *kWh*.

**load.** The part of an electrical circuit that uses the electric power. In a lighting circuit, the load is the lightbulb.

**neutral wire.** Grounded conductor that completes a circuit by providing a return path to the source. Always identified by white or gray insulation.

**ohm.** A unit of measurement for electrical resistance to a current. It is named for German physicist Georg Simon Ohm (1787–1854), whose Ohm's law states that the pressure of one volt will cause a current of one ampere to flow through a resistance of one ohm ( $\text{Voltage} = \text{Current} \times \text{Resistance}$ ). This simple formula shows the relationship between volts, amperes, and resistance in any electric circuit. Abbreviated  $\Omega$ .



Too many cords are plugged into this outlet.

**outlet.** An electrical device where the switch can easily be connected to a fixture or equipment that uses electricity.

**overload.** Condition in which an electrical circuit carries more current than it can safely handle.

**receptacle.** The device that you plug electric cords into, sometimes called an outlet.

**resistance.** The opposition against the free transfer of electrons in a conductor. Measured in ohms.

**resistor.** A device designed to restrict the transfer of current in (or introduce resistance into) an electric circuit.

**rheostat.** A resistor built so that the current traveling through the circuit can be adjusted at will. Volume controls and dimmer switches are examples.

**short circuit.** A completed, low-resistance circuit that allows electrons to follow a shorter, unintended path back to the power source rather than follow the longer path that goes through the load. Occurs when bare wires touch each other; often results from worn insulation.

**source.** Point of supply, such as a generator or battery.

**switch.** Device to break the transfer of electricity. When the switch is on, the circuit is closed and current may travel through it. When the switch is off, the circuit is open and electricity cannot transfer.

**volt.** A unit of potential difference, or a unit of measurement of electrical pressure or force. Abbreviated *V*.

**voltage.** Pressure at which a circuit operates, expressed in volts. Voltage is like the pressure in a water pipe. For example, 120 volts have twice the pushing force of 60 volts.

**voltmeter.** An instrument for measuring the difference in electric potential (electrical pressure) between two points.

**watt.** Unit that measures electrical power at the point where it is used in a circuit. One watt of power equals one volt of pressure times one ampere of current. Many electrical devices are rated in watts according to the power they consume. Abbreviated *W*.

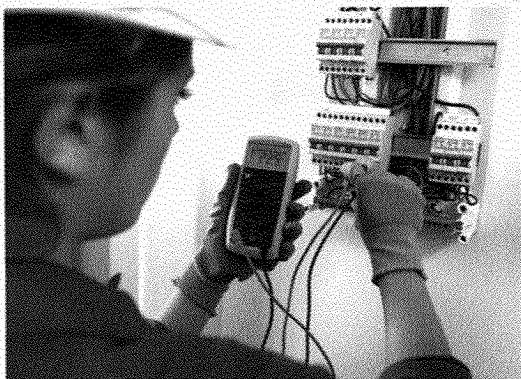

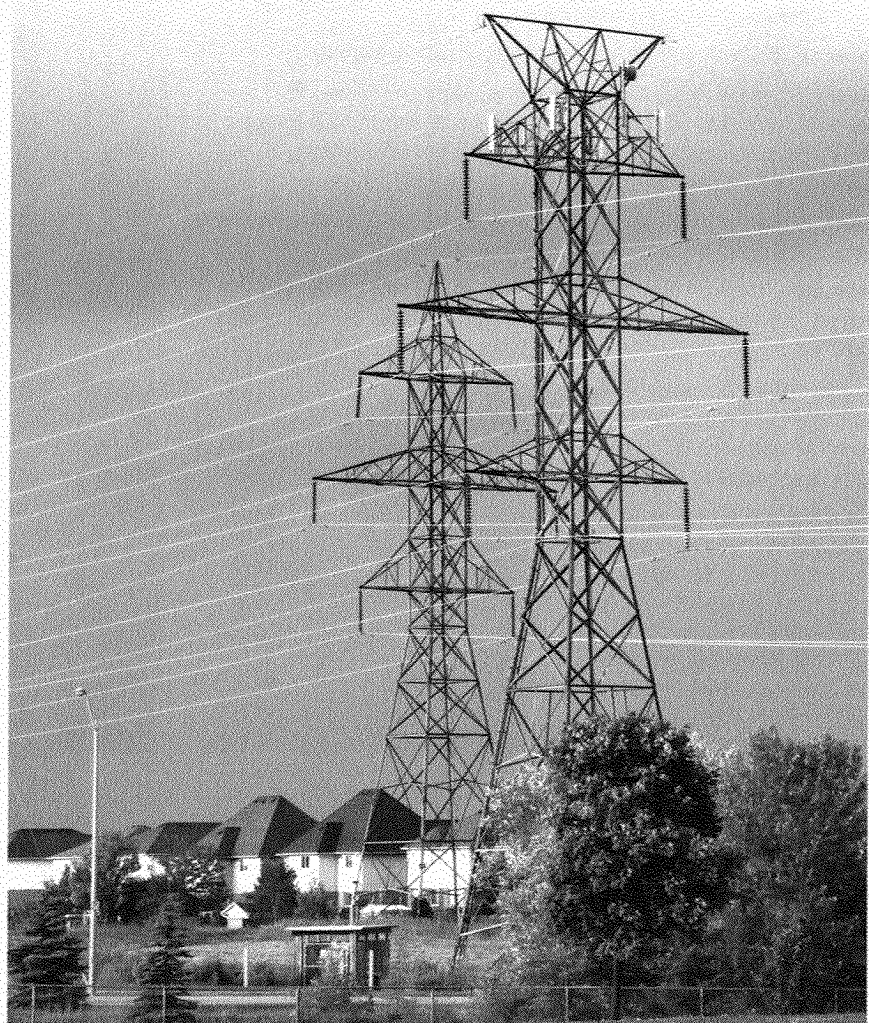

# Current in Motion

Electricity is like an army division. Sitting still, it accomplishes nothing. To get work done, the division must start moving.

Electricity marching along a wire is a valuable servant. We can generate it, send it over wires for great distances, and control it.

## Alternating and Direct Current

There are two kinds of electric current—*direct current (DC)* and *alternating current (AC)*. Direct current is like a one-way street—the electrons go in only one direction. Turn on a flashlight and direct current travels. Car batteries also produce direct current.

In alternating current, the transfer of electrons starts from zero and builds to a peak in the positive direction, then subsides back down to zero. Then the transfer of electrons reverses, building to a negative peak and subsiding back to zero. In this way, electrons alternately travel in positive and negative directions, continuously repeating until the circuit is opened.

Large generators in power plants commonly produce alternating current for use in homes and factories. Most household and industrial power circuits in the United States have alternating currents with a frequency of 60 cycles per second, or 60 *hertz (Hz)*. This means that the current alternates back and forth, making a round-trip, or *cycle*, 60 times per second. To make 60 round-trips, the current changes direction 120 times. Power systems in some other countries operate on a frequency other than 60 Hz. Some appliances depend on the frequency of the alternating current and will not work properly in countries with different frequency electricity.

## Using Alternating Current

Power companies prefer alternating current because it is readily produced by large generators, and it is easy to step its *voltage* up or down. By passing it through simple transformers, operators can easily raise or lower the voltage of alternating current.

---

Power line voltages are extremely dangerous. If you see a downed power line, *do not approach or touch it*. Contact local authorities and the local power company immediately.

---

If mishandled, the electrical current in your house can be dangerous. Do not tamper with power lines. The result could be a fuse blowout, tripped circuit breaker, fire, serious injury, or even death.



When stepped up to a higher voltage, alternating current is easy to transport over long wires. When it arrives at its destination, it is stepped down to moderate voltages. Alternating current readily operates lights, motors, and electrical appliances.

Generators in most electric power plants operate at 13,800 volts or higher. Voltage is passed through transformers that step up the voltage to 34,500 volts or higher. Transmission voltages typically are 115,000, 138,000, and 230,000 volts (called high voltage or HV), and 345,000, 500,000, and 765,000 volts (called extra high voltage or EHV).

---

Transformers do not affect the power; they merely raise or lower the voltage and current.

---

### Transformers

You can raise or lower alternating current voltages by using a transformer. As you raise the voltage, you lower the current in a circuit. As you lower the voltage, you raise the current.

A transformer consists of a round or square iron core. Insulated wire wound around one side of the core is called the primary coil. Wire is also wound around the other side, but with a different number of turns. This is called the secondary coil. The more turns in the secondary coil, the greater the voltage.

Current is put through the primary coil, which induces another current in the secondary coil. If the secondary coil has more turns than the primary coil, the voltage is stepped up. If the secondary coil has fewer turns than the primary coil, the voltage is stepped down.

Here's a definition of voltage classes provided by the American National Standards Institute.

**Low voltage.** A class of nominal system voltages less than 1,000 volts

**Medium voltage.** A class of nominal system voltages equal to or greater than 1,000 volts and less than 100,000 volts

**High voltage.** A class of nominal system voltages from 100,000 volts to 230,000 volts



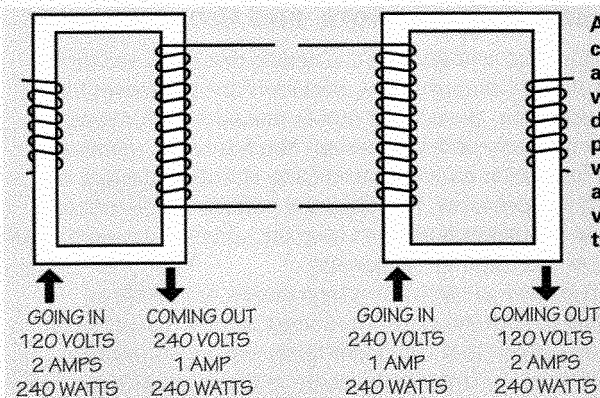

A transformer basically consists of an iron core and two pieces of wire wound around it. To double the voltage, put twice as many windings on one side as on the other. To cut voltage in half, reverse the connections.

### Using Direct Current

While most current produced by large generators is alternating current, direct current can be produced for special needs. Alternating current can be changed to direct current by putting it through a rectifier. You probably have noticed that many small appliances and electronic devices have little black boxes that plug into wall sockets. The black boxes contain voltage transformers and, usually, rectifiers for changing house current (AC) to direct current (DC).

Cars use direct current, as do radios and television sets. Radios and TVs have diodes that act as rectifiers to change the alternating current in your house to the direct current they require. Other uses for direct current include flashlights, electroplating, charging batteries, and separating aluminum from ore.

### Check Your Appliances

Before connecting new appliances or motors, read the metal plate, known as the name plate, that shows what kind of current to use. Some motors and appliances may be wired for direct current or take a voltage higher or lower than the one available. Motors wired for one kind of current can be ruined by connecting them to a different type of current. However, some small motors are wired for both direct and alternating current and are so marked.

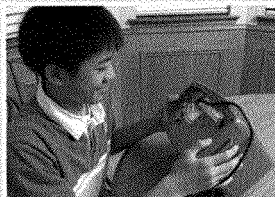

---

Lightning rods are grounded. Can you explain why?

---

## Insulators, Conductors, and Grounds

You know that *conductors* are materials that allow electricity to travel easily through them. *Insulators* are substances like glass, porcelain, plastic, and rubber that have high *resistance* and do not carry ordinary current. You have seen rubber or plastic insulation on wires attached to electronic devices and household appliances. Porcelain and polymer insulators are used on high-tension wires to keep the current from getting out of line or running into the ground.

To *ground* an electrical system means to provide an electrical path to the earth. Grounding assures that all metal parts of a circuit that you might touch stay at zero voltage because they are connected directly to the earth. In a car, the metal frame is the ground. Wires connected to it are considered grounded. The outer parts of the spark plugs are grounded to the engine. One pole of a car battery is grounded to the frame. High-tension wires have elaborate grounding systems in case lightning strikes them, which often happens.

It is crucial to realize that electricity will travel in conductors other than wires. It can travel through any conducting body—including a human body like your own. Make sure electricity does not use you as a conductor on its way to the ground. Water is a good conductor of electricity, so never turn on a light, a radio, or an appliance such as a hair dryer while standing in water—not even on a damp floor.



**NEVER** work on any live electrical circuit, fixture, or appliance. The shock could kill you.

## Electric Motors

Generators and motors are devices that demonstrate the changing of energy between mechanical and electrical. Generators, like portable gasoline generators, take mechanical motion and transfer it to electrical energy, while motors convert electrical input to mechanical motion like turning a fan.

### How an Electric Motor Works

A simple electric motor is little more than a spinning magnet. From your earlier work with magnets, you will remember that

a movable magnet, such as a magnet on a string, swings around because its north pole is repelled and its south pole is attracted by the north pole of a nearby fixed magnet. It will stop turning when its south pole is nearest the north pole of the fixed magnet.

Now, suppose that just as the south pole of the movable magnet nears the north pole of the fixed magnet, we could somehow reverse its magnetic poles. Then it would keep moving for another half turn. If we could change its poles every half turn, the moving magnet would spin around and around.

We cannot reverse the magnet's poles, but we can achieve the same results. In place of a movable bar magnet, we can use a coil of wire wrapped around a core—an electromagnet—that spins. Like a bar magnet, it has north and south poles, but its poles can be instantly changed by reversing the current in the wire. Every time the circuit is opened and closed (once every half turn), the current reverses its direction. This is done automatically as the coil of wire spins around.

### FIELDS, ARMATURES, AND COMMUTATORS

Substitute another electromagnet for the fixed bar magnet, shaped to fit around the spinning coil, and you have a simple direct-current motor. The fixed electromagnet is called the field. The spinning electromagnet is called the armature. The arrangement for opening and closing the circuit is the commutator.

### Make a Motor

You can build a motor by following the steps below.

#### Materials Needed

- |  |  |  |
|--|--|--|
| <input type="checkbox"/> Screwdriver   | <input type="checkbox"/> Hammer and nail   | <input type="checkbox"/> Electrical tape                 |
| <input type="checkbox"/> Wood base<br>(about 12-by-4-by-1/2 inches)                | <input type="checkbox"/> Piece of cork (3 to 4 inches long)                          | <input type="checkbox"/> Battery (C, 6V, or 9V)          |
| <input type="checkbox"/> Four small screws   | <input type="checkbox"/> Two pieces of thin insulated copper wire (bell wire)        | <input type="checkbox"/> Rubber band                     |
| <input type="checkbox"/> Two metal L brackets (about 1 1/2-by-1 1/2-by-1/2 inches) | <input type="checkbox"/> Sturdy, thin wooden or plastic dowel (about 10 inches long) | <input type="checkbox"/> Four to six small stick magnets |
|  |  | <input type="checkbox"/> Wire stripper                   |

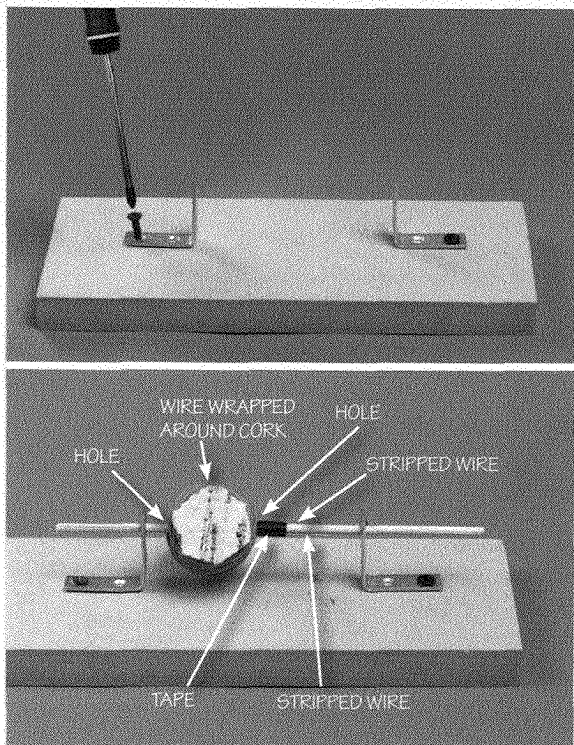

## INSTRUCTIONS

**Step 1**—With a screwdriver, attach the L brackets to the wood base. Be sure the brackets are spaced far apart enough to allow room for the dowel to fit through the two holes at the top, and for the cork-dowel assembly to spin freely. About 1 inch of the dowel should reach past each support.

**Step 2**—Use the hammer and nail to punch a hole in the cork crosswise, as shown. Be sure the hole is large enough for the dowel and wire to pass through. With the cork in place, the dowel must be clear of the wood base and be able to turn freely in its support.

**Step 3**—Cut a piece of the insulated wire about 60 inches long, and wrap it around the cork about 15 to 20 times. Do not cover the holes in the cork or cut the wire—use one continuous length of wire. (The more wraps there

are, the “stronger” the motor will be.) Leave several inches for leads on each end of the wire, and pass both ends through the hole in the cork.

**Step 4**—Using the wire stripper, remove about a half-inch of insulation from both ends of the wire. Insert the dowel in the cork. Tape the leads of the wire to opposite sides of the dowel, as shown. Do not let the stripped ends touch each other or cover them with tape.

**Step 5**—Screw two more screws into the wood base, as shown, but leave enough space between the screw and base to wrap wire around it once. Cut a piece of wire about 12 inches long. Remove about a half-inch of insulation from both ends of the wire. Wrap the wire across the top and bottom of a C battery, as shown, and secure in place using a rubber band. Then wrap each end of the wire once around the screws, and position the ends against the dowel, on opposite sides, so that the ends connect with the bare wire mounted on the dowel.

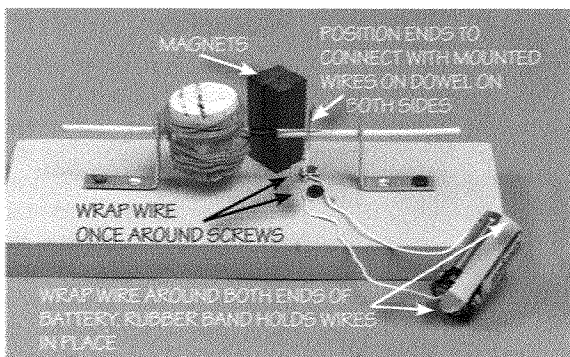

**Step 6**—Position the magnets as shown, close to the connections. Give the dowel a spin with your fingers. The motor should now spin on its own. If it doesn't work, you may need to move the magnets slightly back and forth to find the "sweet" spot. Then try again, moving the magnets slightly back and forth, up and down, until the motor starts spinning.

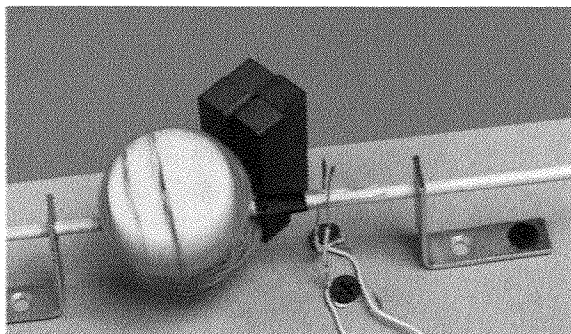

If you are using a 6V battery, connect the wires to the terminals, as shown here. The same concept applies for a 9V battery, but you will need to use a rubber band to secure the wire to the battery for a good connection.

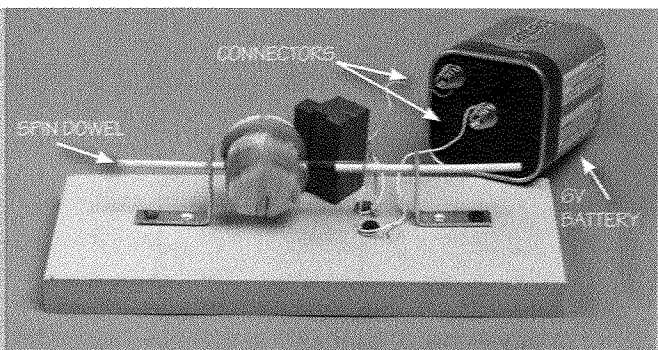

## Rheostat

A *rheostat* is a simple device used to control the electrical current in a circuit by inserting a length of high-resistance wire or other resistive material. The resistance of a rheostat is measured in *ohms* and determined by the size and length of the resistive wire.

Rheostats are used as volume controls in radios and television sets. They are also used in dimmer switches to control the intensity of lighting in a room. You have probably seen a dimmer switch used in a theater or auditorium to brighten or dim the lights gradually. A rheostat might also be used to slow down or speed up a model electric train.

It is important to remember three rules about resistance:

- A thin wire offers more resistance than a thick one. Just as it is harder to force water through a small pipe than through a big pipe, it is more difficult for electricity to travel through a small wire than a larger one.
- A long wire offers more resistance than a short one, just as a long pipe slows the flow of water.
- Electricity tends to seek the path of least resistance.

## Make a Rheostat

You can make your own rheostat by following these instructions.

### Materials Needed

- |   |  |
|---|--|
| <input type="checkbox"/> Flashlight battery | <input type="checkbox"/> Full length of pencil lead from a mechanical pencil |
| <input type="checkbox"/> Flashlight bulb    | <input type="checkbox"/> Thin copper wire                                    |
|   | <input type="checkbox"/> Transparent tape                                    |

Pencil lead makes a good rheostat because it is not a good conductor of electricity. The greater the distance between the battery and the bulb, the weaker the current becomes. A rheostat is a variable *resistor* used to control current.

**INSTRUCTIONS**

**Step 1**—Attach the wire to the top of the battery.

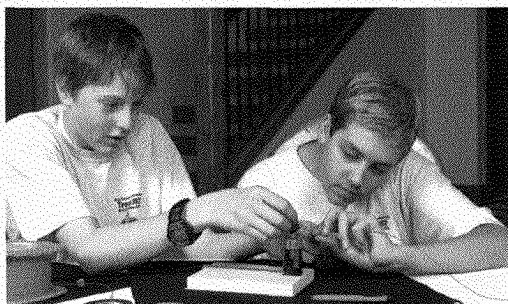

**Step 2**—Twist the other end of the wire around the metal side of the lightbulb.

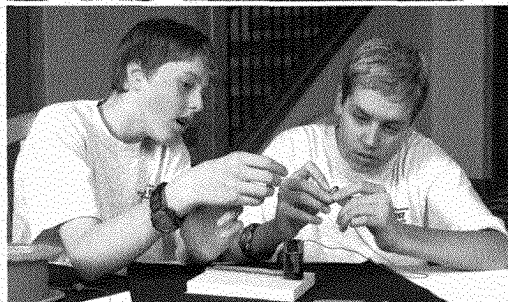

**Step 3**—Holding the lightbulb by its glass end, touch the metal bottom of the bulb to the lead close to the battery as shown. The bulb will burn brightly.

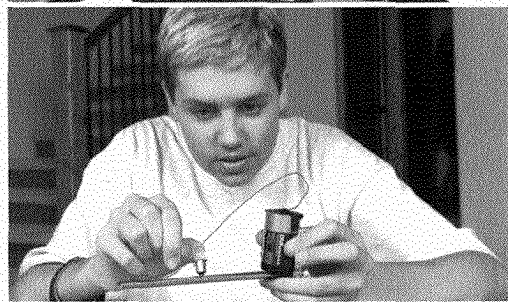

**Step 4**—Gradually slide the bulb down the length of the lead. The bulb will slowly grow dimmer as it is moved away from the battery.

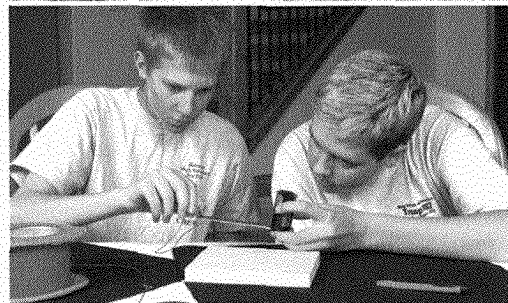

Keep extra fuses handy.

## Fuses and Circuit Breakers

Electric current comes into your home on overhead or underground wires. From your electrical meter, heavy, well-insulated wires run to a main distribution center or breaker box, where the main disconnect switch is located. If necessary, you can use that switch to shut off all electric current in your house.

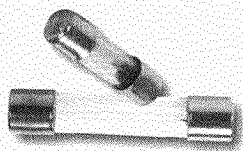

The fuse box or circuit breaker panel is typically located in a utility room, in an electric room, in a mechanical room, or near the main power feed to the building. Fuses and circuit breakers act as guards: They prevent currents that are too strong from traveling into your home's branch circuits. If the transfer of electricity becomes greater than a fuse is designed to handle, the metal element inside the fuse melts and the fuse



### Dos

- Employ professional, licensed electricians for major electrical work.
  - Promptly replace worn cords and defective plugs.
  - Open the main disconnect before replacing fuses.
- Keep electrical cords where people will not trip over them.

### Don'ts

- Don't plug in too many appliances or devices into one *outlet* or one circuit. The *overload* may blow a fuse, trip a circuit breaker, or start a fire.
- Don't pull out cords by the wire. Take firm hold of the plug instead.
- Never touch electrical devices while in the tub or while touching faucets, water pipes, or radiators.
- Don't let Christmas tree lights touch the needles of the tree.
- Never leave Christmas tree lights burning if you are not home.
- Never work on any live electrical circuit, fixture, or appliance.
- Don't replace a blown fuse with one that has a higher ampere rating.
- Never stand on a damp floor when replacing fuses or handling electrical devices.
- Don't operate fans or heaters where small children can reach them, and don't leave these appliances running unattended.



blows, or burns out. A circuit breaker automatically opens and “trips” the circuit.

Every time you switch on another light or appliance, more current travels through that branch circuit. The wire is heavy enough to carry amperes for normal use. If there are too many amperes, the wires may get hot and start a fire unless a fuse or circuit breaker protects the line.

If a fuse is designed to carry up to 15 amperes, for example, and you try to consume 25 amperes from that line, the fuse blows, the lights go out, and you know you have overloaded the circuit. First, correct the problem so you will not overload the circuit again. If you have too many appliances plugged into one outlet or one circuit, unplug them. Toasters, coffeemakers, irons, and heaters can use a lot of current. They frequently are the culprits.

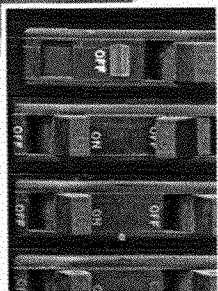
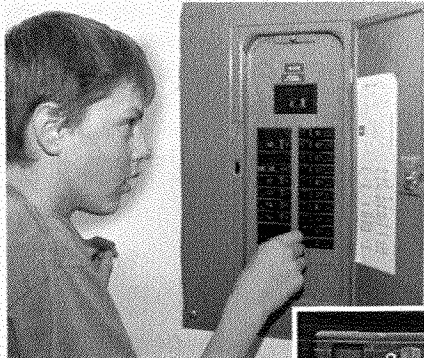

### Short Circuits

One common cause for a blown fuse or tripped circuit breaker is a defective or frayed cord. Insulation wears off and the bare wires *short-circuit*. A flash of light and a smell of burning insulation indicate a short circuit. In a short circuit, electrons can follow a shorter, unintended path back to the power source rather than the longer path that goes through the appliance or other device using electricity. Since the current suddenly encounters lower resistance, more current transfers, and that blows a fuse or trips the circuit breaker.

Some circuit breakers used in homes are the push-push type; others have a handle that must be pushed to the off position before the breaker can be reset to the on position. Follow the instructions on your home's circuit breaker panel to properly reset whatever type you have.

### Fuse Boxes

Fuse boxes have not been used in home or business construction for many years. However, you might encounter a fuse box in an older building. In a fuse box, there will be several fuses. Before you replace one, open the main disconnect for

---

When a fuse blows or a circuit breaker opens a line because of excessive current, you must first correct the cause of the problem. Then replace the fuse or reset the circuit breaker.

---

safety. The blown fuse probably will look black or show a gap. Unscrew the burned one and replace it. If you can't tell which fuse is blown, check each one. Each fuse is marked to show how many amperes it will carry. Never use a fuse of higher amperage than the one you take out—it could start a fire.



Damp floors can be a shock hazard. If a room in your home has a damp floor, power should be disconnected and the problem fixed before returning electric power to the room.

## Series and Parallel Circuits

In a series circuit, electric current travels along a single path, going through each component or device. If one component is removed or fails (as when a series-wired Christmas tree bulb burns out), the circuit is broken and electric current stops.

In a parallel circuit, each component or device is connected to the power source on its own branch of the main circuit. Even if one bulb in a parallel circuit burns out or is removed, the other bulbs continue to work because each has its own complete circuit. The wiring in a house is arranged on parallel circuits. If you switch off one device, the others still work.

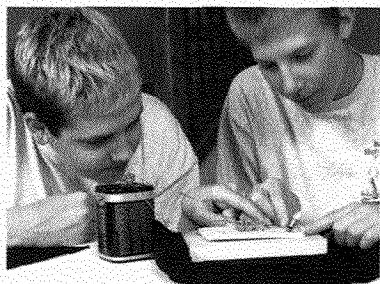

## Switches

A single-pole, single-throw switch is commonly used to turn on electric lights and many other devices. It also is one of the easiest electrical items you can make for a home experiment. It is simply a strip of metal that swings, making contact with a round-headed screw. A metal washer at the fixed end of the switch is suggested.

## Electric Bell

For part of requirement 5, you will need to draw a simple electric bell to show how it works. Look at the drawing of the electric bell on the following page.

Stairways often have lights that can be controlled by switches at both the top and bottom of the stairs. This requires a single-pole, double-throw—or three-way—switch in each position.

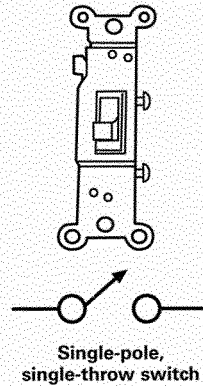
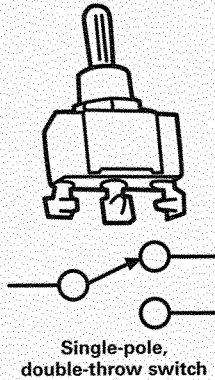

First, follow the path the current takes. When you push the button, the current goes through terminal A to the electromagnet F. From there it goes to a moving contact, C, then to contact post D, and out terminal E.

How does the current cause the bell to ring? As you push the button, the electromagnet F attracts a small piece of iron (the armature), B. Attached to the armature are contact C and a hammer, H. The hammer hits the gong. As the armature is pulled to the magnet, it pulls the contact away from post D and the current stops—the circuit is broken. Thus, the electromagnet loses its power and the spring G snaps the armature and contact C back to post D. As contact C touches the post, the current starts transferring again and the entire process is repeated. This will happen several hundred times per minute, creating the sound of a ringing bell or vibrating gong.

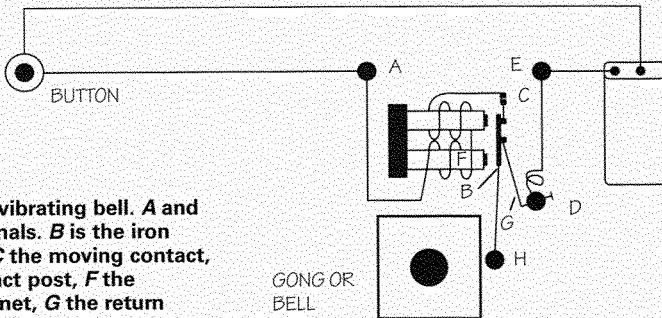

An electric vibrating bell. A and E are terminals. B is the iron armature, C the moving contact, D the contact post, F the electromagnet, G the return spring, and H the hammer.

GONG OR BELL

### Connect a Model Train to a House Circuit

If you choose requirement 11e, you must show how to safely hook up a model electric train layout to a house circuit. You should know several things about your electrical power supply before you plug in the electric train transformer or attempt to operate your electric train.

Never connect your train directly to an electrical outlet. Always use an electric train transformer, which changes the higher voltage electric power (usually 115 to 120 volts) found in your home to the low voltage required for operating toy trains (from 8 to 18 volts).

The transformer cord is plugged into any convenient wall outlet. Low voltage is then obtained from the binding posts on top or in back of the transformer.

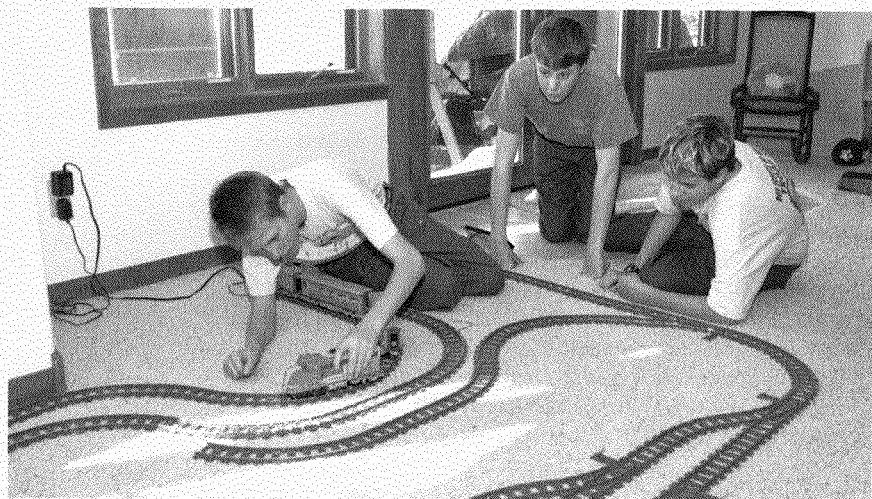

Remember that household lines in different countries might not be alike. Make certain that the voltage and frequency (cycles) of your electric power supply correspond to the rating of the transformer. If you have any doubt, ask the local electric company.

Do not plug your transformer into direct current (DC) as it will burn out immediately and may cause a fire hazard. Most regions of the United States and Canada have alternating current (AC). DC in household current is rare.



## Electrical Safety Inspection

For requirement 2, you will need to complete an electrical safety inspection of your home. Here are some items you can check in your home today to ensure electrical safety. These tips come from the Electrical Safety Foundation International and can be found online at <http://www.esfi.org>.

Make an electrical safety checklist and walk through each room of your house, checking on each aspect of electrical safety. You can go over your list with your counselor later and discuss what you found.

**Outlets.** Check for outlets that have loose-fitting plugs, which can overheat and lead to fire. Have an adult replace any missing or broken wall plates. Make sure there are safety covers over unused outlets that are accessible to children.

**Cords.** Make sure cords are in good condition and not frayed or cracked. Make sure they are placed out of traffic areas where people can trip over them or small children can reach them. Cords should never be nailed or stapled to the wall, baseboard, or another object. Do not place cords under carpets or rugs or put furniture on top of them.

**Extension Cords.** Check to see that cords are not overloaded. Extension cords should be used on a temporary basis; they are not intended as permanent household wiring. Make sure extension cords have safety closures to help prevent small children from electrical burns on their mouths and other injuries.

**Plugs.** Make sure your plugs fit your outlets. Never remove the ground pin (the third prong) or try to make a three-prong plug fit into a two-conductor outlet. This could lead to an electrical fire. Never force a plug into an outlet if it does not fit. Plugs should fit securely into outlets. Avoid overloading outlets with too many appliances.

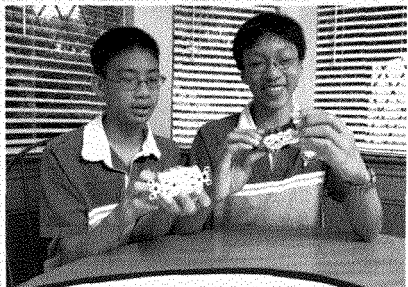



---

## Underwriters Laboratories

**Inc. (UL)** is an independent, not-for-profit product safety testing and certification organization.

A UL label or stamp (*above*) means that the product meets nationally recognized safety standards. Look for this label when purchasing any electrical products.

---

**Ground Fault Circuit Interrupters (GFCIs).** GFCIs can help prevent electrocution. They should be used in any area where water and electricity may come into contact. When a GFCI senses current leakage, it assumes a ground fault has occurred. It then interrupts power fast enough to reduce the chance of serious injury from electrical shock. Test GFCIs frequently according to the manufacturer's instructions and after major electrical storms to make sure they work properly.

**Lightbulbs.** Check the wattage of all lightbulbs in light fixtures to make sure they are the correct wattage for the rating of the fixture and any interconnecting wires. Replace bulbs that have a higher wattage than recommended. If you do not know the correct size, check with the manufacturer of the device. Make sure bulbs are screwed in securely; loose bulbs can overheat.

**Circuit Breakers/Fuses.** Circuit breakers and fuses should have the correct size current rating for the circuit wiring and intended purpose. If you do not know the correct rating, have an electrician identify and label the rating to be used. Always replace a fuse with one of the same rating. Make sure everyone in your family knows where the main breaker is located and how to shut off power to your entire house in case of emergency.

**Plug-In Appliances.** Check to make sure plug-in appliances such as hair dryers are not left plugged in where they can come into contact with water. If a plug-in appliance falls into water, NEVER reach in to pull it out, even if it is turned off. First, turn off the power source at the fuse box or breaker panel, and then unplug the appliance. If you have an appliance that has gotten wet, do not use it until it has been checked by a qualified repair person.

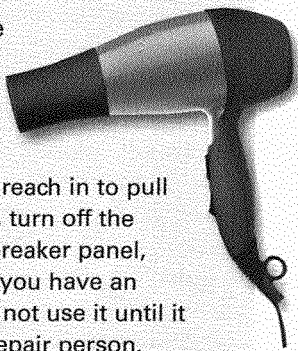

**Appliances.** If any appliance repeatedly blows a fuse or trips a circuit breaker, or if it has given you an electric shock, unplug it and have it repaired or replaced.

**Entertainment/Computer Equipment.** Check to see that the equipment is in good condition and working properly. Look for cracks or damage in wiring, plugs, and connectors. Always use a surge protector bearing the seal of a nationally recognized certification agency to protect your electronic devices from unexpected bursts of voltage that could otherwise cause damage.

**Outdoor Safety.** Electric lawn mowers and electric power tools should not be used in rain, on wet grass, or in wet conditions. Inspect power tools and electric lawn mowers before each use for frayed power cords, broken plugs, and cracked or broken housings. If a tool is damaged, stop using it immediately. Repair or replace it. Always use an extension cord marked for outdoor use and rated for the power needs of your tools. Unplug all portable power tools when not in use. When using ladders, stay away from overhead wires and power lines. Making contact with power lines can cause serious injury or death.

**Lightning.** During electrical storms, do not use appliances such as hair dryers, toasters, radios, or telephones, except in an emergency. Do not take a bath or shower. Keep batteries on hand for flashlights in case of power outages. Use surge protectors on electronic devices, appliances, telephones, faxes, and modems. The best protection is to unplug electrical equipment during an electrical storm.

**Space Heaters.** Space heaters are meant to supply supplemental heat. Keep space heaters at least 3 feet away from combustible materials such as bedding, clothing, draperies, furniture, or rugs. Do not use them in rooms where children are unsupervised. Turn off and unplug space heaters when they are not in use. Do not use space heaters with extension cords. Plug the heater directly into an outlet of a relatively unburdened circuit.

**Halogen Floor Lamps.** Halogen floor lamps operate at much higher temperatures than standard incandescent lightbulbs. Never place a halogen floor lamp where it can come into contact with drapes, clothing, or other combustible materials. Be sure to turn the lamp off when you leave the room and never use these types of lamps in children's rooms or playrooms. Consider cooler fluorescent floor lamps.

## Electrical Floor Plan of a Room

For requirement 8, you will need to draw a simple floor plan of a room in your house with lights, switches, and electrical outlets penciled in.



First, make a drawing that shows the outlines of a room in your house. Then use the electrical wiring symbols to draw in the overhead and wall lights and to show where electric switches and electrical outlets are located.

Next, ask a parent or guardian to go to the main breaker box and turn off the circuit that supplies power to the room you have chosen. Turn on the lights in the room before the adult flips off the circuit breaker. If there is more than one circuit breaker that corresponds to the room, note which breaker supplies power to what outlets, lights, and switches by checking them while the power is off.

To the side of your room drawing, make a box and highlight the circuit breakers that supply power to the room. Briefly note which breaker supplies power to the various electrical devices in the room. You may also want to note the size fuse or fuses with which the room operates. Ask a parent to check the fuse size at the breaker box.

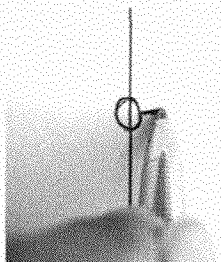



## Electrical Wiring Symbols



Ceiling outlet



Single-pole switch



Floor outlet



Double-pole switch



Two-wire cable or raceway



Three-way switch



Three-wire cable or raceway



Galvanometer



Four-wire cable or raceway



Resistor



Push button

Single-pole,  
single-throw switch

Buzzer



One-cell battery



Bell



Multicell battery

Chime (also **CH**)

Ammeter



Motor



Bulb



Junction box



Bulb in bulb holder



Ground connection



Voltmeter

## How to Read an Electric Meter

A watt-hour is a unit of energy. Electric companies charge their customers on the basis of *kilowatt-hours (kWh)* used. Kilo is the Greek word for one thousand. Thus, a kilowatt-hour is 1,000 watt-hours. One kilowatt-hour equals 1,000 watts used for one hour (or any equivalent, such as 500 watts used for two hours). The electric meter at your house measures kilowatt-hours; an electric bill shows the cost of the number of kilowatt-hours used in a given period of time.

As part of requirement 9, you must learn how to read an electric meter. Locate the electric meter at your home or apartment. It will be either the digital display type or a traditional dial meter.

If you have a dial meter, it is not hard to learn how to read it. Reading the dials from left to right, simply write down the figure that the hands or pointers have just passed. When a pointer is between two numbers, you always write down the smaller number. If the pointer is exactly on a number, write down that number.

A *watt* is a unit of power that measures electrical power flowing through a circuit. It was named for James Watt (1736–1819), a Scottish inventor who perfected the steam engine.

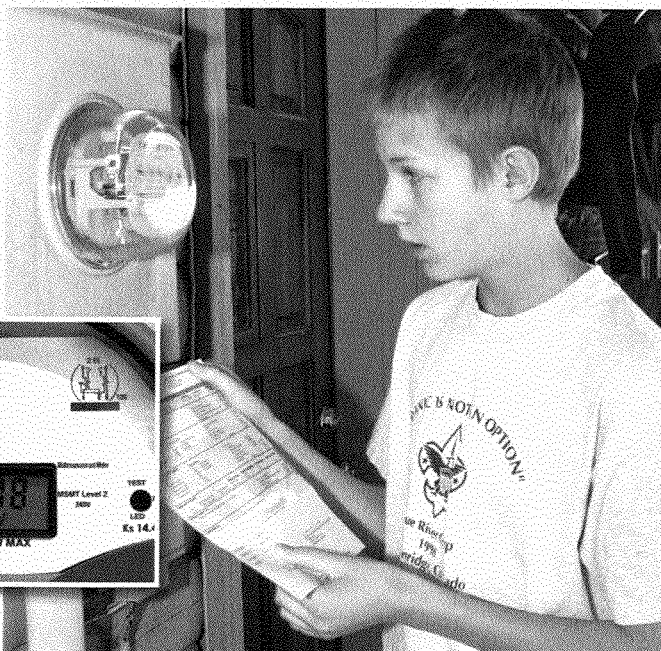
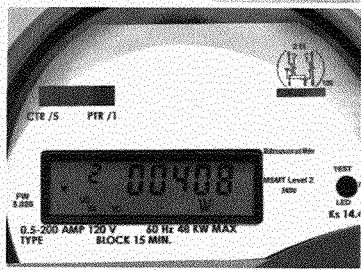

## Reading a Meter

Beginning with the left-hand dial in the illustration that follows, notice that the last figure passed by the pointer is 1. On the next dial, the pointer has passed 7. (Some of the dials read clockwise, others read counterclockwise. The pointer on this dial goes counterclockwise.) The third dial has passed 5. On the fourth dial, the pointer is between 9 and 0. Consider 9 in this case to be smaller than 0 because the 0 is really a 10. Also, you always write down the number the pointer has just passed, not the number it is moving toward. The final pointer is exactly on 2. The meter reading is 17592.

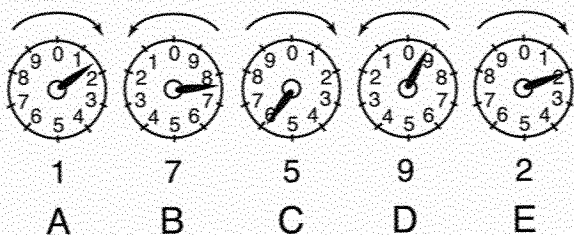

When a pointer on any of the meter dials is between two figures, always note the smaller number.

If you are not sure a pointer has passed a figure, see if the pointer to the right has passed zero.

To find out how many kilowatt-hours you used at your house in one month, subtract last month's reading, which can be found on your last electric bill, from this month's reading. For example:

Dial	A	B	C	D	E	
Present reading	1	7	5	9	2	
Last month's reading	1	6	6	0	2	
Kilowatt-hours used				9	9	0

To figure out your electric consumption during any period of time, simply subtract the reading taken at the beginning of the period from the reading taken at the end of the period.

### Determining the Cost of Electricity

To figure out how much your electricity bill will be, you must know how much your electric company charges per kilowatt-hour. You can find this out by looking at your family's electric bills. If the bill does not show a price per kilowatt-hour, you can get a close estimate by dividing the amount of the bill by the kilowatt-hours used.

For example, an electric bill of \$124.32 divided by 1,110 kWh works out to \$0.112 (slightly more than 11 cents) per kilowatt-hour. If your electric company charges 11 cents per kilowatt-hour, the bill for 990 kWh (in the earlier meter-reading example) would be  $990 \times 0.11 = \$108.90$ .

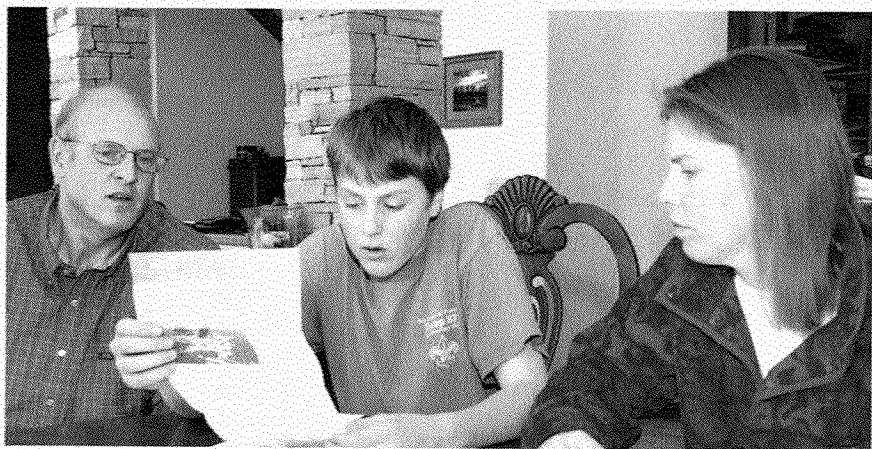

Note that the dials give readings in multiples of 10. The dial farthest to the right shows kilowatt-hours in single digits, the next dial in tens, the next dial in hundreds, then thousands, and the leftmost dial in ten thousands.

As you saw earlier, the hands on the dials of a meter turn either clockwise or counterclockwise. The pointer on the dial to the right must make a complete revolution, that is, reach zero, before the pointer on the next dial will move one space, and so on.

## Conserve Energy, Reduce, Use

Consider how your family could conserve energy and reduce your electric bill, then share your thoughts with your counselor. The five keys to good energy management are:

1. Know your electric utility rates.
2. Know how much energy you are using.
3. Know where you are using the energy.
4. Know when you are using the energy.
5. Implement simple energy-management techniques.

Here are some ideas.

**Turn off lights and electronic equipment after use.** Set the air conditioner at 78 degrees during summer months and the furnace at 68 degrees in winter. If you are too cold or too warm, layer your clothing up or down accordingly. Turn off the heat and open windows on days when the temperature is over 65 degrees. On cool summer days, turn off the air conditioner.

**Clean or replace heating and air-conditioning filters at least once a month.** Filters clogged with dust and air pollutants make air-conditioning and heating your home less efficient.

**Install low-voltage outside lights.** Installing 7-volt lights on the exterior of your home will save you money.

**Do full loads of laundry.** You can conserve water and electricity and lower your electric costs by washing only full loads of laundry.

**Grill food outside.** Using an outdoor grill in good weather will minimize use of the electric oven and stovetop.

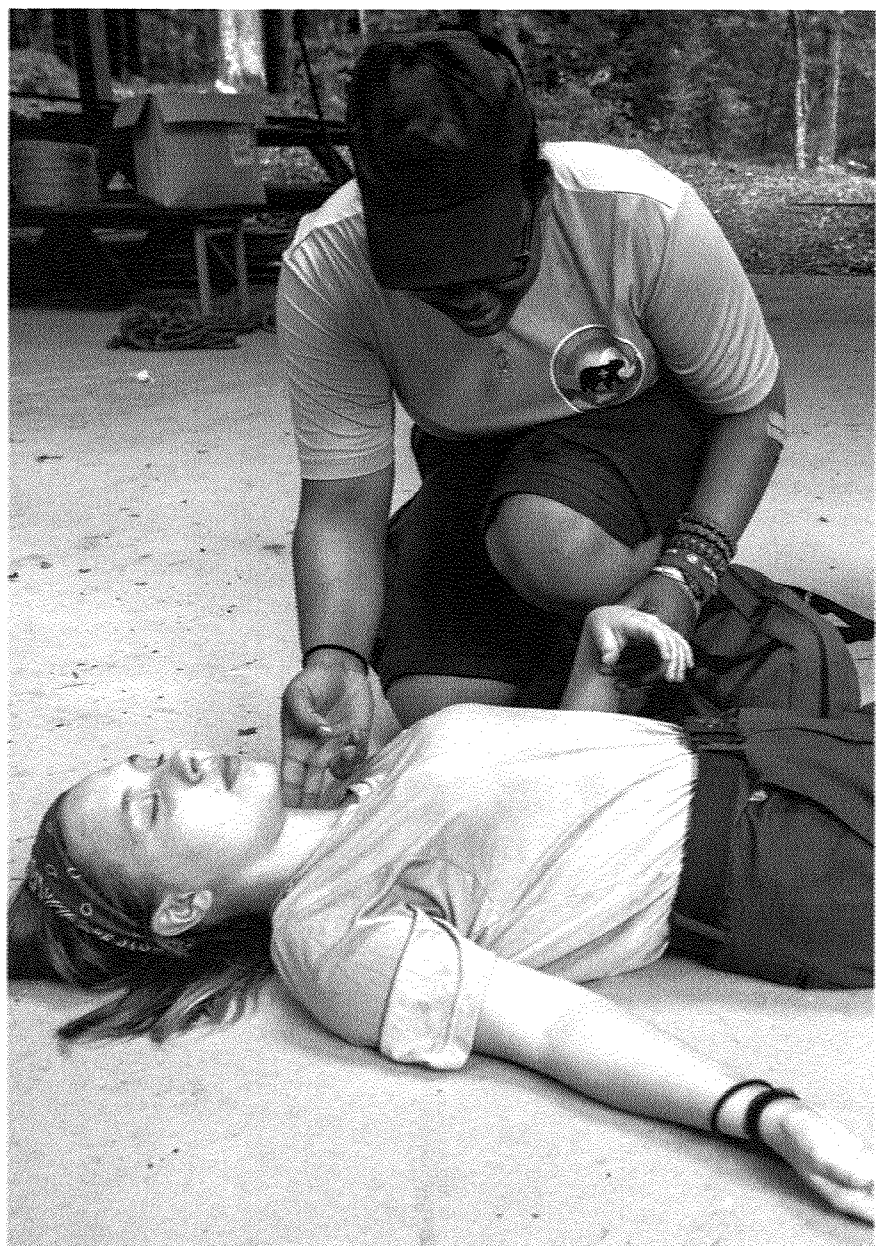

# Responding to Electrical Emergencies

Electrical outlets and wires pose the greatest danger to young children. Preschoolers love to insert hairpins, paper clips, and any number of other conductive objects into electrical sockets. Toddlers often explore electrical outlets and wires by mouthing them. Since water is an excellent conductor of electricity, there is a danger of severe facial burns.

When not in use, electrical outlets should have protective guards plugged into them or be hidden and hard to reach behind furniture.

## Electric Shock

Electric shock is caused by electric current passing through a human body. The victim's breathing may stop and the person's body may appear stiff. The electric contact must be broken as quickly as possible.

If someone is in contact with a live circuit, **do not touch the person**. You can become "stuck" to the person and part of the electrical field. If the service panel is nearby, quickly shut off the house current by throwing the main disconnect switch. If it is a long way to the service panel, or you do not know where the main disconnect switch is, use a nonconducting object such as a wooden chair, wooden broom handle, rug, or rubber doormat to separate the person from the live wire. Never use a metal or wet object.



Under no circumstances should you ever touch a victim or an electric wire with your bare hands while the person is still in contact with the electrical source.

Keep in mind that both water and metals can conduct electricity. If you are trying to rescue a person touching a live wire, stand on something dry and nonconducting like a rubber mat or wooden stool.

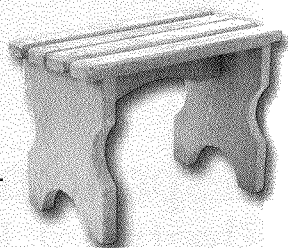

If you can't separate the victim from the wire using something like a broom handle, make sure you are standing on a perfectly dry surface and use a dry towel, sheet, sweater, or other heavy cloth to encircle the wire where it is not wet or bare. Pull the wire from the victim. **Never directly touch the wire or the victim.** Don't touch grounded objects like pipes under a sink.

If you can't remove the wire, your final alternative is to use a cloth to pull the victim from the wire. Without touching the person, carefully loop a sweater or other piece of clothing around the victim, and grasping the ends of the clothing, pull the person away. You might have to pull some distance before breaking contact with the wire. Do not touch the victim directly until the victim and the wire are separated.

If the person is not breathing after the rescue, start artificial respiration immediately. Call 911 for medical assistance.

## High-Voltage Power Lines



Rescuing a person in contact with a live power line outdoors is extremely dangerous and should not be attempted by a Scout. Call 911 immediately and let the fire department and police handle that type of emergency. Also, do not get within 20 feet of someone who is being electrocuted by high-voltage electrical current until the power is turned off and a utility or safety worker declares the area safe.



## Treating Burns

Unless there is immediate danger, do not move a victim of electrical injury. Do not apply ice, butter, ointments, medication, bandages, or cotton dressings to electrical burns. Do not touch burns, break blisters, or remove burned clothing. Electric shock causes burns inside the body, so immediately seek medical attention for the victim.

Once you and the victim are securely away from the electrical source, check the person's wrist and jugular vein in the neck for a pulse. If the victim is not breathing, start artificial respiration right away.

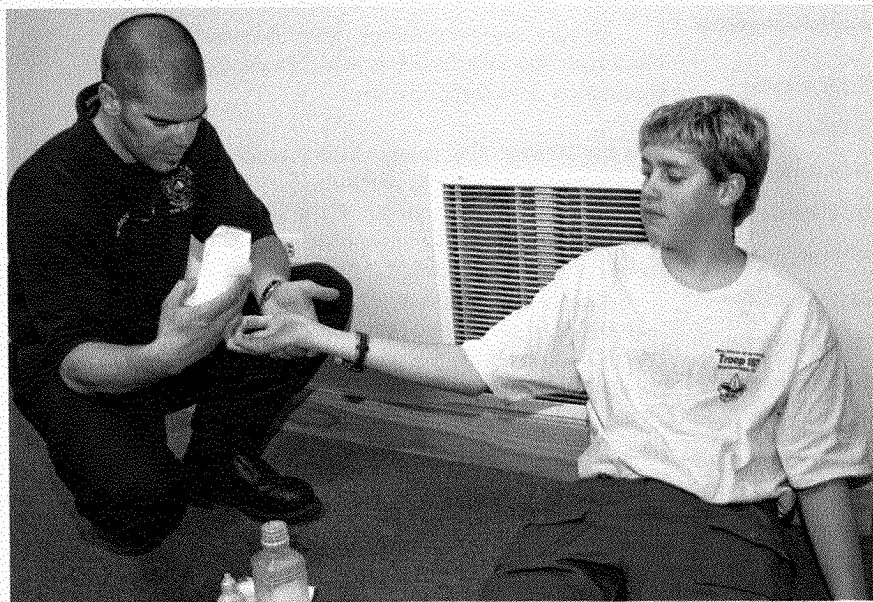

## Life-Threatening Emergencies

The correct first aid given quickly can save a life. A person who has stopped breathing must receive rescue breathing within three to five minutes or brain damage will occur. People who may need lifesaving first aid include victims of lightning strikes. After calling for help, assess the situation to decide what you should do and in which order.

**Find out if the person is conscious. Tap the person on the shoulder to see if there is a response. Ask, "Are you OK?" If there is no response, the person is unconscious. Call or send for medical help.**

---

If opening the airway restores breathing, place the victim in a recovery position. Continue to monitor the person's breathing until help arrives.

---

Always use a breathing barrier when performing rescue breathing.

---

An easy way to recall the order of treatment in a life-threatening emergency is A-B-C-D: **A**irway, **B**reathing, **C**irculation, and **D**efibrillation.

**A is for airway.** The airway is the passage that allows air entering the mouth or nose to reach the lungs. Always protect the airway of any accident victim. If the person begins to vomit, turn the victim onto the side so that the vomit comes out of the mouth and is not aspirated (inhaled) into the lungs.

If a victim is unconscious, carefully place the person on their back, protecting the head and neck if you must roll the person over. Then, open the airway by pressing (or tilting) on the forehead with one hand and lifting the chin with the other to tilt back the head. This action will keep the tongue from blocking the person's airway.



**B is for breathing.** After opening the victim's airway, check to see if the person can breathe normally. Place your cheek in front of the victim's mouth (about 1 to 2 inches away). Look, listen, and feel for movement and breathing (signals of circulation, or "signs of life") for no more than 10 seconds. If the person is breathing effectively, you will feel and hear the airflow on your cheek and see and feel the chest rising and falling at regular intervals. *If there is no breathing or movement; give two rescue breaths, then begin cardiopulmonary resuscitation.*

Once you have opened the airway, check for movement and breathing for no more than 10 seconds. If the person still is not breathing, give two rescue breaths.

**Step 1**—Place a CPR breathing barrier over the victim's mouth. That may protect both of you from orally transmitted diseases.

**Step 2**—Give two rescue breaths. While maintaining the head-tilt, pinch the nostrils, seal your mouth over the victim's mouth and blow into it to fill the person's lungs. (For an infant, seal your mouth over both the mouth and nose, then breathe gently.) Each breath should last about 1 second. Watch to see if the chest clearly rises. Remove your mouth and then give another rescue breath.

**Step 3**—**For a child or an infant**, after two rescue breaths, check for a pulse for no more than 10 seconds. If there is still no breathing, begin rescue breathing (1 breath about every 3 seconds) and recheck for breathing and pulse every 2 minutes as long as there is a pulse but no breathing. **For an adult**, after two rescue breaths, begin CPR immediately if the victim does not resume breathing.



**C is for circulation.** Signals of circulation mean that the heart is still beating and circulating blood through the body. Normal breathing and movement are signals of life and that there is a heartbeat. In the case of young children (under age 12) and infants, feeling for a pulse for no more than 10 seconds can also be performed. *If there are no signals that the heart is beating, begin CPR immediately.*

Accidents or medical conditions that cause a person to stop breathing can also stop the heart. If the heart is not pumping and circulating blood through the body, the victim will not be breathing, moving, or making normal sounds. If you have delivered two rescue breaths and the victim does not begin to breathe, you should perform cardiopulmonary resuscitation, or CPR, immediately.

If the victim revives, put the person in a recovery position and treat for shock. Monitor the person to make sure breathing does not stop again.

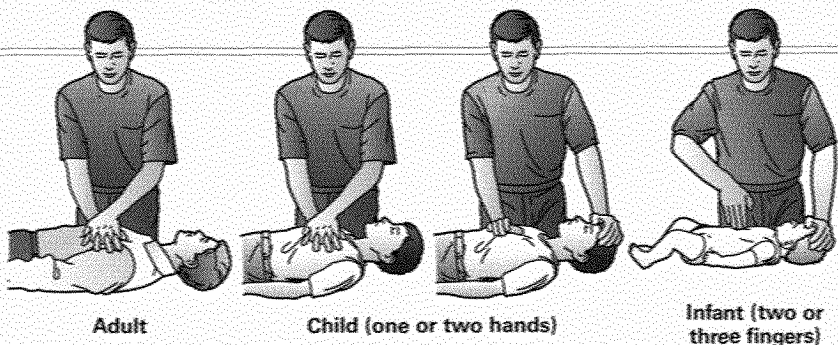

While the techniques for CPR are different for adults, children, and infants, the cycle of 30 chest compressions followed by two rescue breaths applies to everyone. To receive full and proper CPR training, contact your American Red Cross chapter or the American Heart Association. See the resources section in the back for more information.

Learning CPR requires careful instruction from a certified teacher. Perhaps you can practice CPR at Scout meetings. The American Red Cross and American Heart Association offer classes, too. Your Scout leaders can help you find training to learn this lifesaving skill.

**D is for defibrillation.** The heart is made up of many muscle fibers that usually contract and relax in unison to pump blood. During a heart attack, those muscle fibers do not work together. A heart attack can lead to what is known as "cardiac arrest." Another cause of cardiac arrest is an abnormal electrical heart rhythm, most commonly known as ventricular fibrillation.

A machine called a *defibrillator* can send an electrical shock through the heart to momentarily stop all electrical activity. This pause gives the heart enough time to try to restore an effective heartbeat (rhythm). A person whose heart has stopped functioning can be treated with this special device, if one is available. Ideally, this should happen within several minutes of the victim's collapse.

Most ambulances, hospitals, and emergency care facilities are equipped with defibrillators for use by trained medical personnel. Because a defibrillator must be used quickly (within several minutes) to save a person's life, a new type of defibrillator called an *automated external defibrillator (AED)* has been developed. Many first responders such as police officers and firefighters carry and are trained in the use of AEDs.

An AED is computerized. It can check a person's heart rhythm and recognize a rhythm that requires a shock. It can also advise the rescuer when a shock is needed.

AEDs are very accurate and easy to use. With only a few hours of training, you can learn how to operate an AED safely and effectively.

Many public places such as airports and shopping malls now have installed AEDs in clearly marked, designated areas much the same way that fire extinguishers are made readily available for access in an emergency.

## Recovery Position

Place a victim who is unconscious but who is breathing normally in a recovery position. Extend the person's lower arm in line with their body; support the head and neck as you grasp the victim's hip and shoulder, and roll the victim toward you so that the person is lying on the side. This will prevent the person from choking on saliva, blood (from a bitten tongue), or vomit, and will help keep the airway open. Continue to monitor the person's breathing until medical help arrives.

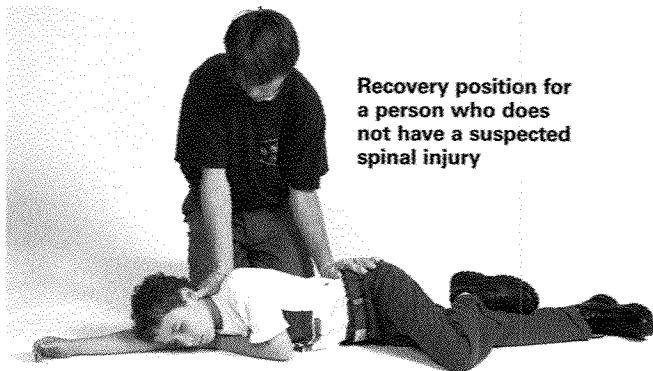

**Recovery position for a person who does not have a suspected spinal injury**

**Recovery position for a person who may have a spinal injury**

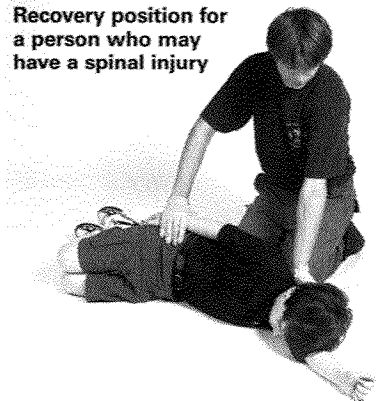

---

You may need to turn a person who has been in a recovery position for 30 minutes or longer to the opposite side to stimulate circulation. However, do not move a person with suspected spinal injury unless it is absolutely necessary.

---

### Bathroom Injuries

In the case of an electrical injury in the bathroom, be especially careful. It is best to throw the main disconnect switch and call 911. There are many grounded objects in a bathroom. The floor is often wet, and it might be difficult to get the victim away from the wire in the small, enclosed space of a typical bathroom.



If the fire can be safely put out, tell an adult to use a proper chemical fire extinguisher.

### Electrical Fire

Electrical fires are different from other fires. Because water conducts electricity, you should never throw water on an electrical fire. Here is what Southern California Edison suggests you do in the event of electrical fire.

- Never use water on an electrical fire.
- Turn off the main power to the house.
- If the fire cannot be safely put out, leave the house immediately and take everyone with you.
- Call 911 from the nearest phone once you and your family are safely away from your home.

## Electrical Storm

The draw of an open wilderness is powerful, but so are lightning strikes that are possible during an electrical storm. If caught in the outdoors and there is no safe shelter nearby, avoid open fields; the tops of hills, ridges, and mountains; bodies of water; and the bases of tall, isolated trees and other tall objects, such as flagpoles. If you are in a forest, stay near a lower stand of trees. Avoid wet items, such as ropes, and metal objects, such as fences and poles. Be aware that tents offer *no* protection from lightning.

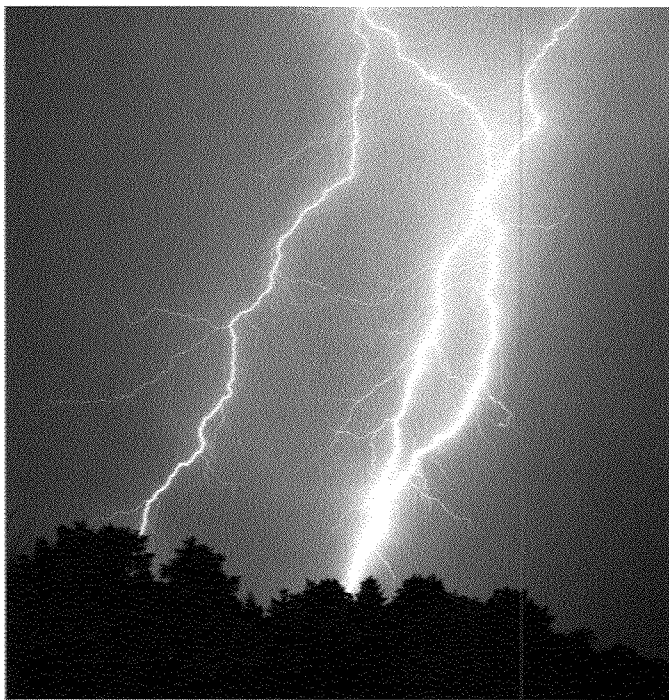

The best thing to do when a storm approaches is to seek shelter in a safe building or vehicle. A safe building is one that is fully enclosed with a roof, walls, and floor and has plumbing or wiring. A safe vehicle is one that is fully enclosed with a metal top.

# Electricity Resources

## Scouting Literature

*Deck of First Aid; Chemistry, Electronics, Energy, Engineering, First Aid, Home Repairs, Inventing, Lifesaving, Nuclear Science, and Safety* merit badge pamphlets

With your parent's permission, visit the Boy Scouts of America's official retail website, [www.scoutshop.org](http://www.scoutshop.org), for a complete listing of all merit badge pamphlets and other helpful Scouting materials and supplies.

## Books

- Asimov, Isaac. *The Kite That Won the Revolution*. Houghton Mifflin Company, 2000.
- Bartholomew, Alan. *Electric Gadgets and Gizmos*. Kids Can Press, 1998.
- Billings, Charlene W. *Superconductivity: From Discovery to Breakthrough*. Cobblehill Books; Dutton, 1991.
- De Pinna, Simon. *Electricity Science Projects*. Raintree Steck Vaughn, 1998.
- DiSpezio, Michael Anthony. *Awesome Experiments in Electricity and Magnetism*. Sterling, 2006.
- Dixon, Malcolm, and Karen Smith. *Electricity*. Evans Brothers, 2005.
- Epstein, Sam and Beryl. *The First Book of Electricity*, rev. ed. Franklin Watts, 1977.
- Flaherty, Michael. *Electricity and Batteries* (Science Factory). Copper Beach Books, 2008.
- Gibilisco, Stan. *Teach Yourself Electricity and Electronics*. McGraw-Hill, 2011.
- Good, Keith. *Zap It! Exciting Electricity Activities*. Lerner Publications Co., 2003.
- Matt, Stephen R. *Electricity and Basic Electronics*. The Goodheart-Willcox Co. Inc., 2012.
- Meïani, Antonella. *Magnetism: Experimenting With Science*. Lerner Publications Co., 2003.
- Morrison, Ralph. *Electricity: A Self-Teaching Guide*. John Wiley, 2003.
- Parker, Steve. *Electricity and Magnetism*. Gareth Stevens Publishing, 2007.
- . *Eyewitness: Electricity*. DK Publishing, 2005.
- Parsons, Alexandra. *Make it Work! Electricity*. World Book Inc., 1997.
- Riley, Peter D. *Electricity* (Straightforward Science). Franklin Watts, 1999.
- Royston, Angela. *Using Electricity* (My World of Science). Heinemann, 2008.



Wood, Robert W. *Electricity and Magnetism FUNDamentals: FUNtastic Science Activities for Kids*. Chelsea House, 1998.

———. *Physics for Kids: 49 Easy Experiments With Electricity and Magnetism*. TAB Books, 1990.

## Organizations and Websites

### Boston Museum of Science

Telephone: 617-723-2500  
Theater of Electricity website:  
<http://www.mos.org/live-presentations/lightning>

### Energy Information Administration

1000 Independence Ave. SW  
Washington, DC 20585  
Website: <http://www.eia.gov>

### Energy Kids Page

Website: <http://www.eia.gov/kids>

### Home Energy Saver

Website: <http://hes.lbl.gov>

### HowStuffWorks.com

c/o Convex Group Inc.  
One Capital City Plaza  
3350 Peachtree Road NE, Suite 1500  
Atlanta, GA 30326-1425  
Website: <http://www.howstuffworks.com>

### Institute of Electrical and Electronics Engineers

445 Hoes Lane  
Piscataway, NJ 08854-4141  
Telephone: 732-981-0060  
Website: <http://www.ieee.org>

### National Energy Education Development Project

8408 Kao Circle  
Manassas, VA 20110  
Telephone: 703-257-1117  
Website: <http://www.need.org>

### North American Electric Reliability Corporation

1325 G St. NW, Suite 600  
Washington, DC 20005-3801  
Telephone: 202-400-3000  
Website: <http://www.nerc.com>

### Safe Electricity.org

Electric Universe  
Website: <http://eec.electricuniverse.com>

### U.S. Department of Energy

1000 Independence Ave. SW  
Washington, DC 20585  
Telephone: 202-586-5000  
Website: <http://energy.gov>

## Acknowledgments

The Boy Scouts of America is grateful to the men and women serving on the National Merit Badge Subcommittee for the improvements made in updating this pamphlet.

## Photo and Illustration Credits

The Franklin Institute Science Museum, courtesy—page 11 (*lightning rod*)  
Shutterstock.com—cover (*light bulb*, ©Bizroug; *digital meter*, ©Pi-Lens; *power lines and lightning*, ©gui jun peng; *danger sign*, ©Allen Graham - PDImages); pages 4 (©ALPA PROD), 6 (*lightning*, ©loflo69), 8 (*electrical discharge*, ©anigoweb), 9 (*feather*, ©mexrix), 13 (*power lines*, ©Shebeko), 18 (*magnetic force*, ©MilanB), 23 (*car battery*, ©Vereshchagin Dmitry), 24 (©topten22photo), 25 (*bird on a wire*, ©sundayhill), 27 (*voltmeter*, ©auremar), 28 (*residential power lines*, ©Civdis), 38 (*fuses*, ©imagedb.com), 44 (*blow dryer*, ©pukach), and 48 (*meter reading*, ©Pi-Lens)

Wikipedia.org, courtesy—page 14  
(*Hauksbee demonstrating electrostatic generator*)

All other photos and illustrations not mentioned above are the property of or are protected by the Boy Scouts of America.

Dan Bryant—pages 18 (*electromagnet*), 19 (*6-volt battery*), and 34–35 (*steps for making a motor*)

John McDearmon—all illustrations on pages 7, 12, 14, 16–17, 19, 21–23, 41, and 56–58

Brian Payne—pages 37 (*steps for making a rheostat*), 39 (*Scout looking at breaker box*), 40, 42, 43 (*Scouts inspecting light fixture*), 46 (*Scouts*), 48 (*Scout reading electric meter*), 50, 52, 55, and 60



The Boy Scouts of America is grateful to the Components, Packaging, and Manufacturing Technology Society of the Institute of Electrical and Electronics Engineers, and to former Scoutmaster and six-time National Scout Jamboree staff member Ralph W. Russell II of the IEEE Precollege Education Coordinating Committee for lending their time and expertise in the 2004 edition of the *Electricity* merit badge pamphlet.

The BSA also wishes to thank the members of Mr. Russell's peer review committee.

- Scouter Michael N. Geselowitz, Ph.D., director of the IEEE History Center, who has served as a Cubmaster, den leader,

pack committee member, troop committee member, and member of his council's Jewish Committee on Scouting

- Scouter Al Mouton, president of AGM Systems
- Lee Reed Sr., safety specialist for Dominion Resources Services
- Rick Tavan, retired vice president of engineering of TIBCO Software, and Electricity merit badge counselor
- Dan Ward, principal engineer for Dominion Virginia Power
- Paul Wesling, vice president of publications for IEEE's CPMT Society, Eagle Scout, Scoutmaster, Venture crew leader, and recipient of the BSA's Silver Beaver and Heroism awards

## MERIT BADGE LIBRARY

Though intended as an aid to youth in Scouts BSA, and qualified Venturers and Sea Scouts in meeting merit badge requirements, these pamphlets are of general interest and are made available by many schools and public libraries. The latest revision date of each pamphlet might not correspond with the copyright date shown below, because this list is corrected only once a year, in January. Any number of merit badge pamphlets may be revised throughout the year; others are simply reprinted until a revision becomes necessary.

If a Scout has already started working on a merit badge when a new edition for that pamphlet is introduced, *they may continue to use the same merit badge pamphlet to earn the badge and fulfill the requirements therein.* In other words, the Scout need not start over again with the new pamphlet and possibly revised requirements.

Merit Badge Pamphlet	Year	Merit Badge Pamphlet	Year	Merit Badge Pamphlet	Year
American Business	2013	Family Life	2016	Plant Science	2018
American Cultures	2013	Farm Mechanics	2017	Plumbing	2012
American Heritage	2013	Fingerprinting	2014	Pottery	2008
American Labor	2018	Fire Safety	2016	Programming	2013
Animal Science	2014	First Aid	2015	Public Health	2017
Animation	2015	Fish and Wildlife		Public Speaking	2013
Archaeology	2017	Management	2014	Pulp and Paper	2013
Archery	2015	Fishing	2013	Radio	2017
Architecture and Landscape Architecture	2014	Fly-Fishing	2014	Railroading	2015
Art	2013	Forestry	2015	Reading	2013
Astronomy	2016	Game Design	2013	Reptile and Amphibian Study	2018
Athletics	2016	Gardening	2013	Rifle Shooting	2012
Automotive Maintenance	2017	Genealogy	2013	Robotics	2016
Aviation	2014	Geocaching	2016	Rowing	2014
Backpacking	2016	Geology	2016	Safety	2016
Basketry	2017	Golf	2012	Salesmanship	2013
Bird Study	2017	Graphic Arts	2013	Scholarship	2014
Bugling (see Music)		Hiking	2016	Scouting Heritage	2017
Camping	2018	Home Repairs	2012	Scuba Diving	2009
Canoeing	2014	Horsemanship	2013	Sculpture	2014
Chemistry	2018	Indian Lore	2008	Search and Rescue	2018
Chess	2016	Insect Study	2018	Shotgun Shooting	2013
Citizenship in the Community	2015	Inventing	2016	Signs, Signals, and Codes	2015
Citizenship in the Nation	2015	Journalism	2017	Skating	2015
Citizenship in the World	2015	Kayaking	2016	Small-Boat Sailing	2016
Climbing	2011	Landscape Architecture (see Architecture)		Snow Sports	2017
Coin Collecting	2017	Law	2011	Soil and Water Conservation	2016
Collections	2013	Leatherwork	2017	Space Exploration	2016
Communication	2013	Lifesaving	2017	Sports	2012
Composite Materials	2012	Mammal Study	2014	Stamp Collecting	2013
Cooking	2014	Medicine	2012	Surveying	2004
Crime Prevention	2012	Metalwork	2012	Sustainability	2013
Cycling	2017	Mining in Society	2014	Swimming	2014
Dentistry	2016	Model Design and Building	2010	Textile	2014
Digital Technology	2014	Motorboating	2015	Theater	2014
Disabilities Awareness	2016	Moviemaking	2013	Traffic Safety	2016
Dog Care	2016	Music and Bugling	2013	Truck Transportation	2013
Drafting	2013	Nature	2014	Veterinary Medicine	2015
Electricity	2013	Nuclear Science	2017	Water Sports	2015
Electronics	2014	Oceanography	2012	Weather	2013
Emergency Preparedness	2015	Orienteering	2016	Welding	2016
Energy	2014	Painting	2016	Whitewater	2005
Engineering	2016	Personal Fitness	2016	Wilderness Survival	2012
Entrepreneurship	2013	Personal Management	2015	Wood Carving	2016
Environmental Science	2015	Pets	2013	Woodwork	2011
Exploration	2016	Photography	2016		
		Pioneering	2017		

## BOY SCOUTS OF AMERICA • SUPPLY GROUP

**NATIONAL DISTRIBUTION CENTER**  
2109 Westinghouse Boulevard  
P.O. Box 7143  
Charlotte, NC 28241-7143

To place an order,  
call customer service  
toll-free 800-323-0736  
or go to  
[www.scoutshop.org](http://www.scoutshop.org)



EAGLE SCOUT



THE SUMMIT



FLORIDA SEA BASE

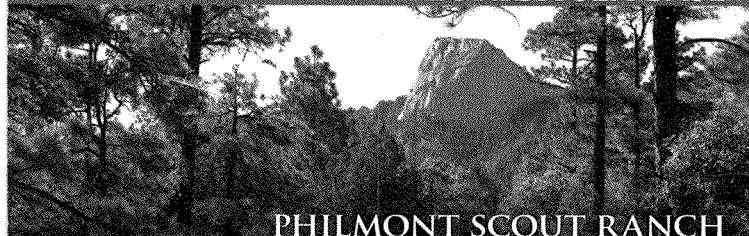

PHILMONT SCOUT RANCH

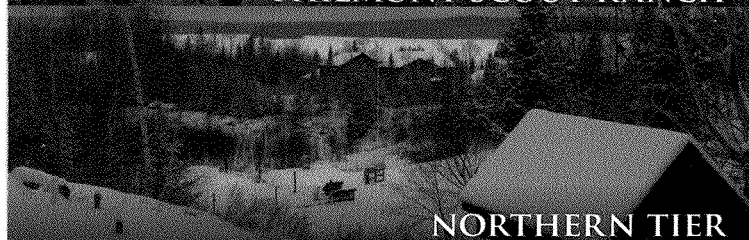

NORTHERN TIER

THE SUPPLY GROUP IS  
READY TO BE A PART  
ON YOUR TRAIL TO  
EAGLE THROUGH HIGH  
ADVENTURE. THE  
ADVENTURE IS YOURS  
AND WE ARE READY  
WITH THE GEAR YOU  
WILL NEED. YOU CAN  
DEPEND ON THE LATEST  
IN LIGHTWEIGHT,  
DURABLE, QUALITY  
GEAR THAT WILL  
MEET AND SURPASS  
YOUR TOUGHEST  
REQUIREMENTS.



WWW.SCOUTSHOP.ORG

SKU 651605



7 30176 35107  
35886 2019 Print

O N THE ROAD TO  
HIGH ADVENTURE



Certified Sourcing  
www.sfi-program.org  
SFI-C0358