

MERIT BADGE SERIES

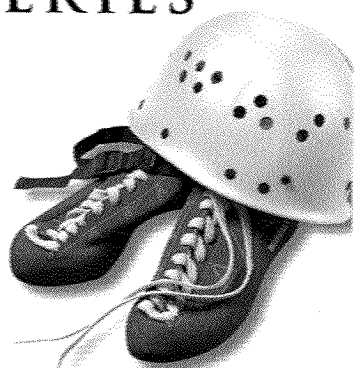

# CLIMBING

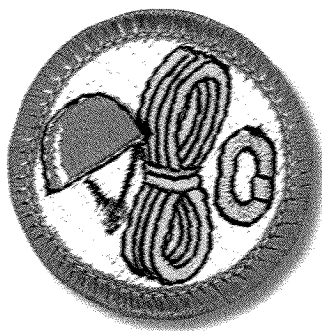
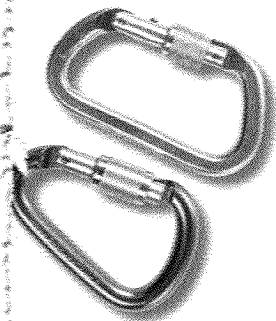
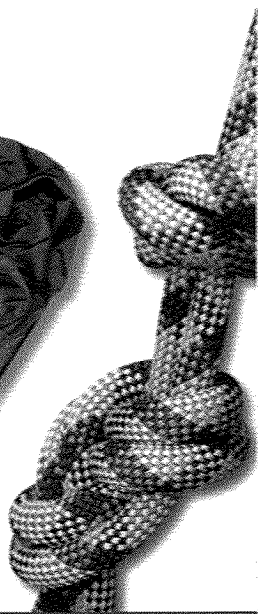
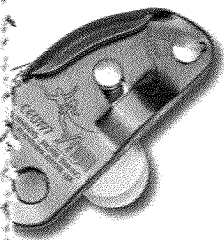

BOY SCOUTS OF AMERICA



## How to Use This Pamphlet

The secret to successfully earning a merit badge is for you to use both the pamphlet and the suggestions of your counselor.

Your counselor can be as important to you as a coach is to an athlete. Use all of the resources your counselor can make available to you. This may be the best chance you will have to learn about this particular subject. Make it count.

If you or your counselor feels that any information in this pamphlet is incorrect, please let us know. Please state your source of information.

Merit badge pamphlets are reprinted annually and requirements updated regularly. Your suggestions for improvement are welcome.

## Who Pays for This Pamphlet?

This merit badge pamphlet is one in a series of more than 100 covering all kinds of hobby and career subjects. It is made available for you to buy as a service of the national and local councils, Boy Scouts of America. The costs of the development, writing, and editing of the merit badge pamphlets are paid for by the Boy Scouts of America in order to bring you the best book at a reasonable price.

Send comments along with a brief statement about yourself to  
Pilots and Program Development, S272

Boy Scouts of America • 1325 West Walnut Hill Lane • Irving, TX 75038

If you prefer, you may send your comments to [merit.badge@Scouting.org](mailto:merit.badge@Scouting.org).



BOY SCOUTS OF AMERICA  
MERIT BADGE SERIES

# CLIMBING

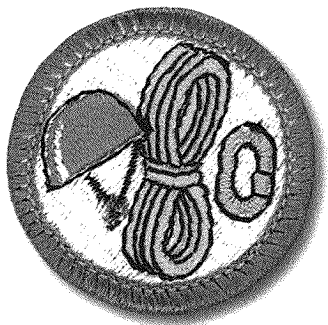

*"Enhancing our youths' competitive edge through merit badges"*



BOY SCOUTS OF AMERICA®

# Note to the Counselor

Young people today seek greater challenges, and climbing and rappelling offer a worthy challenge. The satisfaction of safely climbing a rock face is hard to top. While introduction of the Climbing merit badge in 1997 spurred interest in these activities through the Boy Scouts of America, the proliferation of climbing gyms and facilities has also made climbing and rappelling readily available throughout the United States.

This increased interest has made the BSA more aware of the inherent risks of climbing and rappelling. More accidents occur during unit rappelling than during council-managed climbing or rappelling, and more accidents have occurred during rappelling than climbing. Many climbing and rappelling accidents could be avoided by having qualified instruction from a conscientious adult who has the attention and respect of the youth entrusted to his or her care. Supervision by a caring adult who fully understands and appreciates the responsibility he or she assumes helps assure safety when youth engage in or prepare for climbing or rappelling.

The adult supervisor's relationship with youth should reinforce the importance of following instructions. The adult leader in charge and the climbing instructor share this responsibility. The instructor is responsible for all procedures and for safely conducting the climbing/rappelling activity. The adult supervisor works cooperatively with the climbing instructor and is responsible for all matters outside of the climbing/rappelling activity.



Climb On Safely is the Boy Scouts of America's recommended procedure for organizing BSA unit climbing/rappelling activities at a natural site or a specifically designed facility such as a climbing wall or tower.



*Belay On*, No. 430-500, is the most authoritative guide currently available from the Boy Scouts of America. *Mountaineering: The Freedom of the Hills*, ninth edition, edited by Eric Linxweiler and Mike Maude, is a recommended reference for specific questions not covered in BSA literature. The chapter on transportation in the *Guide to Safe Scouting*, No. 34416, is an appropriate resource for instruction on how to safely get your unit to and from the climbing/rappelling site.

Units that elect to participate in lead climbing and snow and ice climbing are required to receive training from a nationally recognized organization that trains climbing and rappelling instructors. All council and district climbing must comply with the current year's *National Camp Standards*, No. 430-056, and must be top-roped.

Each of the following points plays an important role in the overall Climb On Safely program. Fun and safe climbing/rappelling activities require close compliance of Climb On Safely by the adult supervisor and instructor. These points also apply to bouldering—traversing a few feet above ground level.

- 1. Qualified Supervision.** All climbing and rappelling must be supervised by a mature, conscientious adult at least 21 years of age who understands the risks inherent to these activities. This person knowingly accepts responsibility for the well-being and safety of the youth in his or her care. This adult supervisor is trained in and committed to compliance with the eight points of the Boy Scouts of America's Climb On Safely procedure and responsible for recruiting and verifying the qualifications of the qualified instructors. One adult supervisor is required for every 10 participants with a minimum of two adults for any one group.



The adult supervisor is responsible for ensuring that someone in the group is currently trained in American Red Cross First Aid and CPR (a six-and-one-half-hour course). In addition, Wilderness First Aid (a 16-hour course) is recommended for units going to remote areas. A course of equivalent length and content from another nationally recognized organization can be substituted. A higher level of certification such as emergency medical technician (EMT), licensed practical nurse (LPN), registered nurse (RN), and licensed healthcare practitioner is also acceptable if the person is trained in backcountry medical care. The ARC's Emergency Response, a 4½-hour course that includes CPR, is highly recommended.



- 2. Qualified Instructors.** There must be a minimum of two instructors for all climbing and rappelling activities (up to 12 participants) and one additional instructor for each additional six participants, maintaining a 6-to-1 ratio.

The qualified instructor managing the climbing/rappelling activity must be at least 21 years of age, and be current in his or her training from one or more of the sources listed below or equivalent:

- BSA Level II climbing instructor or climbing director
- BSA Level II COPE instructor or COPE director (artificial structures only)
- Instructors trained by professional organizations or their accredited providers:
  - American Mountain Guides Association (AMGA)
    - Rock instructor
    - Single pitch instructor
    - Climbing wall instructor (artificial structures only)
  - Professional Climbing Instructors Association (PCIA)
    - Base-managed climbing instructor
    - Top-managed climbing instructor
    - Single pitch instructor
    - Climbing wall instructor (artificial structures only)
  - Professional Climbing Guide Institute (PCGI)
    - Top rope guide
    - Single pitch guide
    - Lead guide
    - Multipitch guide
  - Climbing Wall Association (CWA)
    - Climbing wall instructor (artificial structures only)
- Professional climbing guide/instructors who are licensed by the state or accredited according to:
  - AMGA, PCIA, or PCGI for natural rock climbing
  - AMGA, PCIA, CWA, PRCA, or ACCT for artificial structures
- University or college climbing/rappelling instructors who are current in their training (assessment within three years) as rock climbing instructors (or climbing wall instructors for artificial structures only)

- 3. Physical Fitness.** Require evidence of fitness for the climbing/rappelling activity with a current BSA Annual Health and Medical Record, No. 680-001. The adult supervisor should adapt all supervision, discipline, and precautions to anticipate any potential risks associated with individual health conditions. The adult supervisor should inform the climbing instructor about each participant's medical conditions.
- 4. Safe Area.** All BSA climbing/rappelling activities must be conducted using an established climbing/rappelling site or facility. A qualified climbing instructor should survey the site in advance of the activity to identify and evaluate possible hazards and to determine whether the site is suitable for the age, maturity, and skill level of the participants. The instructor should also verify that the site is sufficient to safely and comfortably accommodate the number of participants in the activity within the available time. An emergency evacuation route must be identified in advance. A separate area should be established for onlookers.

Each participant and staff member in the fall zone of a climbing/rappelling site must wear a UIAA- or CE-approved rock-climbing helmet. Everyone must be belayed or tethered when within 8 feet of an edge where a fall of more than 6 feet could occur.

- 5. Equipment.** The climbing instructor should verify that the proper equipment is available for the size and ability level of participants. Helmets, rope, and climbing hardware must meet appropriate requirements as outlined in Belay On. All equipment must be acquired new and/or furnished by the instructor and retired according to the manufacturer's recommendations.

When using a climbing gym, the climbing facility's procedures apply.

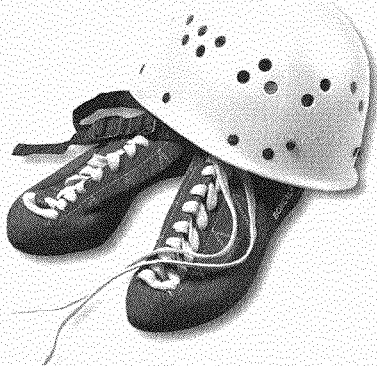

**6. Planning.** When planning, remember the following:

- Share the climbing/rappelling plan and an alternate with parents and the unit committee.
- Secure the necessary permits or written permission for using private or public lands.
- Enlist the help of a qualified climbing instructor.
- Be sure the instructor has a topographic map for the area being used and obtains a current weather report for the area before the group's departure.

It is suggested that at least one of the adult leaders has an electronic means of communication in case of an emergency. Before any activity, an adult leader should develop and share an emergency plan that includes the location of a nearby medical facility and the means of communicating with parents during the activity.

- 7. Environmental Conditions.** The instructor, each adult leader, and each participant assume responsibility for monitoring potentially dangerous environmental conditions that may include loose, crumbly rock; poisonous plants; wildlife; and inclement weather. Use the buddy system to monitor concerns such as dehydration, hypothermia, and an unusually high degree of fear or apprehension. The adult supervisor is responsible for ensuring that the group leaves no trace of its presence at the site.

- 8. Discipline.** Each participant knows, understands, and respects the rules and procedures for safely climbing and rappelling and has been oriented in Climb On Safely and Leave No Trace. All participants should respect and follow all instructions and rules of the climbing instructor. The applicable rules should be presented and learned prior to the outing and should be reviewed for all participants before climbing or rappelling begins. When participants know the reasons for rules and procedures, they are more likely to follow them. The climbing instructor must be strict and fair, showing no favoritism.

---

The concept of challenge by choice applies to all climbing/rappelling activities. No one should be forced or pressured into doing something with which he or she is not comfortable.

---

# Requirements

1. Do the following:
  - a. Explain to your counselor the most likely hazards you may encounter while participating in climbing and rappelling activities and what you should do to anticipate, help prevent, mitigate, and respond to these hazards.
  - b. Show that you know first aid for and how to prevent injuries or illnesses that could occur during climbing activities, including heat and cold reactions, dehydration, stopped breathing, sprains, abrasions, fractures, rope burns, blisters, snakebite, and insect bites or stings.
  - c. Identify the conditions that must exist before performing CPR on a person.
2. Learn the Leave No Trace principles and Outdoor Code, and explain what they mean.
3. Present yourself properly dressed for belaying, climbing, and rappelling (i.e., appropriate clothing, footwear, and a helmet; rappellers can also wear gloves).
4. **Location.** Do the following:
  - a. Explain how the difficulty of climbs is classified, and apply classifications to the rock faces or walls where you will demonstrate your climbing skills.
  - b. Explain the following: top-rope climbing, lead climbing, and bouldering.
  - c. Evaluate the safety of a particular climbing area. Consider weather, visibility, the condition of the climbing surface, and any other environmental hazards.
  - d. Determine how to summon aid to the climbing area in case of an emergency.

5. **Verbal signals.** Explain the importance of using verbal signals during every climb and rappel, and while bouldering. With the help of the merit badge counselor or another Scout, demonstrate the verbal signals used by each of the following:
  - a. Climbers
  - b. Rappellers
  - c. Belayers
  - d. Boulderers and their spotters
6. **Rope.** Do the following:
  - a. Describe the kinds of rope acceptable for use in climbing and rappelling.
  - b. Show how to examine a rope for signs of wear or damage.
  - c. Discuss ways to prevent a rope from being damaged.
  - d. Explain when and how a rope should be retired.
  - e. Properly coil a rope.
7. **Knots.** Demonstrate the ability to tie each of the following knots. Give at least one example of how each knot is used in belaying, climbing, or rappelling.
  - a. Figure eight on a bight
  - b. Figure eight follow-through
  - c. Water knot
  - d. Double fisherman's knot (grapevine knot)
  - e. Safety knot
8. **Harnesses.** Correctly put on a commercially made climbing harness.

9. **Belaying.** Do the following:
  - a. Explain the importance of belaying climbers and rappellers and when it is necessary.
  - b. Belay three different climbers ascending a rock face or climbing wall.
  - c. Belay three different rappellers descending a rock face or climbing wall using a top rope.
10. **Climbing.** Do the following:
  - a. Show the correct way to directly tie into a belay rope.
  - b. Climb at least three different routes on a rock face or climbing wall, demonstrating good technique and using verbal signals with a belayer.
11. **Rappelling.** Do the following:
  - a. Using a carabiner and a rappel device, secure your climbing harness to a rappel rope.
  - b. Tie into a belay rope set up to protect rappellers.
  - c. Rappel down three different rock faces or three rappel routes on a climbing wall. Use verbal signals to communicate with a belayer, and demonstrate good rappelling technique.
12. Demonstrate ways to store rope, hardware, and other gear used for climbing, rappelling, and belaying.



## Contents

Introduction . . . . .	12
Getting Started . . . . .	18
Risk Management and First Aid . . . . .	25
Climbing Smart: The Where and When . . . . .	33
Clothing and Equipment . . . . .	38
Knots . . . . .	50
Harnesses, Anchors, and Belay Systems . . . . .	54
Climbing . . . . .	71
Rappelling . . . . .	85
Climbing Ethics . . . . .	88
Climbing Terminology . . . . .	90
Climbing Resources . . . . .	94

# Introduction

“When man pits himself against the mountain, he taps inner springs of his strength.

He comes to know himself.”

—William O. Douglas, mountain climber and U.S. Supreme Court justice

“On belay?” you shout, and give the rope tied to your seat harness a final inspection.

Far above you, at the top of a steep cliff, your partner answers, “Belay on!”

“Climbing!” you respond and then listen for your partner to reply, “Climb on!”

You reach up and lock your fingers over a nub of rock, then place your foot in a small depression. Leaning out from the cliff as you push up with your foot and leg, you find a higher spot to place your other foot. You jam your free hand into a narrow crack and move your other hand up from the nub to grab a thin ledge.

Another foothold, another hand placement, and you are moving smoothly up the rock. There is nothing but empty air below you and open sky above, and your confidence soars. If you slip, your partner will lock off the belay rope and keep you from falling more than a few feet.

But you won’t fall this time. You’ve been practicing hard, and you feel at home in this vertical world. With grace and skill, you glide from one hold to the next, always looking ahead to plan your next moves.

A cool wind blows against your face and the sun warms your shoulders. You respect the height but do not fear it. As you near the top of the cliff, you are in control, using every bit of your ability and concentration to make your way up the wall of rock.

With a final move, you lift yourself to the top of the cliff as your partner takes in slack from the rope. “Off belay,” you say when you reach a safe place, and wait for the answer: “Belay off.” You have successfully climbed 30, 40, 50 feet or more. You’re a climber, and a huge smile fills your face.

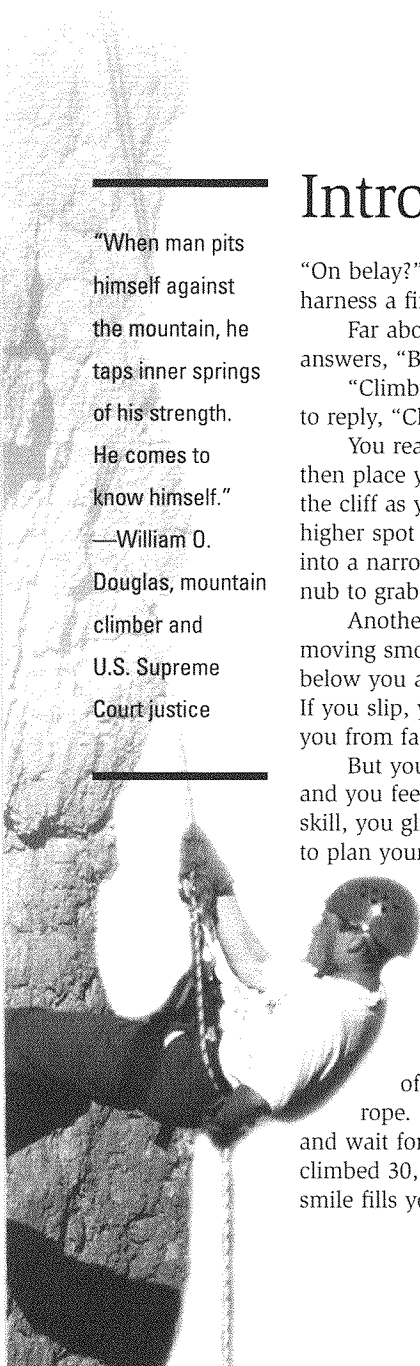

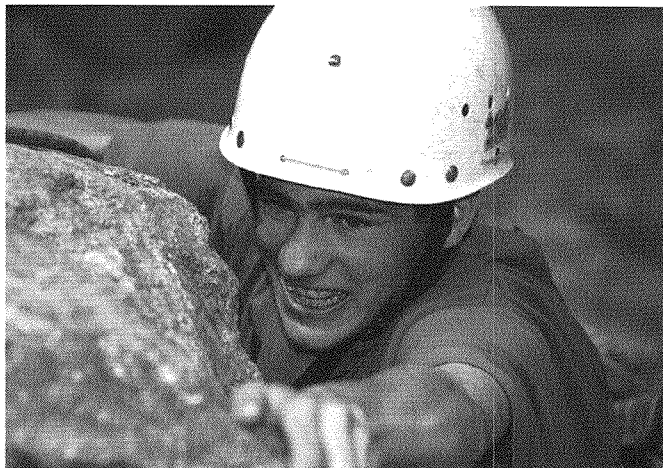

**As you climb, you may develop a deeper respect for the world around you and the important role you can play in protecting climbing areas from harm.**

## The Adventure

Do you love to climb? Do you feel freedom in leaving the flat earth behind? Do high and windy places invite you to come and explore? Climbing allows you to challenge yourself. It is not a sport that requires tremendous muscular strength, though being in good shape will allow you to enjoy it more. What climbing does demand is mental toughness and the willingness to practice hard to master a set of skills.

The adventure of climbing can also give you a new way to have a good time in the outdoors. Climbing really is an activity in which at least half of the fun is getting there. It's great to stand at the top of a climbing route, but even more exciting is what it takes to reach the heights—making good moves and using balance, judgment, and skill to move up steep walls.

Today, you don't have to go to the mountains to learn how to climb. There are plenty of climbing walls throughout the country, and even indoor climbing gyms. If you are in the mountains, your Scouting unit might combine climbing with hiking and camping for terrific outdoor experiences.

As you explore the world of climbing, you can feel the joy of making your way upward toward the open sky. You can test your body and your mind. The skills you learn will form the foundation of a sport you can enjoy for many years to come.

---

“Getting to the summit is optional. Getting back down is mandatory.”

—Ed Viesters,  
Himalayan  
mountaineer

---

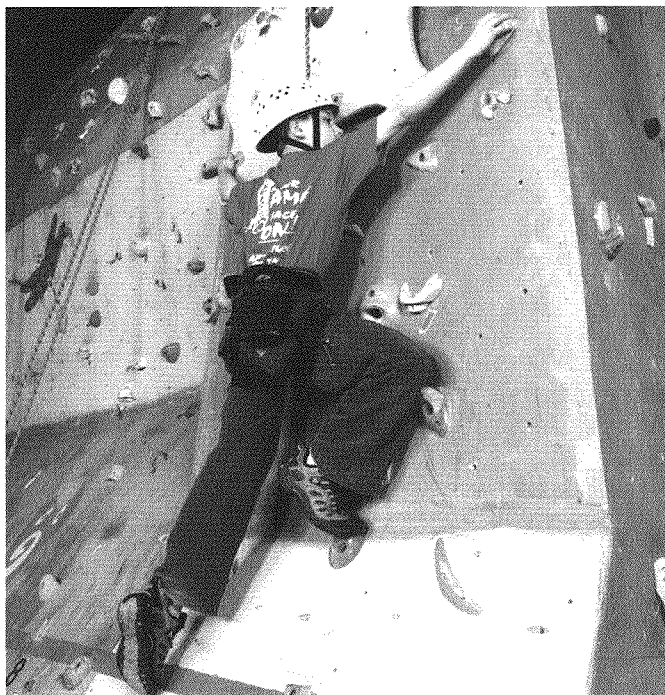

## A Short History of Climbing

Climbing as a modern sport has its beginnings in the 1700s, when people in Europe began trying to ascend the high peaks of the Alps. How they got to the top didn't matter all that much; they simply wanted to stand on the summits and then get down alive.

By the early 20th century, climbers were starting to figure out ways of using ropes to protect each other in case of a fall. They also invented rappelling, a way of descending that

**Early mountaineers, their feet shod in heavy boots, attacked the slopes with little more than hemp ropes (which often broke) and raw determination.**

at first was done using a rope passed under one thigh, across the body, and over the opposite shoulder. This sort of climbing allowed them to practice new ways to move up steep faces and gave them the skill to tackle more difficult routes.

After World War II, plenty of Army surplus stores sold camping and climbing equipment to the public at low prices. Better rope also became available. Many climbers practiced in places like Yosemite Valley in California, and the techniques and equipment of climbing continued to improve.

Special climbing shoes became popular in the 1960s, providing climbers a better chance to use small—even tiny—holds on the rock. Many people also decided to do *free climbing*—relying upon their skill alone to get up a rock face. They no longer let the *belay rope* (safety rope) hold their weight, but used the rope only to stop a fall if they slipped.

The sport of *bouldering* increased in popularity as climbers worked out their moves just a few feet above the ground on boulders. Since they weren't climbing very high, boulderers could—with permission—also enjoy their sport on the sides of stone buildings and anywhere else they could find a few holds for their hands and feet.

By the 1980s, artificial climbing walls began to appear throughout the country, both indoors and out. Many climbers use the walls to practice their technique and to gain endurance before going on trips in real mountains. Climbers today can spend time on any of hundreds of climbing walls throughout the United States or in dozens of climbing gyms. They also can challenge the mountains that might be nearby or set off for the great peaks of the world.

One thing about climbing has never changed: The sky is still the only limit.

**Modern climbers favor lightweight climbing shoes and use climbing ropes and other specifically designed gear for safety.**

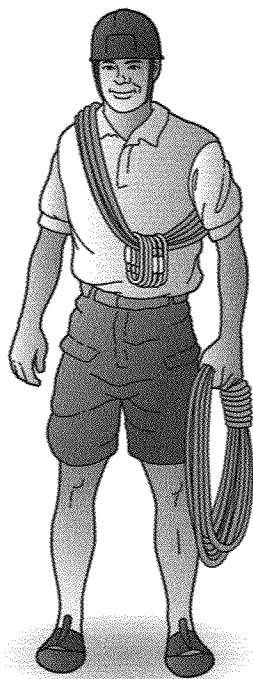

## Climbing Makes an Impression

There's no telling where earning the Climbing merit badge might lead you. Eagle Scout Wally Berg got his first taste of rock climbing under the watchful eyes of instructors at Philmont Scout Ranch in the mountains of northern New Mexico. He was hooked on the joy of climbing and rappelling the cliffs above Cimarroncito Camp.

In the following summers, Wally became a Philmont ranger and trail crew foreman, then added to his mountaineering experience as a full-time instructor of backcountry skills. His expeditions have taken him to the highest mountains on every continent of the globe, including four climbs to the top of Mount Everest. (On the border between Nepal and Tibet, Everest is the world's highest peak.)

Years ago, two other Eagle Scouts—Jim and Lou Whittaker—began going with their troop to the mountains near their home in Seattle, Washington. One of their Scoutmasters was an experienced mountaineer. He taught the Whittaker brothers how to climb, making sure they learned well.

One thing led to another and, in 1963, Jim Whittaker became the first American to climb Mount Everest. Lou Whittaker has also climbed many famous mountains around the world and today runs a guide service that leads people to the snowy top of Mount Rainier in Washington State.

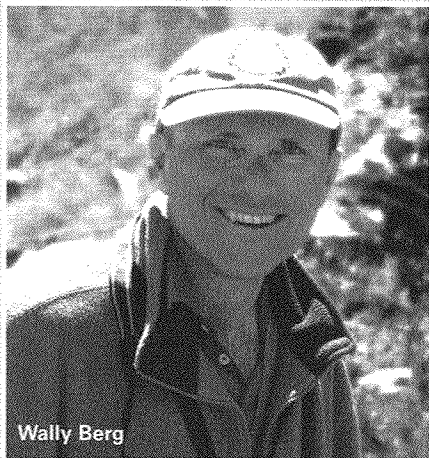

Wally Berg

Your climbing might not take you up Mount Everest any time soon, and you might not become a professional mountain guide. But learning to climb will give you confidence, increase your flexibility, and improve your balance and strength.

Along the way, you are sure to discover what Wally Berg and the Whittaker brothers found out—that climbing can be about as much fun as any adventure that Scouts can have.

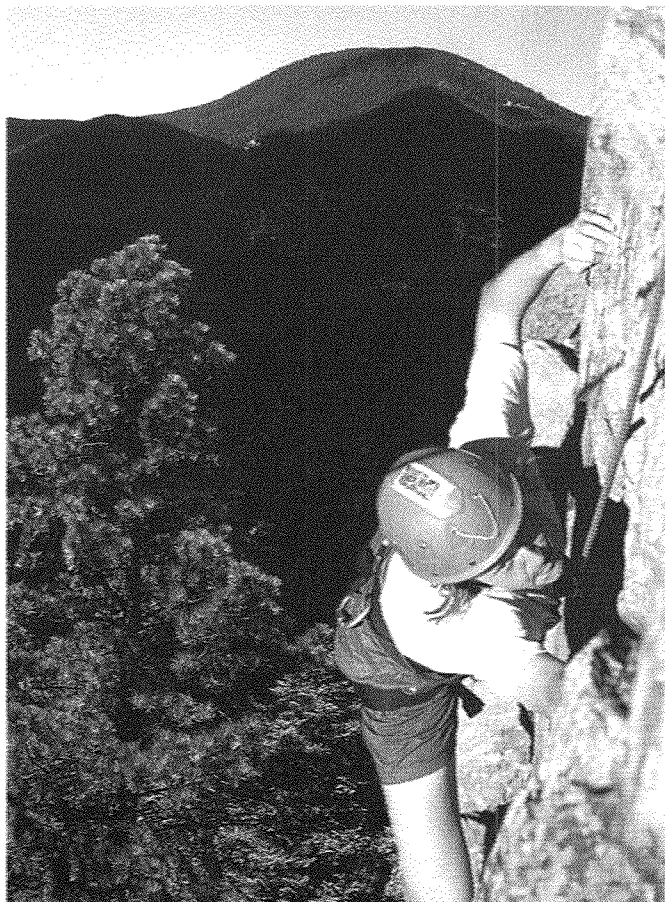

## The Language of Climbing

Some of the climbing terms used in this pamphlet might be new to you. When you find a word or phrase in italics that you don't understand, try to figure out what it means by closely reading the section in which it appears. You will also find many of these terms, from *abseiling to wall*, defined in the terminology chapter near the back of the pamphlet.

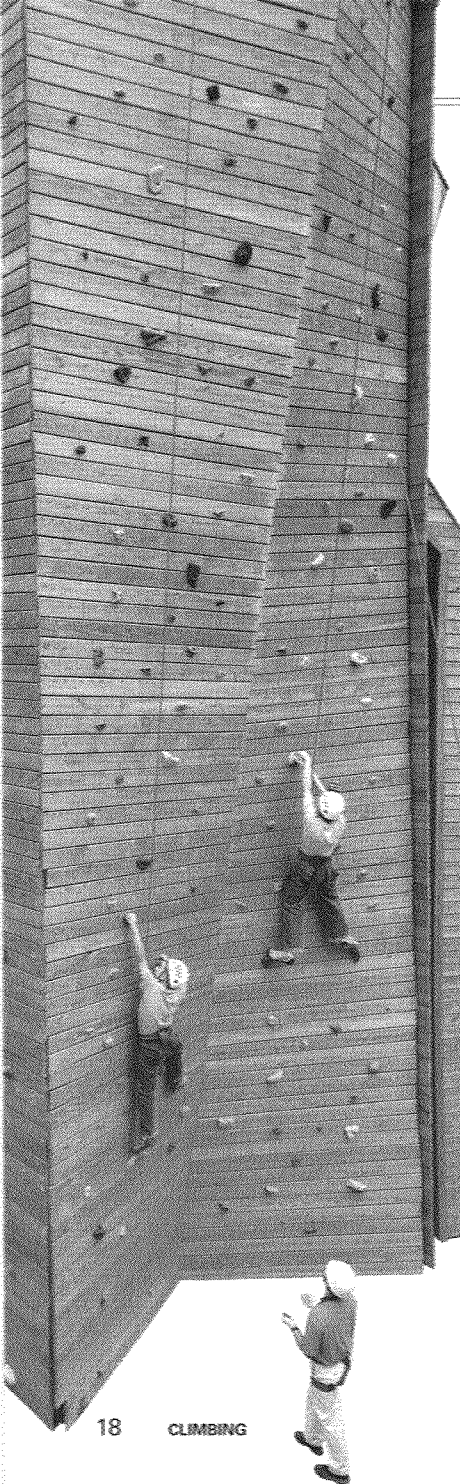

A large, multi-story wooden climbing wall with numerous rock-like holds. Several people are seen climbing at different heights. One person is at the bottom, looking up. The wall is made of horizontal wooden planks.

## Getting Started

This pamphlet describes many ways that you can enjoy climbing and rappelling without taking significant risks. Whether you are a beginner, a world-class mountaineer, or somewhere in between, always make safety the key to all you do.

### Learn From the Experts

Climbing is not a sport you can master by reading a book or by setting out to do it on your own. Trying to learn by trial and error is simply unacceptable on cliffs and other steep terrain or on unsupervised climbing walls and rappel towers. The dangers are far too great. You must have trained instructors who can teach you the right way to climb, belay, and rappel. They also can explain what *not* to do.

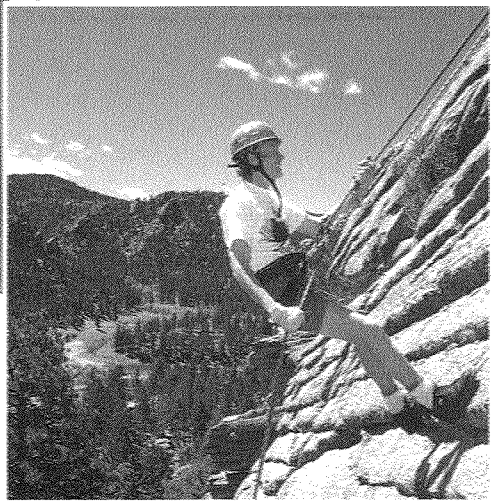





Many Scout camps and some Scout troops and Venturing crews have qualified climbing instructors. Another good way to begin rock climbing might be to sign up for a class through a mountaineering club. Some local colleges in mountainous areas offer instruction in climbing and mountaineering. So do climbing schools, some outing clubs, and most climbing gyms.

## What Is the Sport of Climbing?

The sport of climbing has three elements: climbing, rappelling, and belaying. *Climbing*, of course, is the act of going up, although a good climber can also move sideways and down. Climbers use cracks, ledges, and other features on a natural or artificial face as handholds and footholds. As they climb, they study the rock for the route ahead and figure out a series of moves that will lead them where they want to go.

*Rappel* is a French word meaning "recall." A climber can rappel down steep cliffs by making a controlled slide on a rope. In modern rappelling, the rope is threaded in a special way through a *rappel device* connected to a harness around the waist so that the rappeller can regulate the speed of descent.

A basic fact of climbing and rappelling is that people sometimes fall. They might slip while trying moves that are more difficult than they have done before, or a hand or foot might simply slip off a hold. *Belaying*, a way of protecting climbers from injury, is intended to stop climbers before they can fall very far. Instructors will anchor belayers to trees, boulders, bolts, or other *anchor points* from which the belayer cannot be pulled. A belayer then uses a *belay device* to control a belay rope that is secured to a climber, taking in slack as the climber moves up a wall and holding the rope tightly should the climber fall.

A belayer also can protect a rappeller by letting out a belay rope as the rappeller descends. If the rappeller slips, the belayer can secure the belay rope and stop the fall.

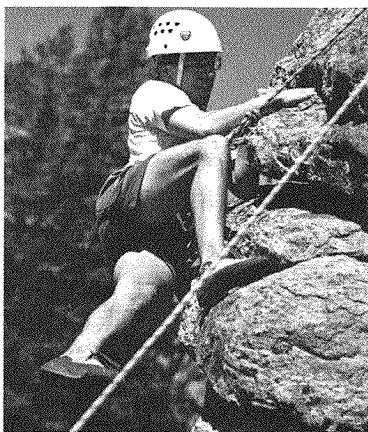

BSA climbing and rappelling guidelines require that a climber or rappeller be protected with a belay rope during all BSA climbing/rappelling activities where the participant's feet are more than shoulder height above ground level.

Anyone who is bouldering—practicing climbing moves closer to the ground—does not need to be tied into a belay rope but should be protected by two or three *spotters* in position, ready to break a person's fall and help prevent injury.

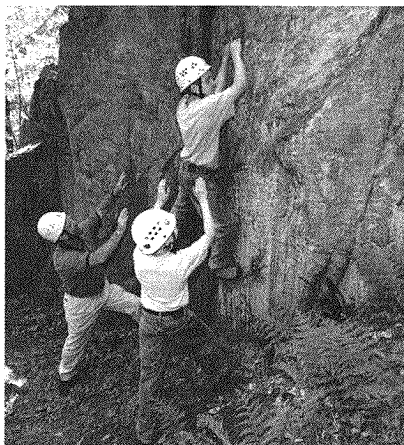

## Top-Rope Climbing and Lead Climbing

In any BSA climbing activities where a participant's feet are more than shoulder height above ground level, that person must be protected with a top-rope belay.

In *top-rope climbing*, climbers are tied to belay ropes that are anchored above them throughout their climbs. Belayers may be managing the ropes from the top of climbing routes or may be at the bottom of the cliff or wall. A belayer stationed on the ground uses a rope that goes up to an anchor at the top of the climb, then back down to the climber. Because of its shape, this kind of top-roping is sometimes called a *slingshot belay*. (See the illustration of a top-rope belay in the chapter titled "Harnesses, Anchors, and Belay Systems.")

In *lead climbing*, climbers are tied to belay ropes extending below them. As they climb, they insert artificial protection such as chocks, cams, nuts, or other hardware into cracks in the rock, then attach the rope with *carabiners* and/or *quickdraws* (two carabiners connected with a short runner). In this way they are able to establish points of protection as they ascend.

The distance a lead climber may fall is determined by how close the climber is to where a point of protection has been placed and by how effectively the belayer handles the rope. **During council and district activities, lead climbing may be practiced only if lead climbers are protected by a top-rope belay.**

## Climbing Classification System

Climbers have developed rating systems for describing the difficulty of different climbs. Guidebooks for popular climbing areas use these systems to help people decide which routes match their skills. In the classification system most frequently applied to climbing in North America, there are five classes.

If you have been on a Scout hike, you already know about Class 1 travel. And, if you have backpacked crosscountry, you may have done some Class 2 work. Traveling through steeper

### **Class 1—Hiking.**

Hands are not needed for balance.

### **Class 2—Simple**

**scrambling.** Hands may be used now and then for balance. A rope is not needed, although one may be carried.

### **Class 3—Scrambling.**

Using the hands and some basic climbing skills. A rope may be used to belay any party members uncomfortable with the exposure.

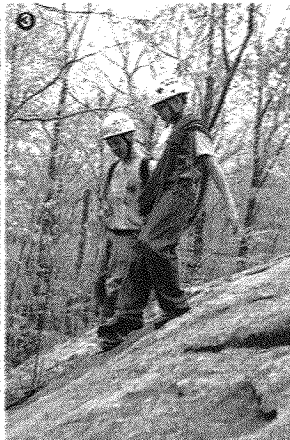
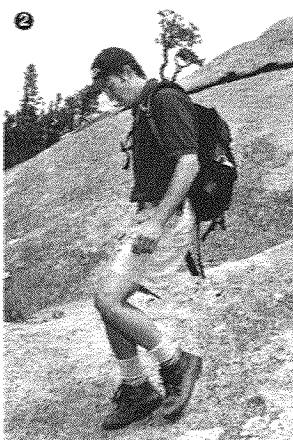

terrain may have introduced you to slopes rugged enough that you must frequently use your hands for balance and be especially careful because of an increased danger of falling; that's Class 3 scrambling and/or slab climbing. Class 4 climbing can involve short, steep sections where the use of a rope is recommended, and unroped falls could result in injury.

Scouts can practice Class 5 skills at an outdoor climbing/rappelling area or indoors at a climbing gym. Class 5 climbers may become good belayers, too, since they often take their turn handling the belay rope that should protect every Class 5 climber.

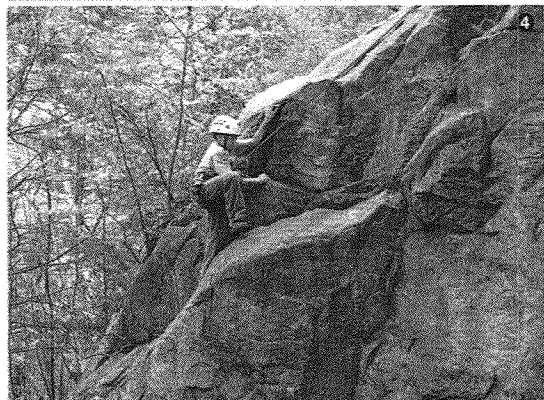

**Class 4—Climbing with a belay.** Climbers should be protected with a belay rope.

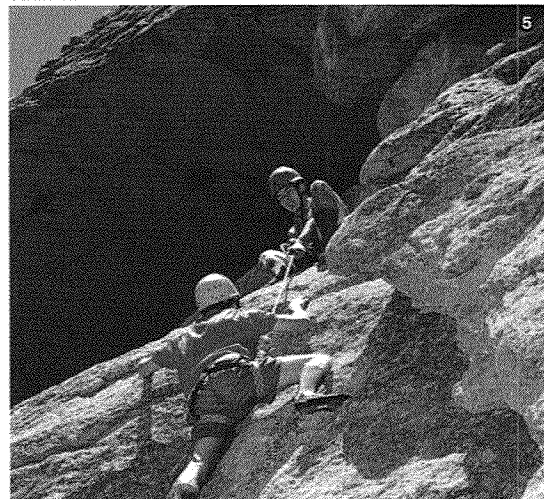

**Class 5—Roped climbing with protection.** Class 5 climbing is divided into categories of difficulty based on the Yosemite Decimal System, which is the North American rating system. They range from 5.1 (very easy) to 5.15 (extremely difficult). Class 5 climbers ascending with their feet more than shoulder-height above the ground must always be protected with a belay rope.





**Using proper belaying techniques helps make managing risk a habit and not an afterthought.**

# Risk Management and First Aid

Climbing and rappelling, when properly done, are as safe as most other Scouting adventure activities. Like most other Scouting activities, there are certain risks to be managed with careful planning, attention to safety issues, and being prepared to respond well should an injury or illness occur. Even short falls can lead to minor bruises or skinned knuckles and knees. Though rare, a longer fall can result in sprains, abrasions, or fractures.

## Responding to Emergencies

Before beginning a climb, your group should work out an emergency response plan that includes information about the location of the nearest telephone and the telephone numbers of the closest hospital, sheriff's department, and rescue unit. In many areas of the country, dialing 911 contacts all three.

## Cardiopulmonary Resuscitation

Cardiopulmonary resuscitation—CPR—is an important first response in the event of a cardiac emergency. It is used only for extreme emergencies—when the person has no pulse, indicating that the heart has stopped beating. CPR includes both chest compressions and rescue breathing (mouth-to-mouth resuscitation).

When climbing at rock sites in the backcountry, you will be away from immediate emergency assistance, and response times for emergency services might be delayed. It is a good idea to be prepared by becoming trained in wilderness first aid. Check with your local American Red Cross, National Safety Council, or American Heart Association for appropriate courses.

---

As a climber, you will follow many of the same risk management guidelines that you would for any Scout hike or camping trip.

---

The Scouts BSA handbooks and *First Aid* merit badge pamphlet explain how to identify the conditions that must exist before performing CPR on a person.

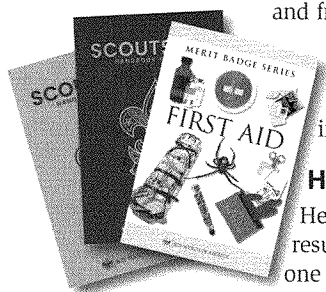

These books also discuss first aid in more detail.

CPR courses are designed to teach rescuers how to recognize life-threatening conditions and respond appropriately. Check with the American Red Cross, the National Safety Council, the American Heart Association, and other similar organizations in your area to find out if they offer CPR and other first-aid training. Every BSA climbing or rappelling activity should include at least one person on-site who is trained and certified in CPR. You need to know CPR before you have to use it.

## First Aid

While climbers prepare by keeping fit and planning ahead, first-aid situations sometimes will arise. Always have a well-equipped first-aid kit at hand, both while climbing and while traveling to and from the site. All climbers should be prepared to take action.

Instructors at climbing and rappelling areas at Scout camps should be trained to respond quickly to emergencies. At indoor climbing gyms, the staff will take the lead in treating injuries and contacting help.

## Heat Reactions

Heat reactions, including heat exhaustion and heatstroke, result when the body cannot keep itself cool enough. If someone feels dizzy, faint, nauseated, or weak; develops a headache or muscle cramps; or looks pale and is sweating heavily, treat for **heat exhaustion**. Have the person lie down in a cool, shady spot with the feet raised. Loosen clothing and cool the person with a damp cloth and fan. Have the victim sip water slowly. Recovery should be rapid. If the condition worsens or does not improve, get medical help.

**Heatstroke** occurs when the body's heat-control system shuts down, causing the victim's temperature to rise to life-threatening levels. The skin may be wet or dry but always will be flushed and hot. The pulse is extremely rapid, and the person will be disoriented or unconscious. Cool the victim immediately through immersion or with cold packs. When the victim is able to drink, give all the water wanted. Treat for shock and seek medical attention immediately.



To prevent the familiar condition called **sunburn**, use a sunscreen with a sun protection factor (SPF) of at least 15 and limit your exposure time. Apply sunscreen liberally before exposure (don't forget your ears and the back of your neck), and reapply often if you are sweating. If your skin begins to redden or if you feel discomfort, seek shade. Treat painful sunburn with damp cloths. Remedies containing aloe vera also might provide some relief. Protect your lips by applying a lip balm with an SPF of at least 15. To protect your eyes, wear sunglasses.

## Cold Reactions

**Hypothermia** occurs when a climber becomes so cold that he can no longer keep warm. As the core temperature drops, vital organs shut down. In extreme cases, death may result. Hypothermia can sneak up on a climber gradually, especially on a chilly, windy day. Since hypothermia impairs the ability to think clearly, the victim may not realize the danger and may not be able to save himself. Prevent hypothermia by staying warm and dry, taking breaks, and eating plenty of energy foods.

A victim who shows early symptoms of hypothermia will feel cold, tired, and irritable. The victim's teeth may chatter, and the person may begin to shiver. As the condition worsens, the victim begins to shiver uncontrollably and gets increasingly confused. In advanced stages, the victim is disoriented, cannot travel, and may collapse; the shivering stops, followed by unconsciousness. Death may soon follow.

Take action to rewarm anyone who shows signs of hypothermia and prevent further heat loss. Move the victim to a shelter and wrap the person in a blanket or sleeping bag (remove wet clothing) until body temperature warms to normal. For additional warmth, keep the head covered. Give the victim hot drinks if available (no caffeine or alcohol) and only if the victim is alert enough to drink.

In severe cases you must actively warm the victim. Get the person under shelter and into a sleeping bag. If possible, zip two sleeping bags together. Crawl into the bag with your companion and strip the clothing from both of you; this effort will help generate body heat. The skin-to-skin contact also will warm the victim and perhaps save a life.

Cold winter weather, especially if it is windy, brings with it the danger of **frostbite**. Essentially, a part of the body becomes frozen. The flesh becomes numb, though sometimes the victim

---

A frightened or anxious victim might breathe too rapidly or too deeply, which can result in hyperventilation. Calmly encourage the person to relax and breathe slowly.

---

Prevention goes hand in hand with mitigation, which means “to lessen in force or intensity” and “to make less severe.” By taking precautions to manage risk and first aid, you can be prepared to anticipate, help prevent, mitigate, and respond to just about any climbing hazard.

## Dehydration

Dehydration, caused by lack of water in the body, can occur in cold or warm weather—anytime a person is sweating profusely and/or not drinking enough liquids. Avoid dehydration by drinking plenty of fluids and eating enough throughout the day to keep your body well-balanced. If you become weary or develop a headache or body aches, or if you become confused, rest in the shade and sip water until the symptoms subside.

Climbers who have severe allergic reactions to wasp, hornet, or bee stings should carry a field treatment kit with them on all outings, and their companions should be familiar with its use.

may not notice. If the freezing continues, the area will stiffen and become grayish-white in color. To treat the victim, *thaw the affected area only if there is no risk of refreezing. Once warmed, keep the affected area warm. Do not rub the area with snow.* In the field, use body heat. Put cold fingers under the armpit and the warm palm of your hand on frostbitten nose, ears, or cheeks. In a shelter, if possible, put cold feet on a companion’s bare belly, or immerse the affected area in lukewarm water—no warmer than 108 degrees. If blisters develop, apply a large sterile dressing. Treat the victim for shock and immediately seek medical attention.

### Other Possible Climbing-Related Injuries

**Rope burns**, or friction burns, can occur when climbers allow rope to slide too quickly through their hands or when any part of the body comes in contact with a fast-moving rope. A rope burn is characterized by raw, red skin and sometimes blistering. The best protection against rope burns is, of course, to wear climbing gloves, but if a burn does occur, clean the area with mild soap and water to help prevent infection.

For typical **stings and bites**, carefully scrape away the stinger with the edge of a knife blade. Don’t try to squeeze it out—that will force more venom into the skin from the sac attached to the stinger. An ice pack might reduce pain and swelling. If you have 0.5 percent hydrocortisone cream, apply it to help soothe insect stings and bites. For severe and prolonged pain, or for any severe reaction, dizziness, or respiratory distress, get medical help.

*Tick bites* are common maladies in the outdoors. If a tick has attached itself, grasp it with tweezers close to the skin and gently pull until it comes loose. Don't squeeze, twist, or jerk the tick, as that might leave its mouthparts in the skin. Wash the wound with soap and water; apply antibiotic ointment. Dispose of the tick and thoroughly wash your hands. (Always avoid direct contact with a tick because disease can be transmitted by finger contact.) If a tick has been embedded more than a day or poses difficulties in removal, see a physician.

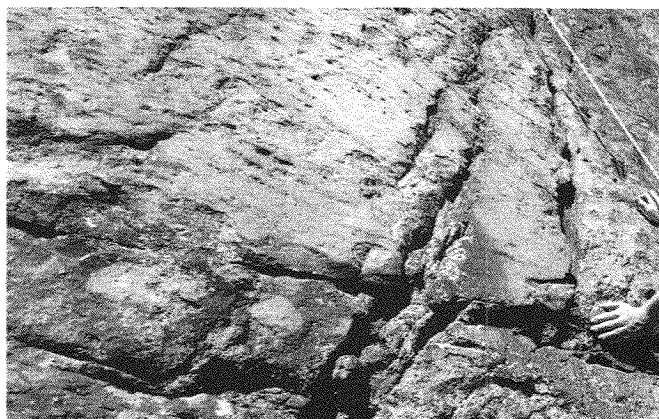

As you climb, look out for snakes—watch where you put your hands.

**Snakebite** is rare and seldom fatal. Snakes generally try to avoid humans and normally strike only when they sense danger. The bite of a nonpoisonous snake requires only ordinary first aid for small wounds—scrubbing with soap and water, then treating with an antiseptic. However, the bite of a poisonous snake can cause sharp, burning pain, swelling, and discoloration. Follow these steps.

1. Seek medical care for the victim as soon as possible.
2. Remove rings and other jewelry that might cause problems should the area around the wound swell.
3. Have the victim lie down and keep still; help the patient stay calm to help slow the spread of the venom. Position the wound area lower than the rest of the body.



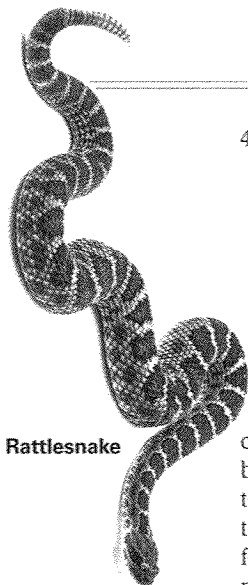

Rattlesnake

4. If medical help will be delayed, put a broad, constructing band (strip of cloth, belt, or neckerchief at least 1 inch wide) around the limb, 2 to 4 inches above the bite (between the heart and the bite), to slow the spread of venom. This is *not* a tourniquet; make the band snug but loose enough to slip a finger under easily. Periodically check for pulse on both sides of the band; do not cut off blood circulation entirely. Do not use a band around fingers, toes, head, neck, or trunk. Splint the area as for a fracture.

For **abrasions** (cuts and scrapes), clean, disinfect, and cover the wound. **Blisters** form when skin is irritated, usually by friction or heat. A **hot spot** signals the beginning of a blister. Stop immediately and protect the tender area by covering the hot spot with a piece of mokeskin or molefoam. If a blister forms, build up several layers of mokeskin or molefoam, as needed, to take off the pressure. Blisters are best left unbroken. Treat a broken blister as you would a minor cut or abrasion.

A **sprain**, caused by a twisting, wrenching, or lifting movement, tears or stretches tissues surrounding a joint. The area will feel tender to the touch, and you will feel sudden pain when you move, so try to keep still. Elevate the area and apply a cold compress for 15 to 20 minutes. For persistent or severe pain, seek medical attention.

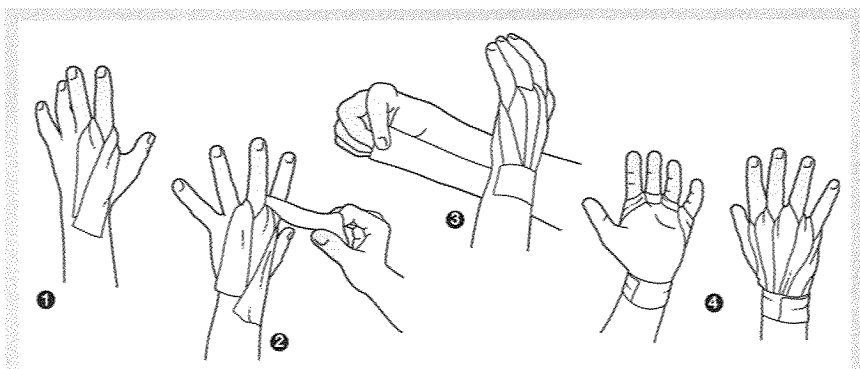

Even climbers with perfect technique can suffer scrapes and cuts. Wrapping the hands with cloth tape (athletic or coach's tape) can give some protection. Your climbing instructor can show you how to tape your fingers and hands. Here, the back of the hand and knuckles are protected, while the palm is mostly left open.

**Fractures**, or broken bones, can be either closed (simple) or open (compound). In a simple fracture, the skin is not punctured. In a compound fracture caused by a climbing incident, there is a wound through the skin where the bone is broken. If you suspect a fracture, do not try to move the injured area to test for pain. Look for these other signs:

1. Tenderness to the touch over the site of the break. It hurts when you press gently on the skin over the fracture.
2. Swelling or bluish color at the fracture site.
3. An unusual or abnormal shape, position, or movement of the bone or joint.
4. A grating sound or feeling.
5. An inability to move the injured limb.
6. The victim may have heard or felt a bone snap.

A compound fracture will show the signs above in addition to an open wound.

## Altitude Sickness, or Acute Mountain Sickness

If you are climbing in a mountainous area and aren't used to the high elevation, the thin air, which contains less oxygen than areas closer to sea level, may leave you short of breath and tired. You might develop a headache and suffer from nausea. As a quick fix for AMS, or acute mountain sickness, immediately descend to a lower elevation. Give your body time to adapt to higher altitudes by ascending gradually. After hiking upward during the day, descend to a lower camp for a good night's rest. For more information about AMS, see the *Fieldbook*.

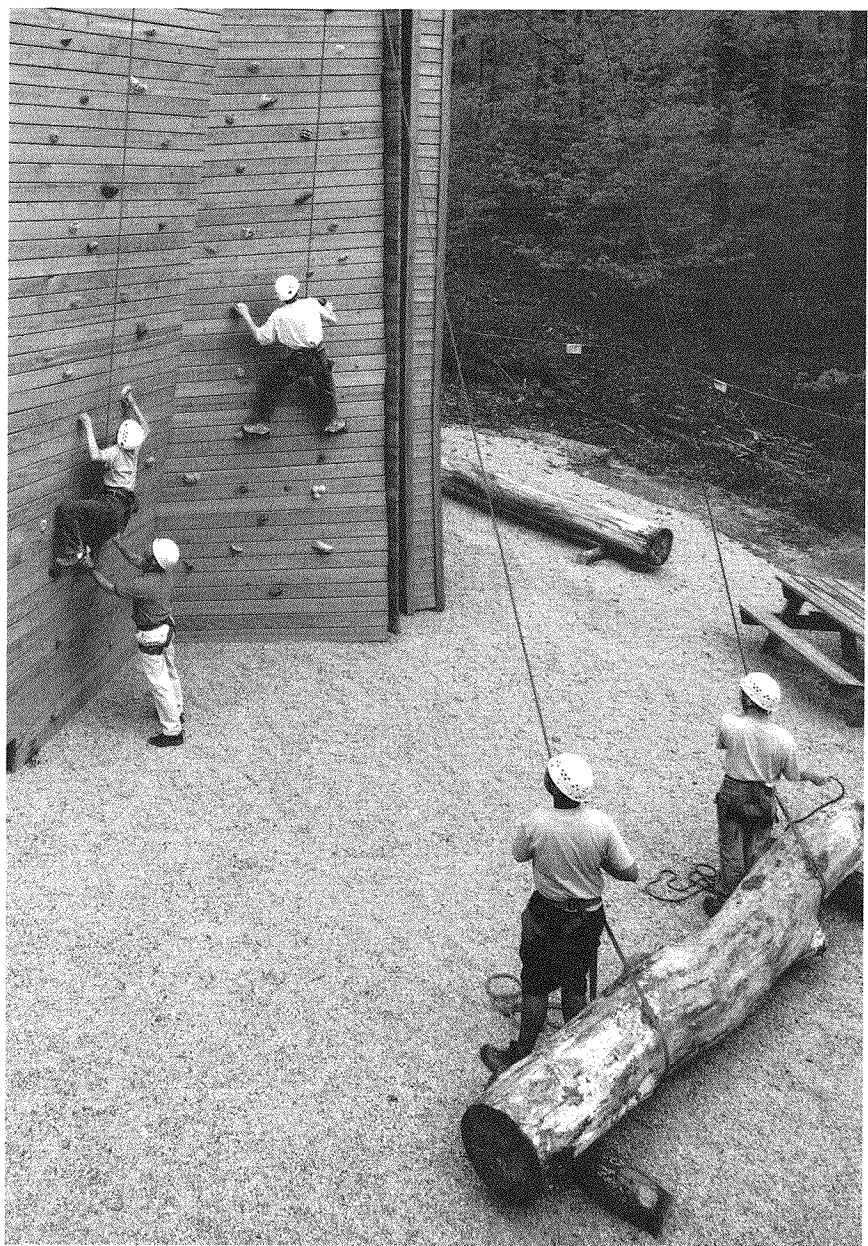

# Climbing Smart: The Where and When

Good training, safety awareness, and common sense will let you enjoy climbing for many years. Taking chances may bring your climbing days to a quick end. Experienced climbers take pride in climbing smart, and so can you.

A big part of climbing smart is knowing when *not* to do it. Don't climb alone. If you fall and are hurt, you will need the help of others to give first aid and contact rescuers. Don't go climbing unless you are with qualified instructors who can belay you and teach you the skills you need. Don't go climbing unless you have the proper equipment.

Before you go climbing, discuss your plans with your Scout leader, parents, or other responsible adults. They may approve of your idea or suggest changes in your plan. Sometimes it might be best to put off climbing and enjoy some other kind of adventure.

Always think about the "what if." You might be tempted during a campout to climb a cliff. But first, ask yourself some "what if" questions. *What if I fall and am injured? What if I can't get down?* "What if" questions can help you climb smart, even if that means not climbing at all.

## Where to Climb and Rappel

At one time, serious climbing was done only in the mountains. Today, however, you can find climbing areas and opportunities just about anywhere throughout the country.

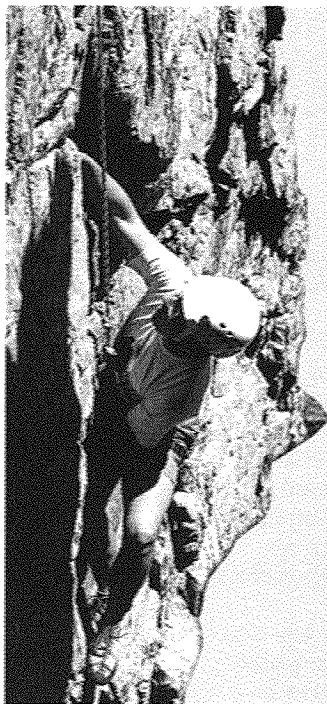

## Safety Pointers for Climbing Smart

- Never climb alone.
- Learn from the experts.
- Use the proper equipment.
- Stay within your abilities.
- Don't hurry.
- Keep your mind on what you are doing. Stay focused.
- Climb no higher than having your feet shoulder-height above the ground unless you are belayed with a rope.
- When climbing lower than the height requiring a belay, have two spotters in position to help protect you from injury if you fall.

### Rock Faces

The handholds and footholds on steep cliffs, mountainsides, and canyon walls have long attracted climbers. Trees, boulders, rock outcroppings, or specialized bolts driven into rock serve as anchor points for belay and rappel ropes. Rock faces offer a wide variety of opportunities, levels of difficulty, and spectacular scenery. Some cliffs have lots of nubs, ledges, and cracks to help climbers on their way. Other rock faces are smoother and more challenging.

Natural climbing areas can be found in many Scout camps, in state and national parks, and on public lands. Other inviting rock faces are on private property. Always get permission from property owners or land managers before setting out on a climb, and follow any guidelines the public agency or private landowner might require.



## Artificial Walls

In recent years, outdoor climbing walls have been built in many of America's city parks and Scout camps. These walls often are constructed from sheets of plywood with handholds bolted in place, or formed from concrete embedded with small rocks that serve as holds for hands and feet. Metal rings set into the tops of the walls provide anchors for belay ropes. The base may be surrounded with a bed of wood chips, gravel, or shredded rubber to help cushion the landing of a climber coming off the wall.

A growing number of schools, climbing clubs, and climbing gyms have indoor walls that challenge climbers of all levels. Handholds of different shapes create climbs of varying difficulty. The handholds can be moved around to provide climbers with fresh routes.

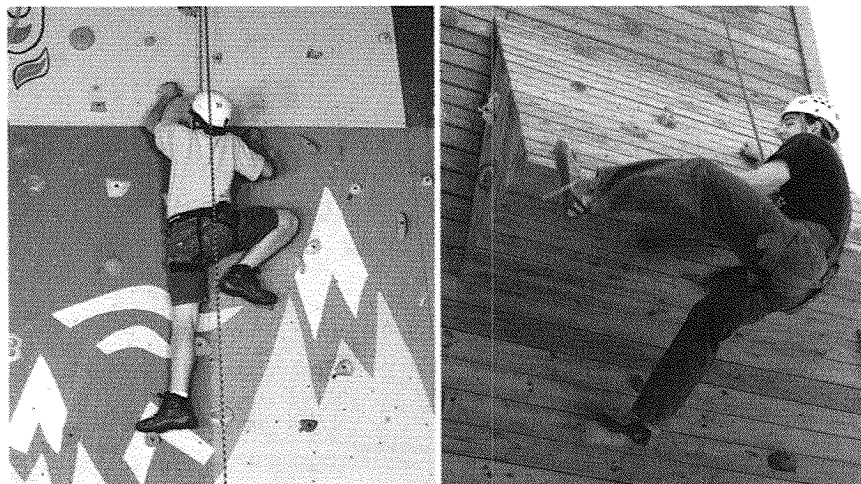

Belay ropes anchored above the walls protect climbers as they practice their moves.

## Checking the Safety of a Climbing Area

The temperature, lighting, and stability of an indoor climbing wall can be controlled as easily as the conditions in any sports gym. However, most climbing areas are outdoors, where conditions can vary. Before beginning, take a few minutes to evaluate the safety of the place you want to climb. Here are some factors to consider.

## Rock

Be alert for storm clouds, which can blossom suddenly. Don't climb when it is stormy or raining.

The kind of rock in an area can make a big difference in climbing safety. In general, hard rock such as granite offers climbers the best surfaces. Sandstone and other softer rock, or rock that is fractured or layered, such as shale, may crumble or slide away under a climber's weight. Even the hardest rock may have pieces that can come loose.

Approach every handhold and foothold carefully; until you have tested a hold and found it to be sound, assume that it will pull out. Look above the climbing area, too, to see what might be waiting to fall. Stay away from faces that are beneath leaning pinnacles or hanging boulders. Listen for the sound of small stones bouncing down the rock—a sign that there is unstable material above.

## Lightning Strikes

If you can hear thunder, you are close enough to the storm to be struck by lightning. Here are some precautions to take.

- Avoid open areas and lightning targets (trees, flagpoles, wire fences).
- Avoid contact with anything metal (carabiners and other metal climbing devices; metal-framed backpacks and tents).
- If you are near a mountaintop, get downhill. If a storm catches you, take shelter in a cave or low spot in an area that is not likely to flood.
- Seek out a steel-framed building or hard-topped motor vehicle (not a convertible) if you can, and avoid touching the metal parts. Avoid water. Avoid using or any contact with electronic devices (GPS receivers, mobile phones).
- If you cannot find shelter, get small. Crouch low with only the soles of your shoes touching the ground, and at least 100 feet from your companions.

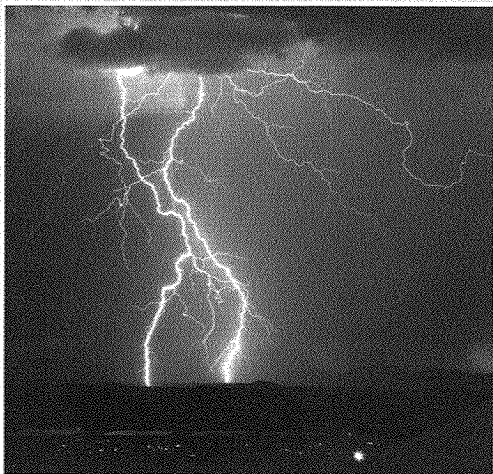

## Weather

Stay off rock faces when it is raining. Water will make climbing surfaces slippery. Wet ropes can be difficult for belayers to hold, and climbing equipment that has become wet or even damp must be dried before you store it. Make sure that at least one adult leader is currently trained in Hazardous Weather training at [my.scouting.org](http://my.scouting.org).

Storms can develop quickly and catch you off guard if you have not been watching the sky. Some rock faces are near ridgetops that may be the targets of lightning, though lightning also can hit locations deep in valleys. Carabiners and other metal climbing hardware can conduct electrical currents from lightning strikes, as can wet rope. At the first signs of bad weather or lightning, stop climbing and retreat to a safe location.

## Safety on Edges

Cliff or rock edges can be hazardous because of the possibility of falling or of knocking stones loose and sending them down toward people below. Anyone standing or working within a body length of the edge of a cliff (6 feet or less) must be tied in to a belay, an anchor, or a safety line. Before climbing or rappelling activities begin, instructors should make sure cliff edges are clean, carefully removing as much loose material as is practical to make the edge usable.



## Clothing and Equipment

For the most part, any clothing that is comfortable, rugged, and suitable for the weather will be fine for climbing. Pants, shorts, and shirts should let you move freely as you stretch to reach handholds and footholds, but not so baggy that folds of cloth can catch on rock outcroppings or tangle in belay or rappel systems.

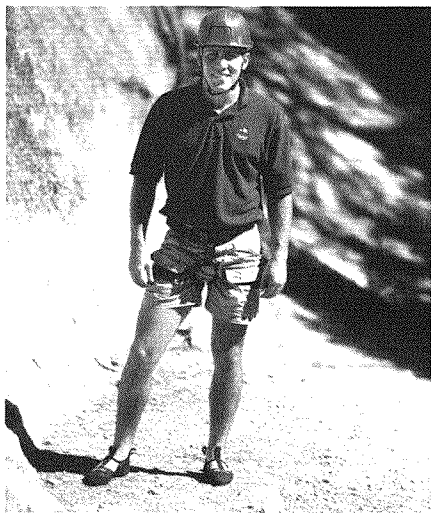

**For climbing, wear clothing that lets you move freely but is not baggy.**

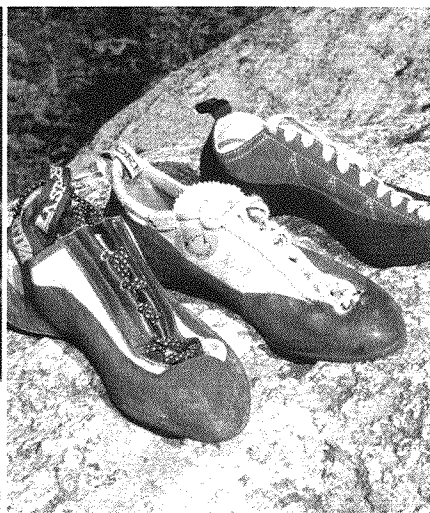

**Climbing shoes**

What you wear on your feet can make a big difference in how well you can climb. Avoid shoes with slick soles. Tightly laced athletic shoes are fine for learning the basics. As you become more skilled, you may want to try shoes made especially for rock climbing. They will allow you to feel the rock with your toes and twist your feet to fit into cracks. The sticky rubber of the flexible soles will help you grip tiny footholds.

Climbing shoes fit very tightly to help prevent your feet from turning inside them. That support can give you better balance as you stand on small footholds.

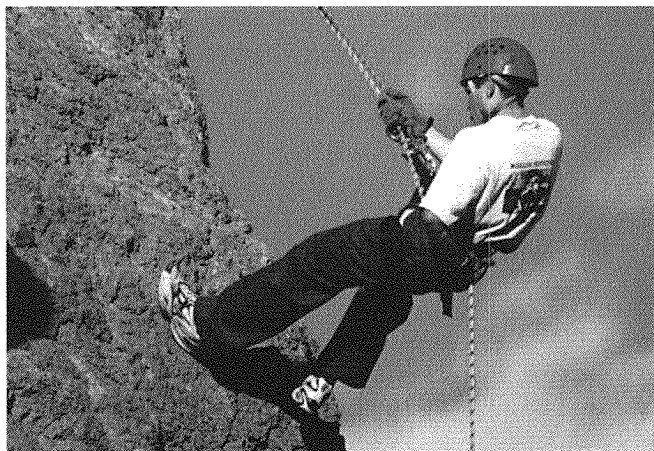

Before climbing, rappelling, or belaying, remove belt buckles, wristwatches, rings, and any other jewelry.

Rappellers can wear gloves with leather palms to prevent friction burns while they are handling the rope. The gloves must be dry and fit well.

Tie back long hair and tuck it into your helmet or into the back of your shirt so it won't become tangled with ropes, belay or rappel devices, or carabiners. If you wear glasses, consider using a strap to keep them from slipping off.

For your first climbs as a beginner, you won't need to take much with you. Eventually, however, if you become skilled enough and want to climb in remote areas, you will need a sturdy daypack or backpack to carry your first-aid kit, compass, map, food, water, flashlight, pocketknife, sun protection, waterproof matches, clothing for protection from wind and rain, and other items necessary for climbs conducted far from a road.

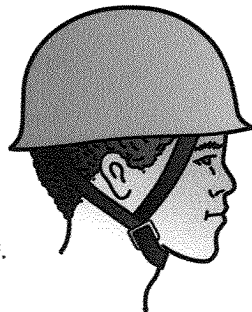
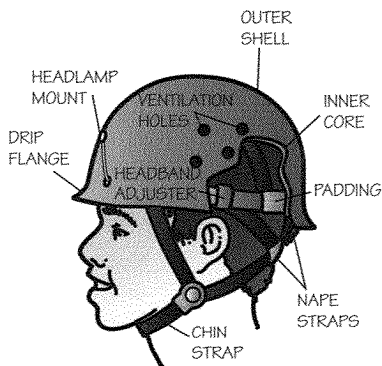

**Climbing helmet features. The helmet should be properly fitted and adjusted.**

Whenever you are climbing, rappelling, or belaying on rock faces, wear a helmet that has UIAA or CE approval and that is designed for climbing. A helmet will protect your head against stones and debris falling from above, and may prevent injuries if you collide with a rock face during a fall. A chin strap helps keep a climber's helmet from falling off or shifting.



The helmets, hardware, and ropes used for climbing, rappelling, and belaying have been developed over more than 150 years of mountaineering. The UIAA (Union Internationale des Associations d'Alpinisme) is a group of mountain-travel experts who set standards and testing procedures for climbing equipment. The CE (Conformité Européenne, which translates to European Community) maintains similar standards for excellence. All ropes, harnesses, helmets, and hardware used by Scouts for climbing, rappelling, and belaying must be specifically designed for climbing. Wear a properly fitted helmet when climbing above shoulder height whether you are on a rock face, tower, or artificial wall. When using an indoor climbing gym, the climbing facility's procedures apply.

## Rope

Rope is the lifeline of climbing. Before the 1940s, the best rope available was manila rope, made by twisting together tough, stringy fibers of the manila plant. However, manila rope may rot if it remains wet for long periods.

Manila rope is also *static*, which means it stretches very little. A falling climber belayed by a manila rope will be yanked to an instant stop. This can put excessive strain on the rope, the anchors, and the climber's body, often causing damage to equipment and/or possibly injury.

After the invention of nylon in the 1930s, manufacturers developed ropes that are *dynamic*, meaning they will stretch. A dynamic rope stops a falling climber gradually rather than all at once, which reduces the shock on the rope and anchor system and helps the climber avoid injury.

Today, the **only** rope approved for BSA climbing and rappelling activities is *kernmantle climbing rope* with a core of parallel or braided nylon strands (the kern) surrounded by a woven sheath (the mantle). When new, static rope must have a breaking strength of at least 22.2 kiloNewtons (5,000 pounds). Climbing ropes must be dry and treated with care before storage.

**Construction of a kernmantle rope with its woven sheath (the *mantle*) over a braided core (the *kern*)**

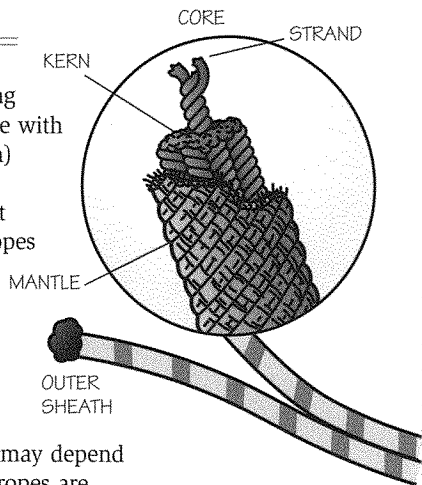

## Rope Inspection

Your life and the safety of those climbing with you may depend upon your rope being in good condition. Climbing ropes are very strong but they can be damaged. Before each day's climbs begin, perform an inch-by-inch hand and eye inspection of any rope you plan to use. Search for cuts or abrasions, fraying, puffs of fiber, soft or hard spots, lumps, stains, or fused areas that are smooth and slick. Tie a figure eight on a bight in one end of a rope to indicate that it has been inspected.

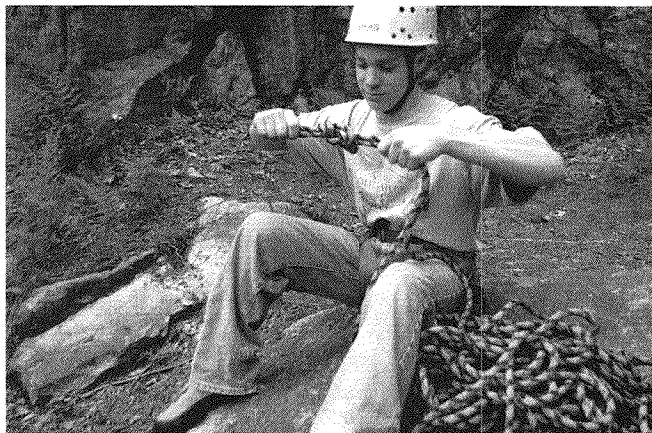

**After a rope has passed inspection, tie a figure eight on a bight in one end.**

Do not use any rope that shows signs of damage. Bring it to the attention of climbing instructors and directors. They will remove the rope from service and, if necessary, retire an unsafe rope by cutting it into pieces no longer than 15 feet.



## Rope Care

The following guidelines will help you protect a climbing rope from damage.

- Never step on a rope or drag it along the ground. Dirt and tiny bits of sand can cut the sheath and may even penetrate to the core and weaken the rope.
- Never pull a rope over a sharp edge, especially if it is bearing weight. Route the rope away from sharp edges and narrow cracks that might cut it, or protect the rope by placing canvas pieces between the rope and the rock.
- Protect rope from heat.
- Never allow a rope to run over another rope or a piece of nylon webbing. Friction between the two can harm the stationary webbing or rope, and perhaps wear through it.
- Never leave a rope stretched or under tension for extended periods of time.
- If possible, keep rope dry. Before putting it into storage, let wet rope air-dry in a place safe from direct sunlight.
- Keep rope away from chemicals and petroleum products, which can erode and weaken nylon.
- Prolonged exposure to sunlight damages nylon rope. Don't leave rope out in the sun any longer than necessary.

You can wash a rope to remove dirt and rock crystals that might shorten its useful life. Wash a badly soiled rope by hand or in a front-loading washing machine with cool water and a mild laundry soap that does not contain bleach. When using a washing machine, place the rope in a large net bag first so there is no danger of rope ends becoming entangled in the washing machine mechanism. Thoroughly rinse the rope, then air-dry it completely (out of direct sunlight, and don't use a dryer) before using the rope again or putting it into storage. Be patient—it may take several days for a rope to dry.

## Coiling or Bagging a Rope

A typical climbing rope is 50 meters (165 feet) long and 11 millimeters ( $\frac{7}{16}$  inch) in diameter. Coiling or bagging a rope keeps it in a neat package that is easy to carry and store. You can also loosen a coiled or bagged rope without its becoming a tangled mess. This is especially important when throwing a rope down a cliff for a belay or rappel.

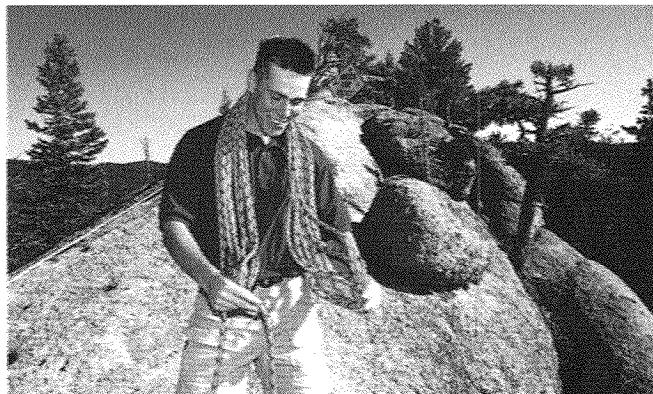

As you coil a rope, drape lengths of it around your neck.

Begin a coil by removing any knots and hardware from the rope. Starting about 10 feet in from one end, drape lengths of the rope over the back of your neck so that the loops hang down below your waist.

When you are about 10 feet from the other end, remove the loops from your neck, grasp the two ends of the rope, and wrap them several times around the coil. Thread a bend of the remaining rope lengths through the coil, then pass the ends through the bend and pull it snug. For a convenient way to carry a coil, some climbers leave enough of the two ends to place them over their shoulders and around the coil, then tie the ends around the waist. This is called the *butterfly coil*.

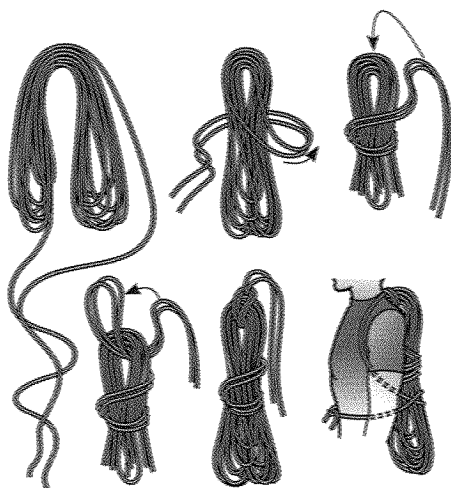

Butterfly coil

### Storing Rope

To store a rope overnight or for a few days, coil it or bag it and put it in a safe place that is dry, clean, cool, and shady. For longer storage, make sure the rope is dry and stowed away from sunlight, heat sources, petroleum products, chemicals, or dirty areas. Do not store a rope in the trunk of a car, where heat, battery acid, or other chemicals could damage the rope. (See also "Storing Equipment" later in this chapter.)



It is best to store or carry a rope in a rope bag. Some rope bags are stuff sacks. Others open up to include a tarp that protects the rope from sand and dirt.

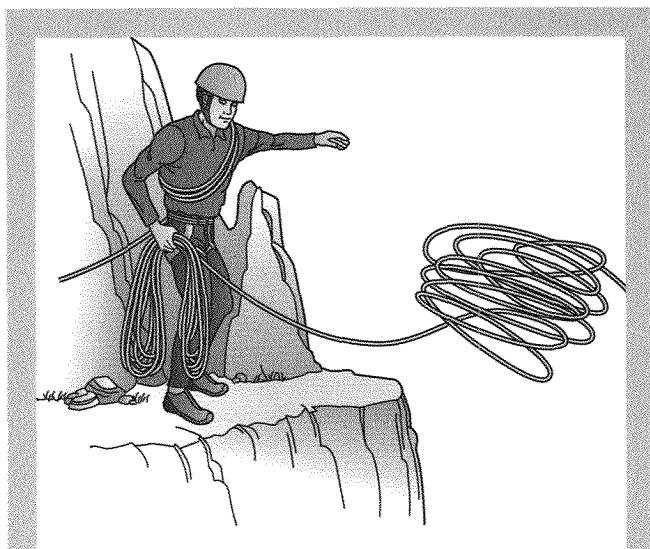

## Throwing a Rope Down a Cliff

Climbers can waste a remarkable amount of time untangling ropes that have been improperly thrown. For orderly rope handling, follow these steps.

- Secure one end of the rope. It should be clipped into an anchor, or simply grasped tightly, but it must be held in some way.
- Shout "Rope!" and then wait a moment. This standard signal warns anyone below to be alert for falling rope. If for some reason the rope should not be thrown, someone should immediately shout that information up to the person holding the rope.
- If the rope has been coiled, loosen any loops used to hold the coils together. Split the coil in half. Toss the half closest to the anchor first and, once it has straightened itself, toss the other half down the cliff.
- If the rope is in a rope bag, secure one end of the rope and then toss the bag over the edge of the cliff. The rope should feed out neatly as the bag falls.

## Carabiners

Carabiners should be used so that the load is distributed along the ends of the oval, the strongest alignment. Never load the carabiner along its gate, and avoid cross-loading (twisting the load across the gate), which could force the gate open.

Carabiners are the essential connectors of belay and rappel systems. They are used to attach climbers, rappellers, and belayers to ropes and anchors, and to clip together ropes and runners, or loops of webbing. (See "Webbing" in this chapter.) Most carabiners are made of aluminum alloy or high-grade steel. A spring-loaded gate on one side allows a carabiner to be snapped onto a rope or piece of webbing. Carabiners have a variety of shapes: oval, D-shaped, and pear-shaped (also called HMS).

*Locking carabiners* have a sleeve that you screw or twist with your fingers to lock the gate closed (take care not to overtighten the sleeve). With *double-locking carabiners*, a climber must twist and pull the gate to open it; this system provides added protection against an accidental opening. Carabiners should be oriented with the gate down. When two *nonlocking carabiners* are used together, the gates should be reversed so that when they are pressed open the gates form an "X." This helps prevent both from being unintentionally opened at the same time.

Inspect carabiners for any signs of damage or wear. Make sure the gates work smoothly and close cleanly. Do not drop carabiners on hard surfaces, drag them along the ground, or otherwise mistreat them. Grooves worn into the metal by friction from ropes can weaken a carabiner. Retire from use any carabiners that have become significantly grooved or bent, or that have been dropped from a significant height onto a hard surface.

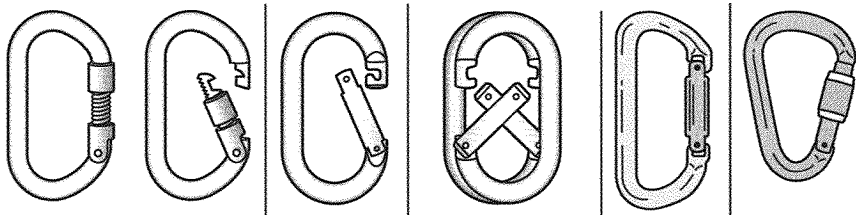

**Locking D-shaped**  
The locking carabiner helps protect against accidental opening.

**Nonlocking oval**

**Always use nonlocking carabiners in pairs, with the gates of the carabiners reversed.**

**Nonlocking D-shaped**

**Locking pear-shaped**

## Webbing

Webbing designed for climbing is available in a variety of sizes, lengths, and materials such as nylon, Spectra, and Dyneema. Tubular webbing (usually 1") is used to form tied-seat harnesses; for anchors used by belayers and rappellers; and for other uses in climbing, rappelling, and belaying. A piece of tubular webbing can be made into a loop known as a runner in one of two ways: The ends are commercially sewn together, or the ends are tied with a water knot and can be backed up with safety knots. Climbers use runners—or *slings*, as these loops are also called—for rigging anchors, managing rope, and many other tasks.

Like all climbing rope, all webbing can be harmed by friction, dirt, and long exposure to sunlight or harsh weather. Dispose of webbing that shows any sign of damage or that has an unknown history.

## Storing Equipment

Take time to store equipment correctly so that it will last longer and be in good shape the next time you want to use it. First, remove all webbing and ropes from anchor points. That will prevent gear from being left out in the elements and will ensure that the next climbers and rappellers set their own anchors with equipment they know to be reliable. Coil each rope or stow it in a stuff sack. Carabiners and other hardware can be clipped together, snapped onto a loop of webbing, or stored in duffel bags. Inspect runners and harnesses, too. Destroy and dispose of any equipment that might pose a danger; store the rest in duffel bags.

**Gear slings or short lengths of webbing can be used to help organize climbing gear.**

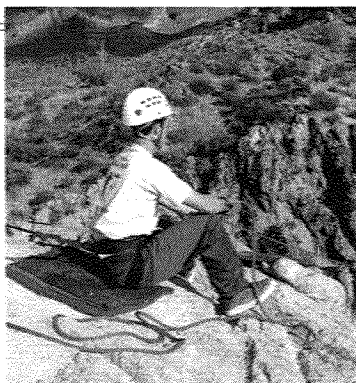

**Belayers use tubular webbing to anchor themselves securely.**

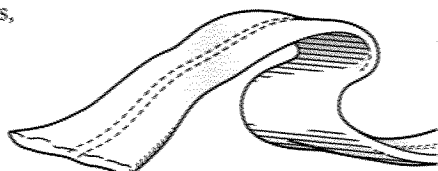

**Tubular webbing**

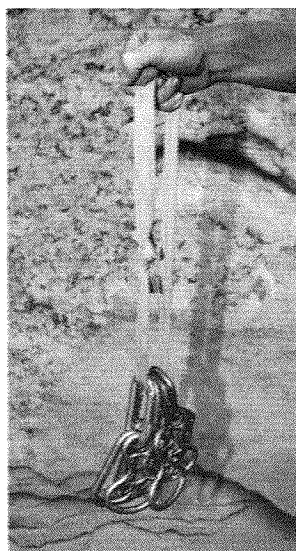

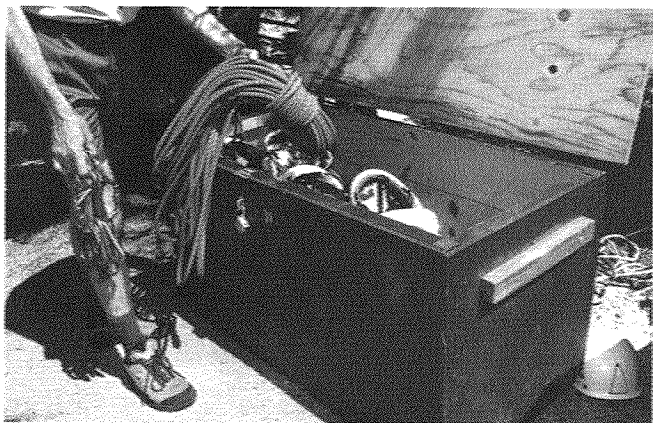

Always take time to store equipment properly so that it will provide better safety and longer service.



If you notice any damage to a rope or piece of equipment, immediately “retire” it so that it cannot be used again. Cut a damaged rope into 15-foot or shorter lengths that can then be used for knot-tying practice or disposed of in the trash.

Rope and gear that have gotten wet must be dried completely before storage. Uncoil wet rope and drape it loosely and out of direct sunlight so that air can get to it. Hang damp slings and harnesses from rustproof hooks.

Directors and instructors at climbing areas may ask you to help fill out the detailed records that are kept to track the history of each rope and piece of equipment. Those records are an important tool for making sure that only ropes and gear in top condition are used during climbing and rappelling activities. Users should be aware of which ropes and other gear endured hard falls; this information must be noted in the written histories of the equipment and factored into equipment retirement decisions.





## Knots

Rope is such an important part of climbing and rappelling that you shouldn't be surprised to discover that tying knots is a basic skill all climbers must learn. A good way to learn climbers' and other knots is to carry a 2-foot piece of parachute cord in your pocket. When you have spare time—while waiting for a bus, for example—you can pull out the cord and run through your collection of knots.

Practice tying knots before you go climbing. Continue practicing so that the knots become natural to your fingers and you can tie them almost without thinking. You should be able to tie all of the basic climbers' knots quickly and neatly with your eyes closed, especially if you plan to go on to more advanced Class 5 climbing.

### Safety Knots

A safety knot, or *stopper knot*, added to a knot such as a figure eight follow-through will help keep the free end of a rope from working itself back through the primary knot. This effective safety knot is also called the *barrel knot*, *one-sided grapevine knot*, and *half a double fisherman's knot*. Form it by loosely looping the tail of the rope twice around the standing part; run the end up through the two loops thus formed (the same method used to tie the first portion of the double fisherman's knot, described later in this chapter). Work any slack out of the safety knot so that it lies snug against the knot it is protecting. Use the overhand or half hitch as a safety knot in webbing.

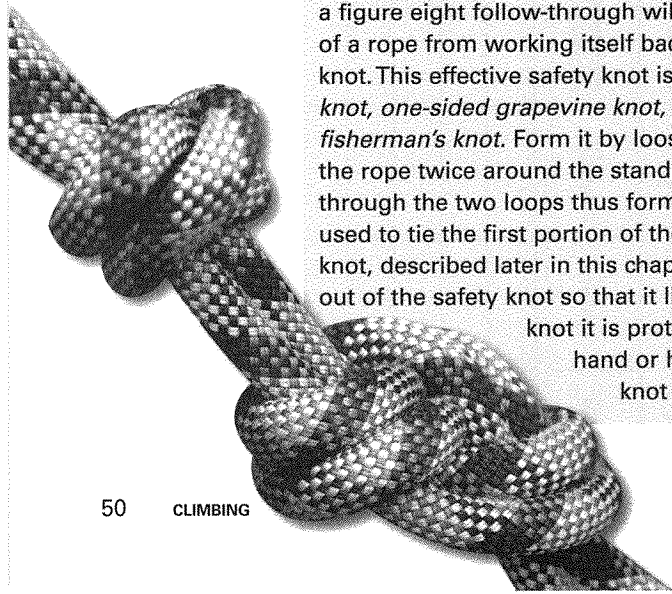

## Figure Eight on a Bight

Forming a *bight*, or bend in a rope, and then tying a figure-eight knot with it gives you a loop that will not slip or come loose. Snap a carabiner into the loop, and the rope can be attached to an anchor sling. Back up this knot with a safety knot when it is tied in the end of a rope.

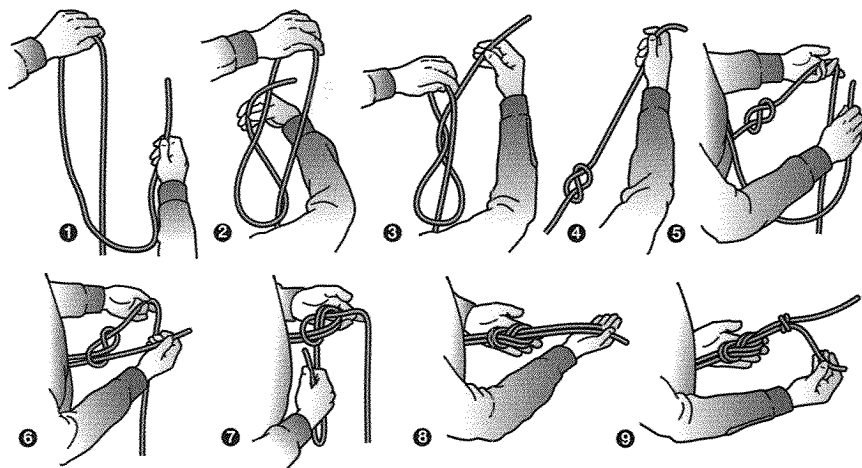
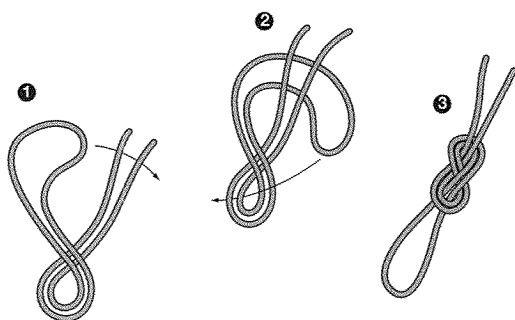

## Figure Eight Follow-Through

This is the same knot as the figure eight on a bight, but with an important difference. The figure eight on a bight must be tied in a rope before it is attached to a carabiner, while the figure eight follow-through is tied directly to a harness.

Begin a figure eight follow-through by tying a loose figure-eight knot in a rope (steps 1 through 4 in the above illustration). Run the end of the rope through the climbing harness or the device to which you want to attach it (step 5). Then trace the end of the rope back through the figure-eight knot in the opposite direction (the "follow through," steps 6 through 8). Back up the figure eight with a safety knot (step 9).

## Water Knot

A water knot protected by safety knots can be used to tie together the ends of a piece of 1-inch tubular webbing to make a runner for use in anchors, and to tie some seat harnesses. The water knot seldom slips once it has been tightened by weight, but it can be very difficult to untie after being tightened. Back it up with safety knots.

Tie an overhand knot in one end of the tubular webbing (step 1), leaving at least a 6-inch tail. With the other end of the webbing, trace the first end all the way back through the overhand knot (steps 2 and 3), again leaving at least a 6-inch tail. Straighten the knot so that the webbing surfaces lie flat against one another, then pull it as tight as possible (step 4). You may choose to back it up with safety knots (step 5).

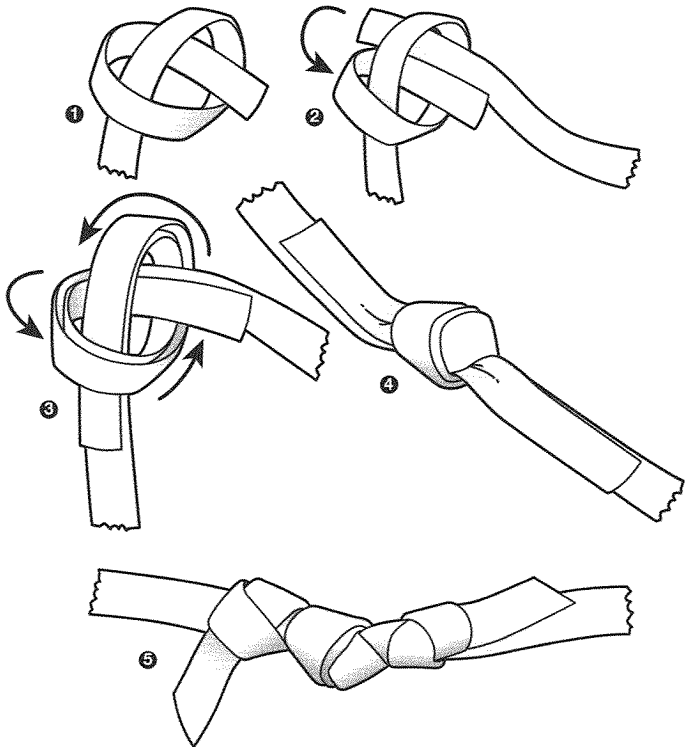

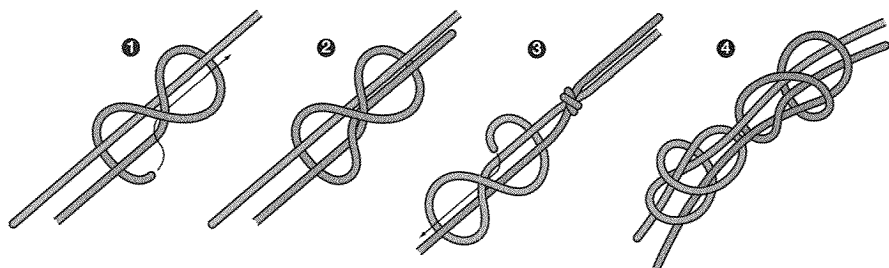

### Double Fisherman's Knot (Grapevine Knot)

For tying together the ends of two ropes, the most reliable knot is the double fisherman's knot. It can also be used to secure the ends of a piece of cord to form a runner. Half of a double fisherman's knot (also known as a barrel knot) can be used as a safety knot to back up a primary knot such as a figure eight on a bight.

Lay about 2 feet of the ends of two ropes alongside one another, ends opposite. Loosely loop one rope end twice around the other, then thread the end of that rope through the loops. Repeat the process with the second rope end. Carefully tighten the two parts of the knot, then slide them against each other. If they don't fit together neatly, the knot is incorrectly tied.

### Prusik Knot

The Prusik knot secures a loop of smaller rope or accessory cord to a climbing rope in such a way that it can be slid along the rope, but when it is loaded will bend the rope and hold securely. The knot is commonly tied with accessory cord by a climber to ascend a rope or to secure a belay system in order to release the belayer.

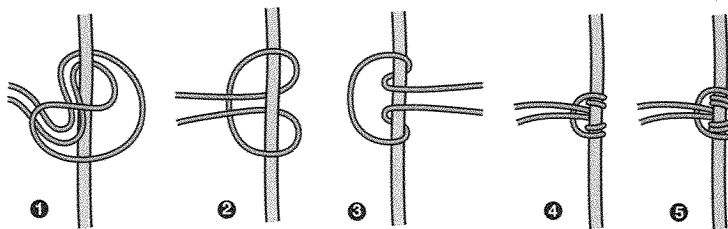

# Harnesses, Anchors, and Belay Systems

Make sure you follow the manufacturer's recommendations when tying or clipping into the harness for climbing, rappelling, and belaying. Some harnesses have distinct methods of attachment for different activities.

The *protection system* in climbing combines harnesses, ropes, carabiners, anchors, and an alert partner (the belayer) to stop any fall of a climber or rappeller.

## Harnesses

A harness gives climbers, rappellers, and belayers a way to attach themselves safely and reliably to ropes and belay anchors. In a fall, a harness will distribute a person's weight in several directions, which can be safer than if the person had a belay rope tied directly around the waist. A properly fitted harness will place the waistband above the hip bones. Once tightened, it will snugly hold the participant so that the harness can't move up or down.

A harness that will not stay above a participant's hip bones may not hold the person if the participant becomes inverted. The addition of a chest harness or a full-body harness can remedy this.

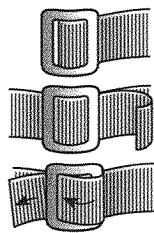

When using a commercial harness, always double-check to make sure you have secured the end of the belt according to the manufacturer's specifications. For most harnesses, that includes threading the belt back through the buckle. Remember, "O" is open; "C" is closed.

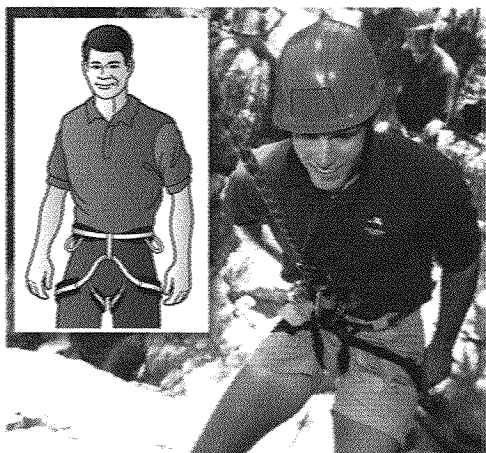

Using a harness that fits properly helps make climbing and rappelling safer, more comfortable, and fun.

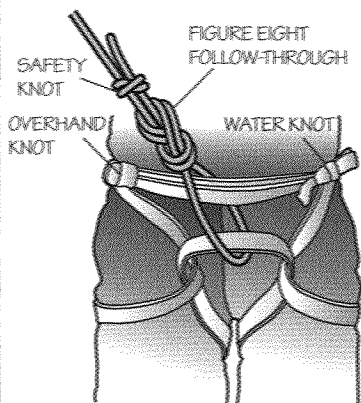

Tied harness

## Commercial Harnesses

Commercially made climbing harnesses usually require only that you put your legs through leg loops and then secure the waist strap with a buckle. The leg loops of some harnesses can be adjusted; you should just be able to slip two fingers between the loop and your thigh. If the harnesses available to you are not adjustable, you will need to choose one that fits your body snugly but not tight enough to restrict circulation.

## Tied Harnesses

A 30-foot length of nylon tubular webbing can be wrapped around your body and tied in special ways to form a reliable tied harness for climbing, rappelling, and belaying. While not as convenient as a commercially made climbing harness, tied harnesses are used in some climbing areas for reasons of economy and to increase the participant's sense of accomplishment. Each tied harness must be tied exactly right every time to ensure your safety. Therefore, you must learn how to tie a seat harness from a qualified instructor. Once you have mastered tying one of these types of seat harnesses, you can use the following descriptions as reminders of the correct methods.



## How to Tie a Seat Harness

Tie the seat harness using a piece of webbing 24 to 30 feet long.

**Step 1**—Drape the center of the webbing behind your neck.

**Step 2**—Step over the ends of the webbing and bring them around the sides of your hips, taking care not to allow any portions of the webbing to cross or twist. Pull the webbing snug.

**Step 3**—Pass the webbing ends behind and then through the lengths of webbing lying against your lower torso.

**Step 4**—Slip the webbing off your neck.

**Step 5**—As you pull out the slack, the bight that had been around your neck will become the horizontal band between the loops of webbing that have formed around your legs.

**Step 6**—Going first behind your back, wrap the remaining lengths of webbing around your waist in this fashion:

**Step 6a**—The piece originally in your right hand goes clockwise.

**Step 6b**—The piece originally in your left hand goes counterclockwise.

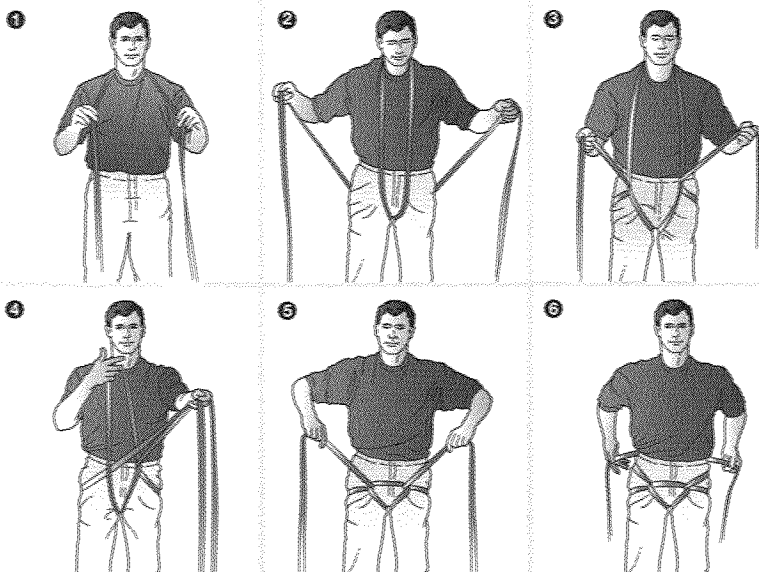

**Step 7**—Continue wrapping until only about 3 feet remains at each end of webbing. Keep the webbing flat and snug against your body.

**Step 8**—Tuck the end of the counterclockwise webbing beneath the sling on your left hip. (You will need it in a moment to finish tying a water knot.)

**Step 9**—With the end of the clockwise webbing, tie a loose overhand knot (half of a water knot) around the wraps of webbing on your right hip.

**Step 10**—Retrieve the other end of the webbing and use it to trace back through the loose overhand knot, thus completing a water knot.

**Step 11**—Tighten the water knot. Check the harness to be sure it fits securely and that there are no unnecessary twists in the webbing. Wrap any remaining length of webbing around your waist and tuck the end under the previous wraps.

**Step 12**—Use a locking carabiner (double-locking preferred) to clip together all the webbing between the knots in front of your body.

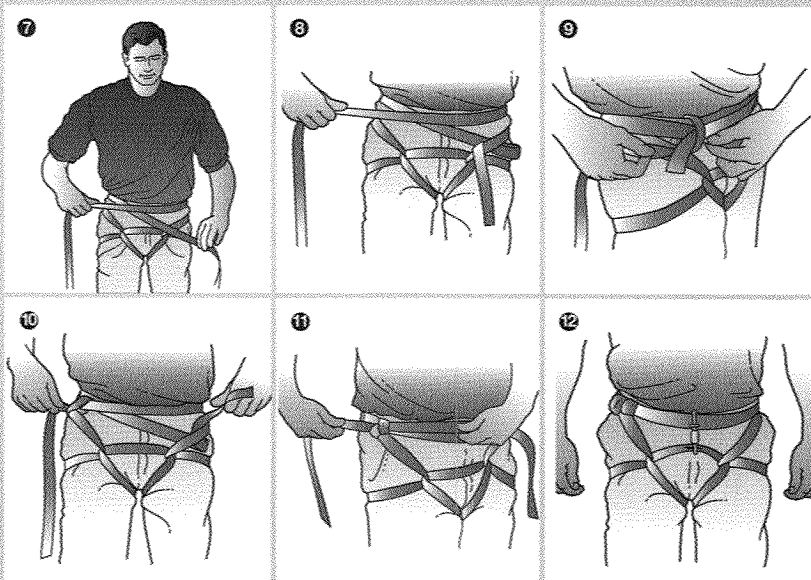

## Anchors and Belay Systems

You have learned about harnesses, ropes, and carabiners. Now let us look at two other essential parts of the protection system: the anchors and the belay system.

### Anchors

Choosing and rigging anchors for climbing or rappelling should be left to experienced climbers who have special training in establishing and monitoring anchor points and belay systems. You can learn a lot from them as they explain the anchors that you will be using for your climbs and rappels. They may even ask you to assist in setting up or taking down anchoring systems. Here is some basic information you might learn.

To protect climbers and rappellers from injury, the system that secures them must be attached to failproof *anchor points*—boulders, sturdy trees, or other points that absolutely will not give way. Every belay system must use multiple failproof anchor points so that the entire system has redundancy, or backup.

Trees should be at least 6 inches in diameter at the point of anchor and firmly rooted. Boulders should be located so they cannot be pulled out of position. Nuts, chocks, bolts, and other forms of artificial protection are acceptable only if they have been placed by qualified people.

Deciding where to place an anchor depends upon the way it will be used. If a belayer will be at the top of a climb, it is better to find an anchor 6 to 10 feet back from the edge of the cliff. This will allow room for belayers to do their work and for climbers completing their routes to move about without danger of falling. Special care must be given to protect the rope from sharp edges.



Never assume an existing anchor point is safe because it has been used in the past. Check every anchor every time you intend to use it. Webbing and rope left on-site by previous climbing parties may have been damaged by heavy use or exposure to the elements. Replace anything you find that was left attached to an anchor with equipment you know to be in top condition.

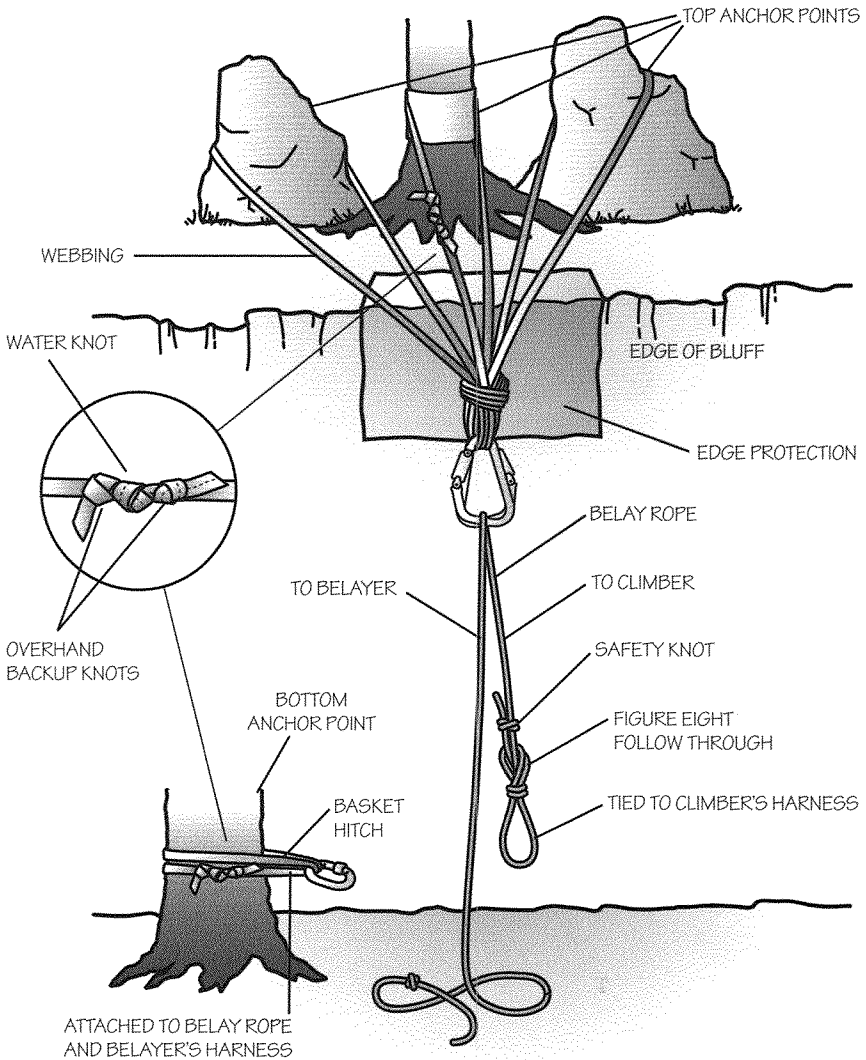

**Belaying a climber from below.** Here is how to set up a belay system using a tree at the top of a cliff as the top anchor point, and a tree at the base of the cliff as the belayer's anchor point. Make the anchor webbing long enough to allow the carabiners securing the rope to the top anchor to hang over the edge of the cliff. That helps prevent the rope from being abraded, or scraped.



Whenever possible, use one or more *backup anchors*.

If the primary anchors fail, the backups can keep you safe.

**All anchors must be failproof or backed up and the load distributed as equally as possible.**



**A cordelette anchor system divides the force of a load among several anchor points.**

Runners or ropes must be correctly attached to anchors to safeguard the lives of climbers, rappellers, and belayers. Always follow the guidance of a climbing area's instructors when selecting and rigging anchor points. Make sure rope does not run over any edges that could abrade or cut it. Don't let carabiners under tension lie against edges where they could be damaged.

### Belay Systems

A belay system provides protection to climbers and rappellers whenever their feet are higher than shoulder-height above the ground. If they slip, the belayer can help guard them from injury by quickly stopping the fall. Climbers and rappellers can be belayed either from above or from below with a top-rope belay. (Study the photos and illustrations in this section to see how the setups differ for each method.)

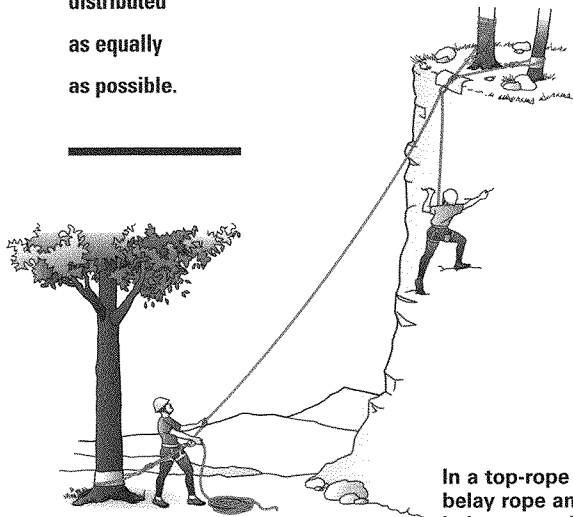

**In a top-rope belay, a climber is protected by a belay rope anchored at the top of a climb. The belayer may be at the top or bottom of the cliff.**

The belay rope passes through a *belay device*—a piece of hardware shaped to increase a belayer's control over the rate at which a rope will move through the device. Friction plays an important role. More friction between a rope and a belay device means a slower descent for a climber or rappeller. Less friction allows the rope to move more quickly. Most belay devices are easy to use and highly reliable. A belayer does not need great strength to stop the fall of a climber or rappeller.



**Bottom belay system setup**

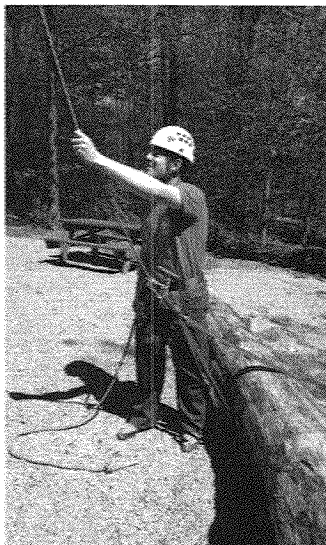

**A belayer properly anchored for a bottom belay**

Prepare to belay a climber or rappeller by putting on a climbing harness and attaching yourself to the belay system with a locking carabiner. The belay should be set up so that the belay device is directly connected to the anchor system. The belayer clips into the carabiner attached to the belay device or into the loop of webbing just below it. Make sure you are in line with your anchor system and the direction of pull on the rope in the event of a fall. This will prevent your being yanked out of position.

---

Belay and rappel devices apply friction to the rope, allowing its speed to be controlled. An appropriate commercially made belay or rappel device with a locking carabiner must be used. The belayer must have had prior training or experience using the specific type of device.

---

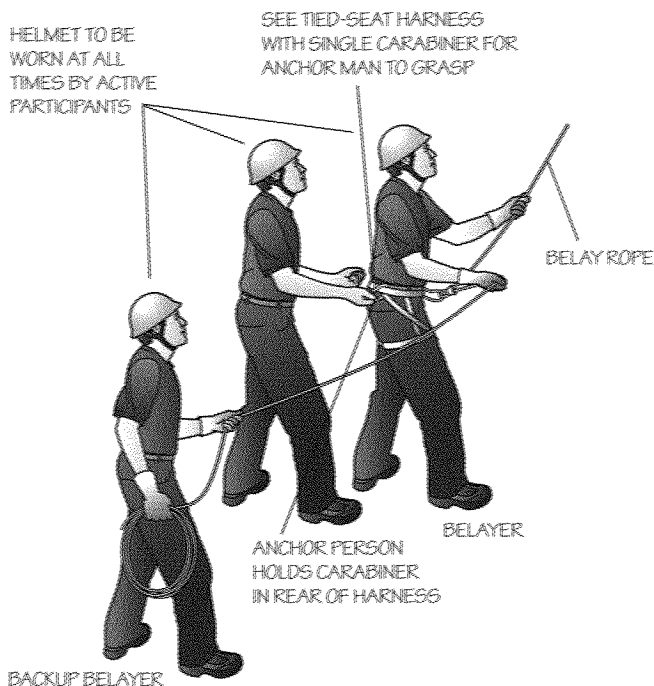

Always follow the guidance of a climbing area's instructors regarding the belaying technique to be used and the way you anchor yourself to act as belayer. Another acceptable variation is to anchor a belayer on the ground with a second belayer tightly gripping the first belayer's harness and using body weight to keep the first belayer in place.

### **BELAYING A CLIMBER**

After you are connected to a belay system, insert a bend of the belay rope into the belay device. Use a locking carabiner to secure the bend of rope and the keeper loop of the device to your harness or directly to an anchor system.

The preferred method is using a direct connection to the belay anchor, rather than having the belayer hooked to the anchor, thus becoming part of the anchor.



Arrange the rope so that your stronger hand (usually your right hand if you are right-handed) will be the *brake hand*—the hand closest to the free end of the rope. Your other hand will be the *guide hand*, resting on that part of the rope leading to the climber or rappeller. (Specialized belay devices such as the Grigri are set up a little differently. Refer to the manufacturer's guidelines.)

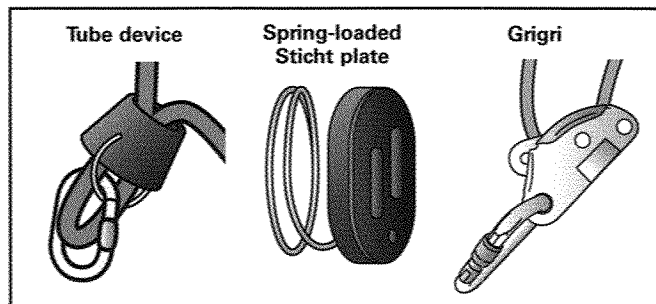

Double-check the belay system to be sure it is correctly anchored and that the belay device is ready. Exchange verbal signals (see the boxed text later in this chapter) with a climber. As the climber ascends, pull through the belay device any slack that forms in the rope, and let the loose rope pile up next to your feet. While holding the rope firmly with your brake hand, slide your guide hand out along the rope. Then clasp both sections of the rope with the fingers and thumb of your guide hand so that you can slide your brake hand back along the rope toward your body. (*Your brake hand must never leave the rope.*) Repeat the process. Keeping slack in the rope to a minimum will limit the length of a fall if the climber slips.

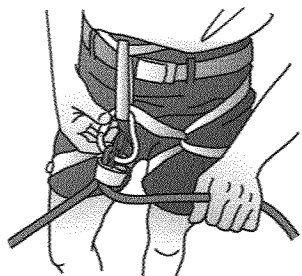

Running the rope through a belay device allows a belayer to stop a fall easily, just by moving the belay rope to one side.

## Belaying

To take up slack as a climber ascends:

1. Grasp the rope with both hands and feed it through the belay device, pulling the guide hand toward the body and moving the brake hand away.
2. Holding the rope firmly with the brake hand, slide the guide hand out along the rope, away from your body.
3. Use the fingers and thumb of your guide hand to clasp both sections of the rope firmly, then slide your brake hand back toward your body. Begin the sequence again. (*Remember, the brake hand must never leave the rope!*)
4. Whether you are letting out rope or taking up slack, stop a fall by grasping the rope tightly and pulling it back toward the hip on your brake-hand side.

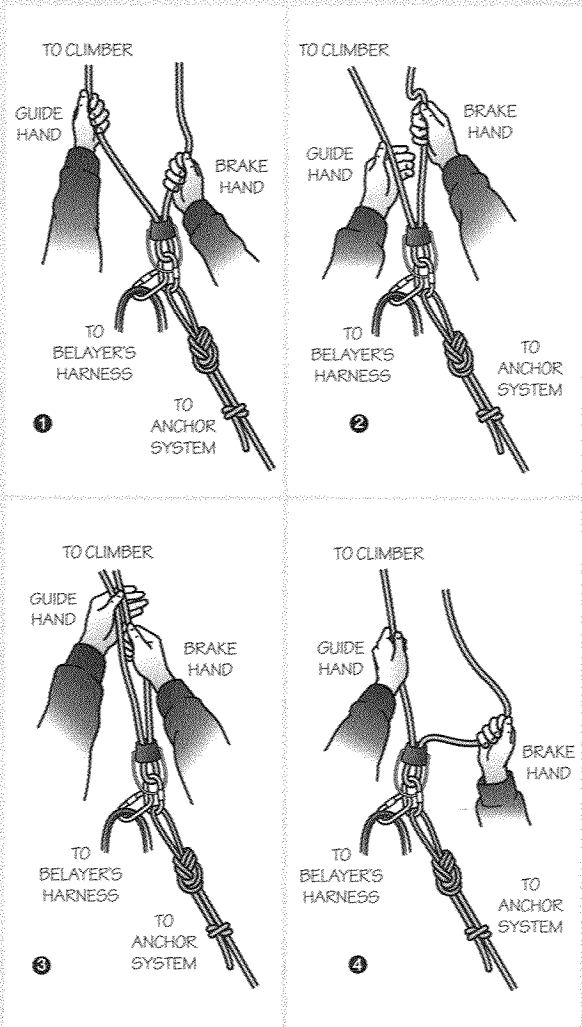

The BUS (brake-under-slide) technique has become popular.

1. **Brake** or lock off the belay rope by pulling downward with the brake hand.
2. Move the guide hand **under** the brake hand.
3. **Slide** the brake hand up toward the belay device.

You are ready to repeat the procedure.

A variation of the BUS is the **chop** technique since the hand movement is similar to chopping wood.

Both hands are brake hands. They pull the rope through the belay device and then lock off as both hands move down. Next, one hand slides up toward the belay device. The other hand slides up toward the first hand.

You are ready to repeat the procedure.

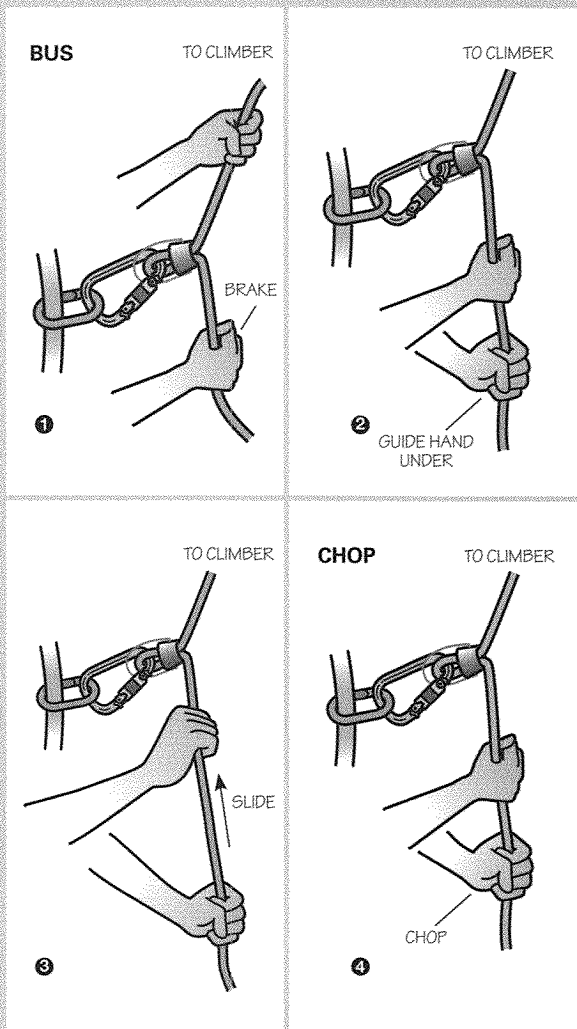

## Verbal Signals for Climbers and Belayers

Verbal signals allow a climber and a belayer to communicate and work together as a team even if they cannot see each other. Get in the habit of using verbal signals every time you are climbing or belaying. If the day is too windy or the area too noisy for climbers and belayers to hear one another clearly, postpone your climbs or move to another area.

Climber	Belayer	Meaning
"On belay?"	→	"Is the belay ready?"
	"Belay on." →	"Your belay is ready."
"Climbing."	→	"Here I come."
	"Climb" or "Climb on." →	"Come ahead."
"Slack."	→	"I need some slack in the rope."
"Up rope."	→	"Take in the loose rope."
"Falling!"	→	"I'm falling! Brake the belay rope!"
"Tension."	→	"Hold the rope tightly in case I fall."
	"Got you." →	"There's tension on the rope."
"Ready to lower."	→	"Lower me."
	"Lowering." →	"I'm letting you down now."
"Rock!"	→	"Rock!" → "Look out for falling objects."
"Rope!"	→	"Rope!" → "Rope being thrown down."
"Off belay."	→	"I'm in a safe place and no longer need a belay."
	"Belay off." →	"I'm no longer belaying you."

A shout of "Rock!" may be the most important climbing signal. It warns everyone that there is immediate danger from something—any object—falling. If you hear this signal, don't look up. Protect yourself in the most efficient way—take refuge under a ledge, move quickly to the left or right, or become "small" under your helmet. Yells of "Rock! Rock! Rock!" warn of more danger than a single shout.

## Verbal Signals for Rappellers and Belayers

Rappeller	Belayer	Meaning
"On belay?"	→	"Is the belay ready?"
	"Belay on."	→ "Your belay is ready."
"Rappelling."	→	"I'm ready to start down."
	"Rappel on."	→ "Go ahead."
"Falling!"	→	"I'm falling! Brake the rope!"
"Off belay."	→	"I'm done rappelling and am in a safe place."
	"Belay off."	→ "I'm no longer belaying you."
"Off rappel" or "Off rope."	→	The rope is free of hardware and is ready for the next rappeller.

### BELAYING A RAPPELLER

Anyone on a single-rope rappel must be protected by an independent top-rope belay. Begin by double-checking the belay system to be sure it is secure, you are properly anchored, and the belay device is correctly set. The bulk of the belay rope should be loosely piled next to you on your brake-hand side. Exchange verbal signals with the rappeller. As the rappeller descends, the belayer gradually releases the belay rope through the belay device.

Anyone using a double-rope rappel may be belayed with an independent belay rope, or with a fireman's belay.

Begin the fireman's belay by positioning yourself at the bottom of the route and grasping both lines of the rappel rope. Exchange verbal signals with the rappeller. As the rappeller descends, be ready to pull down on the rope to slow or stop the rappeller's progress.

## Safety Pointers for Belaying

Belaying is serious business. Every moment that you are belaying someone, you must assume that the person on the other end of the rope is about to fall. Keep your attention focused at all times on the climber or rappeller, and be ready to react instantly to hold the rope and stop a fall. To ensure a safe belay every time, remember these pointers.

- When using an independent rope belay, the belay rope must be correctly anchored in order for the belayer to maintain an effective stance to be prepared to stop the fall of a climber or rappeller.
- The belay anchor system must be absolutely secure and reliable, with no chance of failure.
- The belay device must be properly installed and the belayer must understand how it is used.
- **The belayer's brake hand must never leave the rope.**
- When using an independent rope belay or a fireman's belay, the belayer must anticipate the direction of pull on the belay rope and get in line with it to avoid being pulled out of position.
- The belayer must be ready at any moment to stop a fall.
- The belayer and the climber or rappeller must maintain good, clear communication.
- The belayer's attention must never leave the climber or rappeller.

## Project COPE/Climbing Safety CHECK

**C**LOTHING—No baggy clothing or loose jewelry; hair is tied up or tucked in.

**H**ARNESSES/HELMETS—Properly fitted helmets; ropes properly attached; buckles on harnesses properly secured.

**E**NVIRONMENT—Keep all program areas safe, free from hazards and obstructions, and monitor weather conditions.

**C**ONNECTIONS—Check and double-check—make sure anchor points are rigged properly, participants are properly connected, and carabiners are screwed down and locked.

**K**NOTS—Check that knots are properly tied, dressed, and backed up with a safety knot.

**T H E**  
**R!SK**  
**ZONE™**



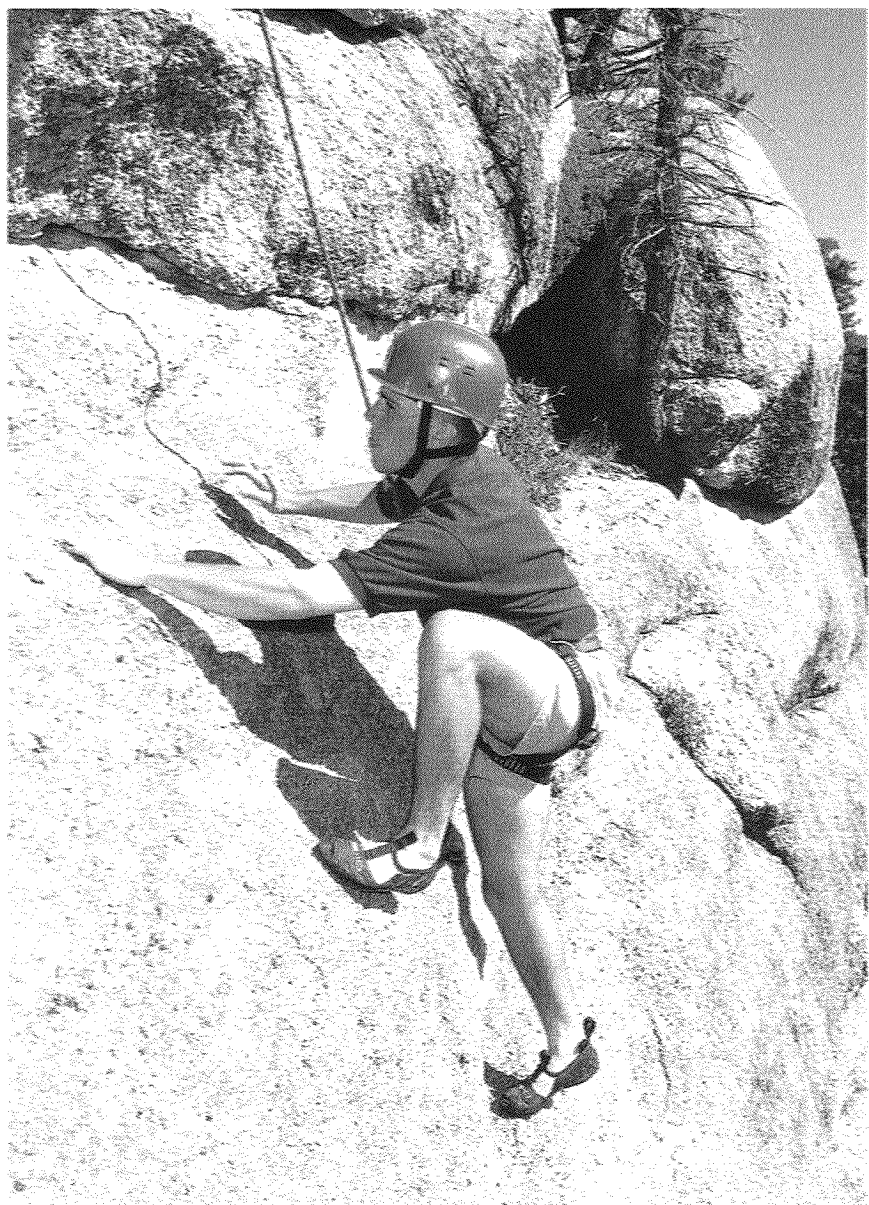

The basic climbing position is the *three-point stance*.



# Climbing

It's time to climb. Begin by putting on a harness. Using a figure eight follow-through knot backed up with a safety knot, tie the belay rope directly into the harness. Double-check your harness and the knots, then exchange verbal signals with your belayer.

You are ready to start your ascent. The basic climbing position is called the three-point stance. This means you keep two hands and one foot on reliable holds while moving the free foot to a new location, or you keep both feet and one hand on holds while the free hand moves. Lift yourself with the strong muscles of the legs; use your hands mostly for balance. Lean out from a wall you are climbing so that your body is vertical and your weight rests on your feet. That will give you the most secure stance as you ascend.

**Tie the belay rope directly into the harness, using a figure eight follow-through knot backed up with a safety knot. Work any slack out of the safety knot.**

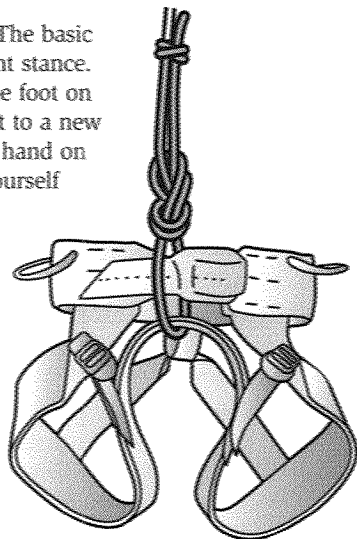

Beginning climbers are sometimes tempted to lean into the rock as if to hug it, but that shifts their weight and can cause their feet to slip off of holds. When your body is too close to the rock, you may also find it difficult to see where your feet are moving.

## Footholds

The size and location of a hold will determine the way you position your foot to take advantage of it. Decide how you will use a hold before you begin moving your body. Place your foot solidly on the hold and keep it still until you are ready to move that foot to its next hold.

The foot techniques most often used are *edging*, *smearing*, and *jamming*. Along with the *rest step*, these are the basic moves for your feet.

**Edging.** Turn your foot sideways and place the edge of the sole on a nub, narrow ledge, or other hold. You probably will find it most natural to edge with the inside of the shoe, although edging with the outer portion of the sole sometimes makes possible a series of moves.

**Smearing.** First, place the sole of your shoe toe against the rock. Then, as your foot bends and takes your weight, the rock will dig into the surface of the sole and hold you, especially if your body is vertical and your weight is directly over your feet. The sticky rubber soles of modern climbing shoes are made for this kind of traction. Both smearing and edging are harder to do with hiking boots or athletic shoes.

**Jamming.** Fit your foot sideways into a crack in the rock and twist your ankle so that your foot is in a more natural position. Your foot should wedge tightly enough against the sides of the crack to hold your weight.

**Rest step.** As your legs tire with the effort of climbing, they may begin to shake. Climbers call this *sewing machine leg*. Use the rest step now and then to give your legs a moment to recover between moves. Place your foot on a wide hold, lock your knee, and let your weight settle onto your heel so that your leg bones support you while your muscles relax. If you have a free arm, shake it to restore circulation and give it renewed energy.

Edging



Smearing

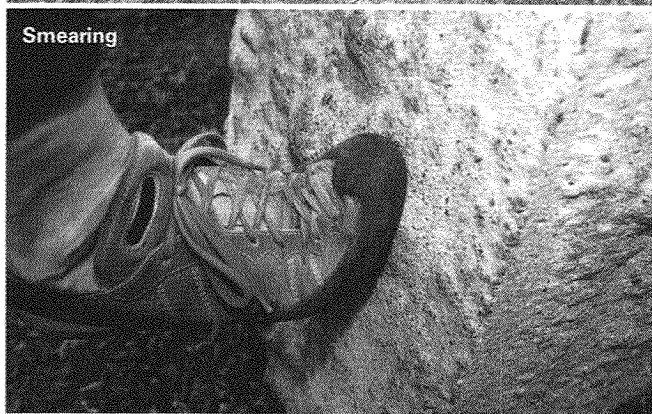

Jamming



## Handholds

You can use your hands in different ways to take full advantage of different shapes of cracks, ledges, and nubs on a rock. *Clings*, *jams*, and *underclings* are among the most common climbing holds.

### Climbers

sometimes call a big hold—using all fingers and the thumb—a bucket or a jug because it is like grabbing the lip of a large container.

**Clings.** Place your fingertips on the edge of a table, bend your fingers at the second joints, and pull down with your wrist. That's a cling hold, the most common way climbers hang onto edges on rock faces. If a hold is small, you might cling to it with only a couple of fingers, perhaps with your thumb braced across the top of your fingers.

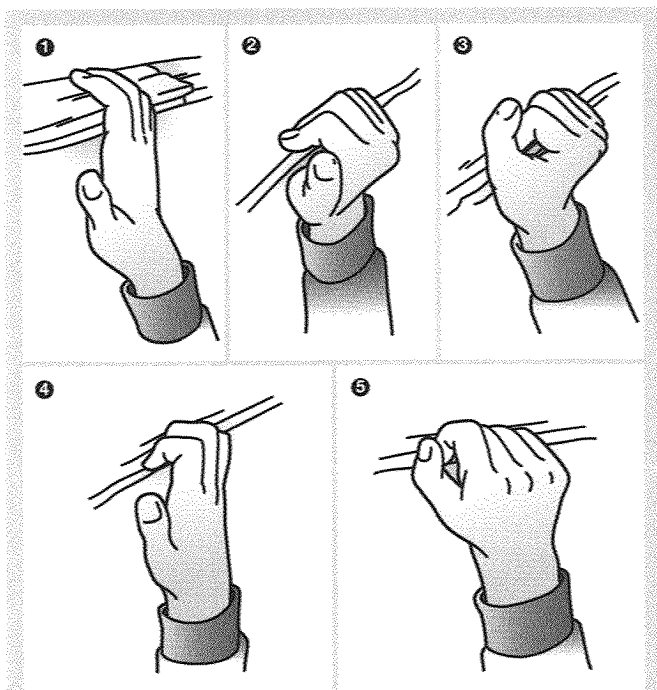

**Clings.** 1. Open grip. 2. Cling grip. 3. Cling grip with the thumb used to support or brace the fingers. 4. Fingertip grip. 5. Bucket or jug grip.

**Jams.** A crack in a wall might be just the right size for you to fit in some or all of your hand. Arch your fingers or clench your fist to tighten your hand in the crack.

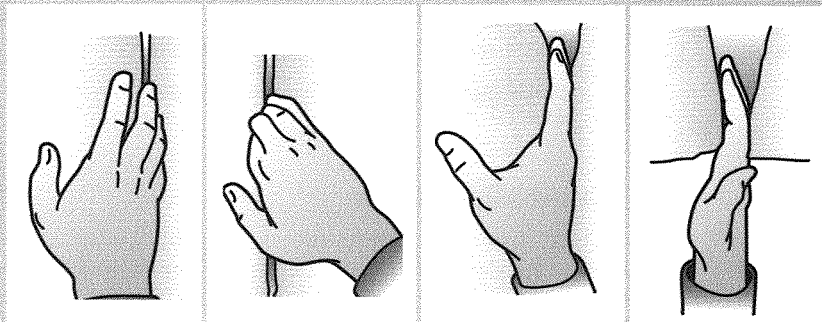

**Finger jams**

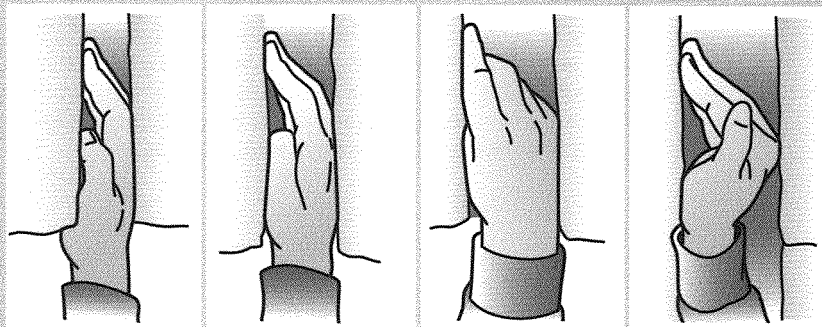

**Hand jams**

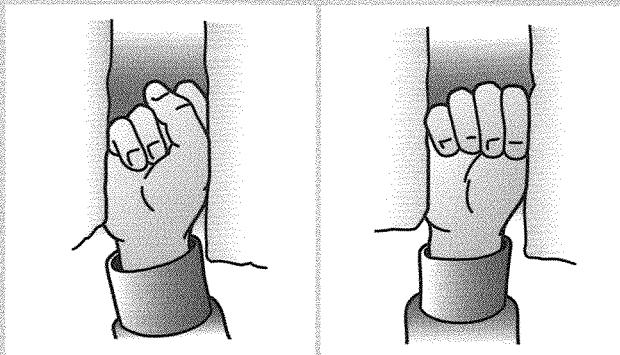

**Fist jams**



**Underclings.** If you are grasping a rock with your palm up rather than down, the hold is an undercling. An undercling works because your hands are pulling one way while your feet are pushing the other. Use the undercling to move sideways along a face, or for balance as you search above for your next handhold.

**Undercling.** The hands pull one way while the feet push the other way.

## Combination Holds

In certain situations, climbers rely on holds that are a combination of handholds and careful foot placement. Combination holds that you may find useful are *mantling*, *liebacks*, *chimneying*, and *counterbalance*.

**Mantling.** With a mantling move, you can hoist yourself onto a ledge or over the top of a wall or cliff. Climb high enough to place a palm on the ledge. Push your body up by straightening your arm, using your legs and your other arm as much as possible. Lift a foot—not your knee—to the ledge, then stand upright just as if you were getting out of a swimming pool.

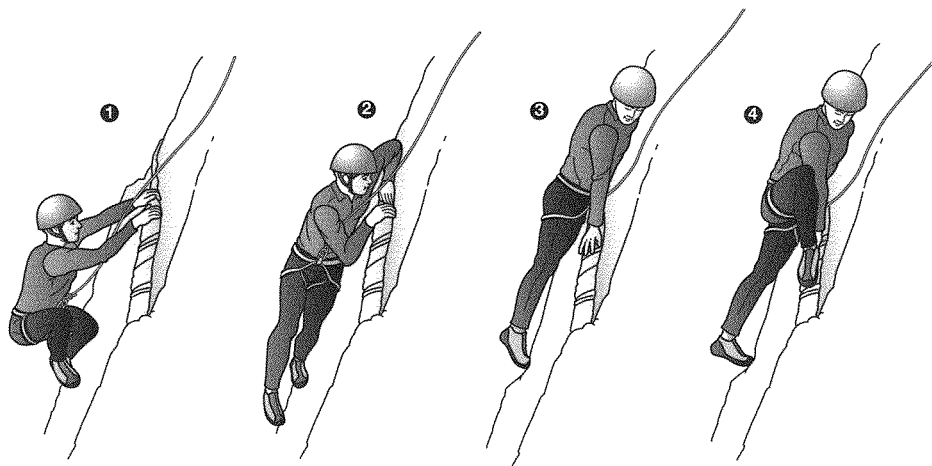

**Mantling.** 1. Approach the ledge. 2. Place a palm on the ledge and cock your arm. 3. Push yourself up as you straighten your arm. 4. Lift a foot to the ledge and stand, balancing your weight over your foot.

**Liebacks.** Use a lieback where two rock faces meet to form a corner. With your hands, hold the crack where the walls join, then push against either rock face with your feet. Moving one foot or one hand at a time (while maintaining three-point contact at all times), work your way up the route. Constant pressure on your hands and feet will prevent you from falling.

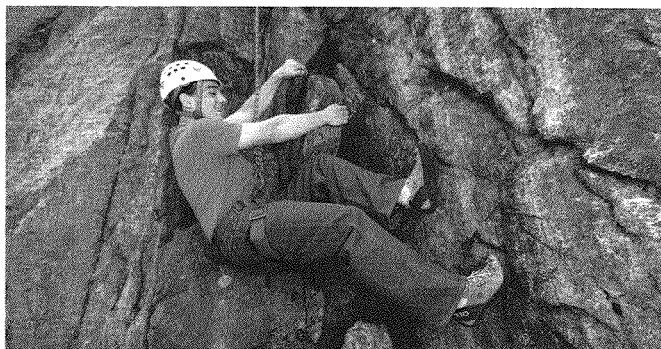

**Lieback**

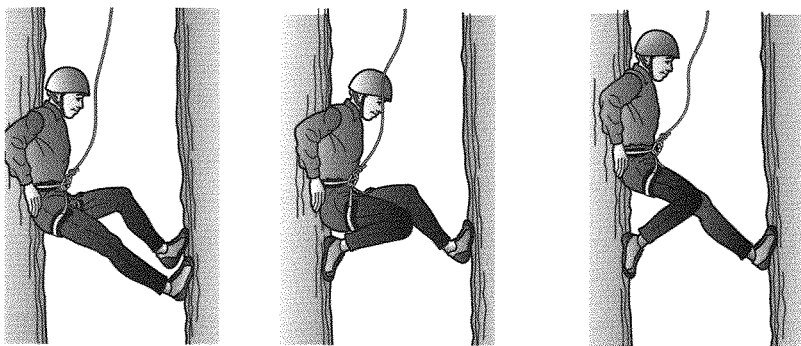

**Chimneying**

**Chimneying.** If a crack in a rock face is wide enough—what climbers call a *chimney*—you can press your back against one side and your feet against the other, keeping your hands low and pressing with the palms. Or you can press one foot and one hand against each side. Move upward by “walking” up with your feet and pushing with your hands against the sides of the chimney. As you straighten your legs and push with your hands, your back slides upward against one side of the chimney.

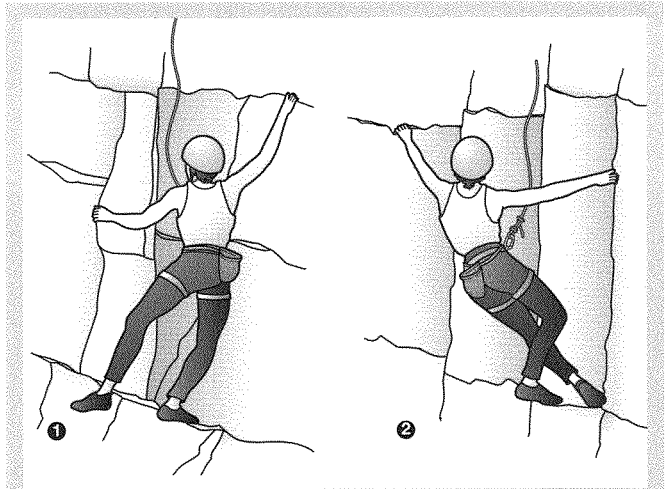

**Counterbalancing.** 1. The left foot is extended to the side to provide counterbalance. 2. The left foot is flagged in front of the right for counterbalance.

**Counterbalancing.** A climber can sometimes extend a leg or an arm to a position that does not offer a solid hold, but rather provides balance during an ascent. Counterbalancing involves the entire body, using position and weight distribution to make the most of minimal holds.

## Tips for Climbing

- Try to support most of your weight on your feet to keep from tiring your hands and arms. Stretch for high handholds only when necessary.
- Practice. Reading about climbing won't build your climbing skills; only practice (under the supervision of a qualified instructor) can do that.



## Planning Routes

Study a wall or rock face before you start climbing, and try to figure out where your hands and feet will go. You will have a better chance of putting together a smooth sequence of moves. Experienced mountaineers call this "climbing with your eyes." As you begin, look ahead for the next two or three holds you can use.

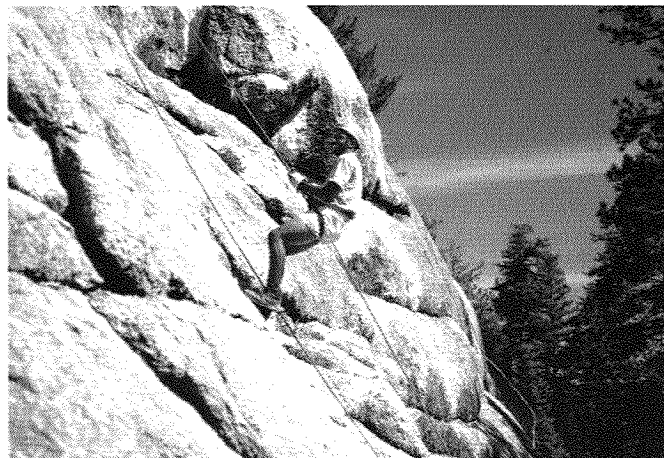

Rock face suitable for climbing



Crumbling and excessively fractured rock face

---

**Chalk.** Advanced rock climbers sometimes use chalk to help keep their fingers and palms dry and improve their grip on the rock. Kept handy in a small bag hung around the climber's waist, the chalk is the same kind that gymnasts use. Some climbing areas discourage its use but will allow chalk that is the same color as the rock or transparent. If you try chalk, use it lightly and only when needed to avoid affecting the environment.

---

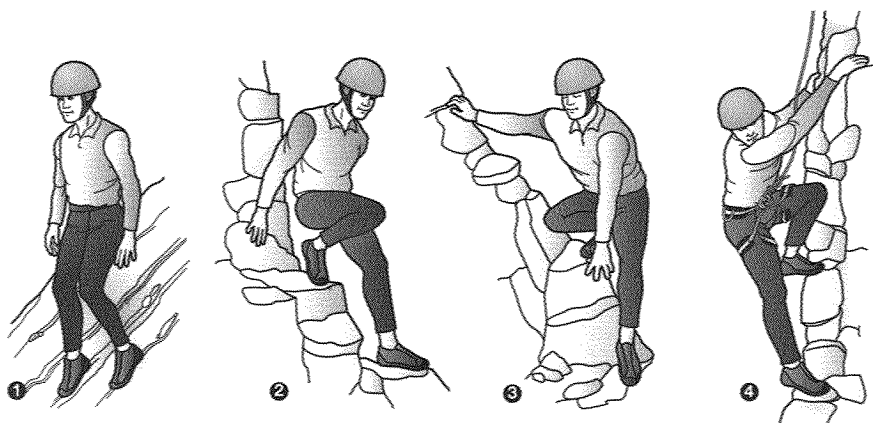

**Down-climbing.** 1. Nose-over-toes on gentle slope. 2. Facing out. 3. Facing sideways. 4. Facing the rock. A helmet is needed anytime danger from falling rock or objects exists. A rope and harness are needed whenever the climb exceeds the climber's comfort level.

### Climbing Down

Climbing down a cliff (called *down-climbing*) can be more difficult than going up, because you might not be able to see the holds as well. On gentle slopes, face out and lean forward in a *nose-over-toes* position to keep your weight over your feet. Turn sideways on steeper terrain. As you descend, keep at least one hand on the rock for balance. On the steepest walls, face the rock and use the three-point stance. Lean out to keep your weight over your feet and to give yourself the best look at the holds below.

### Bouldering

Bouldering is a good way to learn climbing techniques. Bouldering takes its name from climbers practicing their moves on real boulders, but it can also be done on any face that has handholds and footholds near the ground. The key to bouldering is that climbers move up, down, and sideways without ever getting any higher than they can jump down without injury. The goal is not to reach the top of anything, but rather to move smoothly from one hold to the next. Boulders often climb sideways, just above the ground, for extended distances. Such *traversing* builds strength and skill.

Do not climb unroped more than shoulder-height above the ground. If you want to climb higher, you must be on belay. Even if you are climbing only a foot or two high, you must have two or three *spotters* ready to steady you and provide assistance if you fall.

**Bouldering** can be done on any face that has handholds and footholds near the ground on which climbers can practice their moves. Boulders rely on spotters to be their "safety net" in case of a fall.

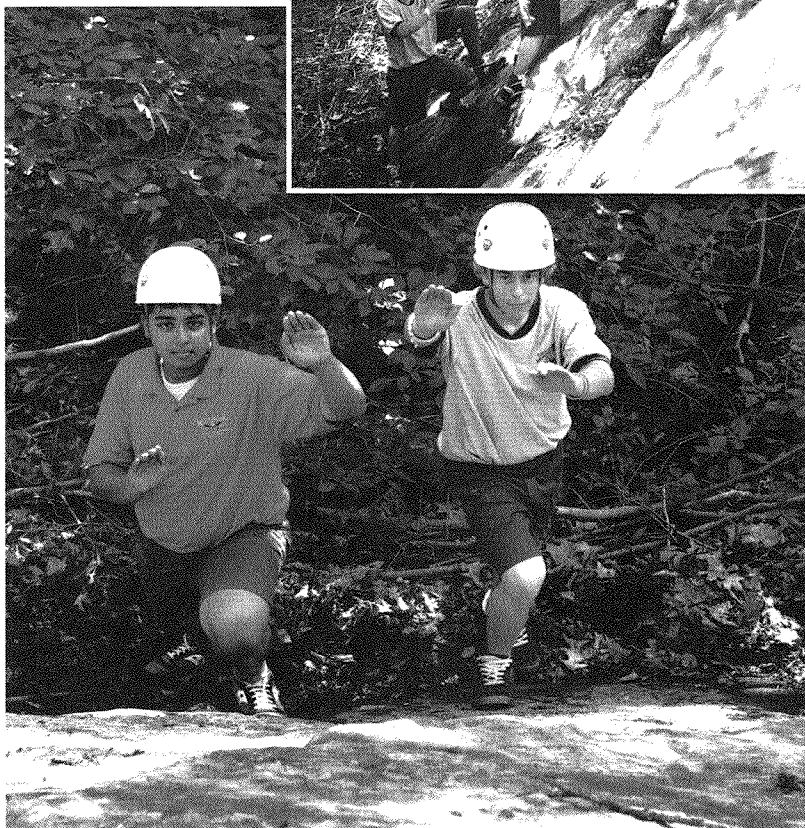
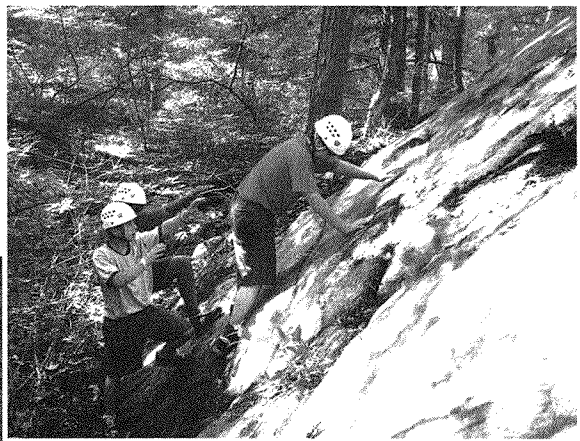

## Spotting

Spotters stand ready to break a person's fall in such a way as to prevent injury either to the person who falls or to the spotters. They are not expected to catch a falling boulderer in midair—something that is impossible in most cases, even in a fall of just a few feet. Instead, they support the head, neck, and torso of the falling person and ease the boulderer to the ground. To do this, spotters must

- Position themselves with their hands ready to support a faller, keeping their hands out in front of them with their fingers and thumbs together. Spotters should keep their feet apart with one foot in front of the other for stability, and their knees and elbows flexed to help absorb the shock.
- Stay alert and focused on the boulderer they are spotting.
- Assume personal responsibility for breaking the person's fall.

## Verbal Signals for Boulderers and Spotters

The verbal signals that spotters exchange with boulderers allow spotters to be positioned and prepared for whatever situations may arise.

Boulderer	Spotters	Meaning
"Spotters ready?"	→	"I'm ready to start."
	"Ready." →	"I'm ready to protect you."
"Climbing!"	→	"I'll start up as soon as spotters give a go-ahead."
	"Climb on!" →	"Go ahead."
"Falling!"	→	"I'm about to fall."

## How to Fall

Falling is a natural part of learning to climb. Even expert climbers sometimes lose their grip when they are attempting difficult moves. Rappelers, too, can slip off balance. Climbers and rappellers who are properly belayed cannot fall more than a few feet before the belay rope stops them. Because climbers without a belay must **never** have their feet more than shoulder-height above the ground, they, too, should not fall far.

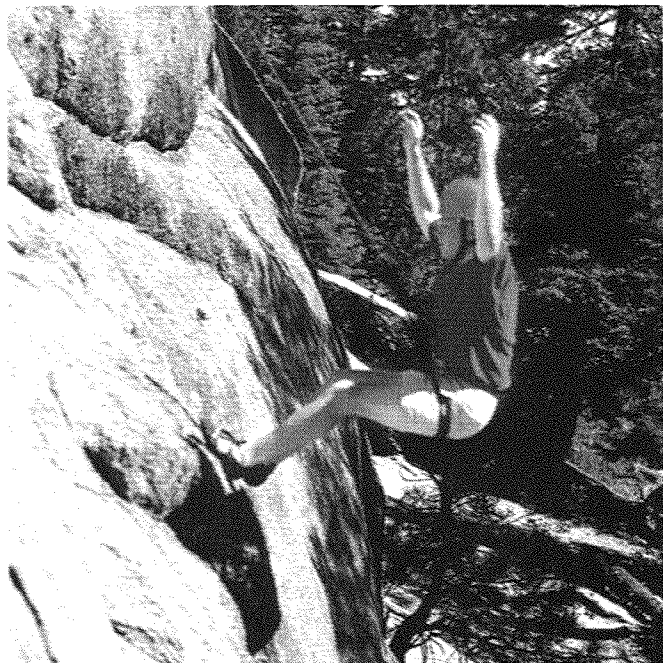

When you fall while climbing, the belay rope will stop you. If you bump against the rock, try to cushion the impact with your hands and feet, keeping your arms flexed rather than rigid. Then you can continue climbing, or your belayer can lower you to the ground.

## The Art of Falling

Don't let the possibility of falling scare you away from climbing and rappelling. With an alert belayer and a top-rope belay, a climber or rappeller should not fall more than a few inches. By accepting falling as a part of the sport, you can be ready for it when it does happen. These pointers will help.

- Stay relaxed. There is no need to panic.
- Maintain body control and face the rock.
- Keep your arms and legs bent and spread apart, catlike, to act as shock absorbers for cushioning the impact of bumping into the rock. Hold your head up and try to keep your chest away from the surface.

Proper rappelling position. Lean out from the rock face with your feet against the face and spread slightly, about shoulder width. Look down to see where you are going.

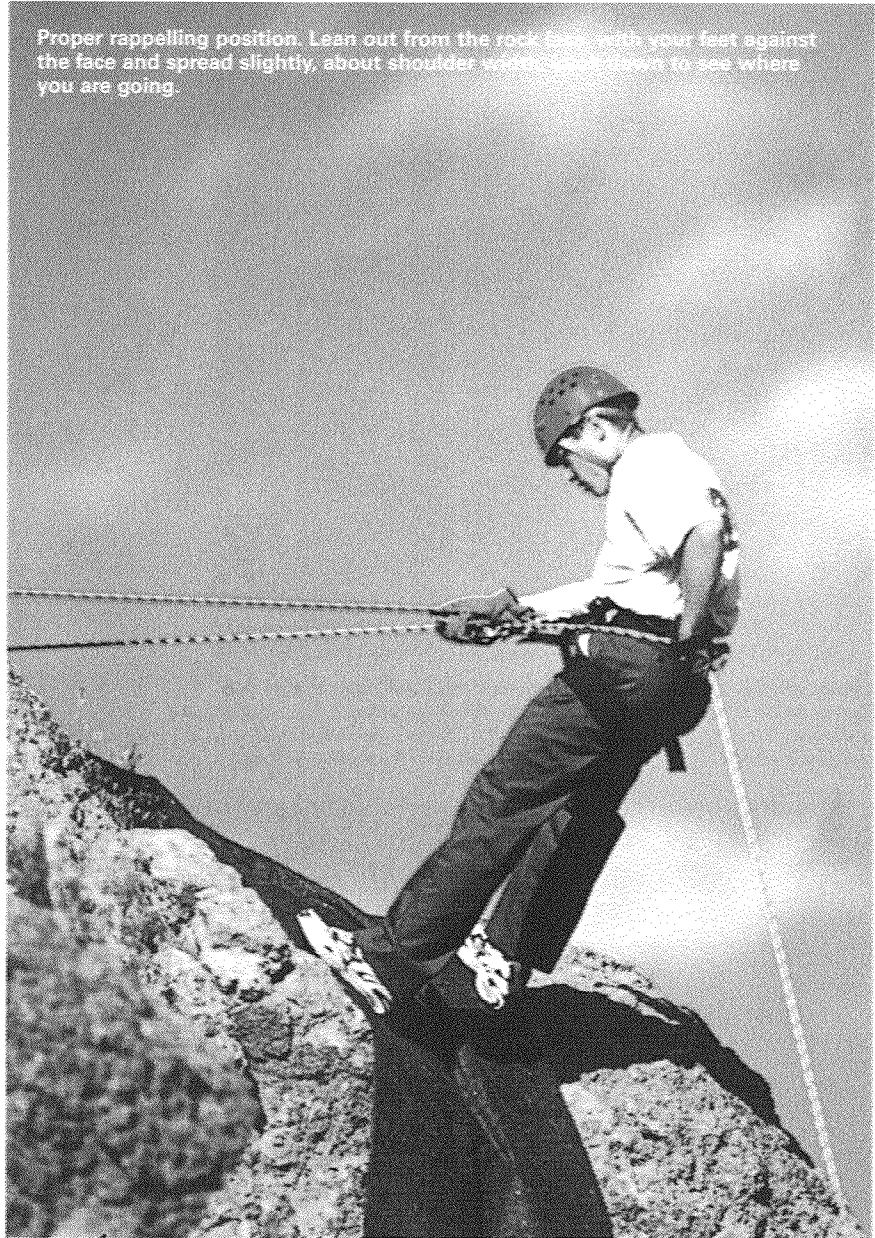

# Rappelling

Rappelling allows you to make controlled descents down rock faces that might have taken a long time to climb. Rappelling is often faster than climbing down. Rappelling should be done slowly to help prevent any chance of injury and to minimize damage to the rope. The friction created through the rappel device generates heat that, in excess, can burn (glaze) the rope and render it unsafe.

For rappelling, thread the *rappel rope* through hardware attached to your harness so that you can use friction to control the speed of your descent. One of the most popular ways to rappel is with a *figure-eight descending device*. Bend the rope through and around the device in such a way that you can apply friction to the rope, then clip the descending device to your harness with a locking carabiner (double-locking carabiner preferred) and you will be securely connected to the rappel rope. Tie the *belay rope* directly into your harness with a figure-eight follow-through knot backed up with a safety knot. Double-check all knots and the position of the rappel device.

**Attaching a figure eight device for a double rope rappel.** The rappel rope passes through a figure-eight descender so that a rappeller can use friction to control the speed of a descent. The small hole of the figure-eight device clips to a rappeller's harness with a locking carabiner.

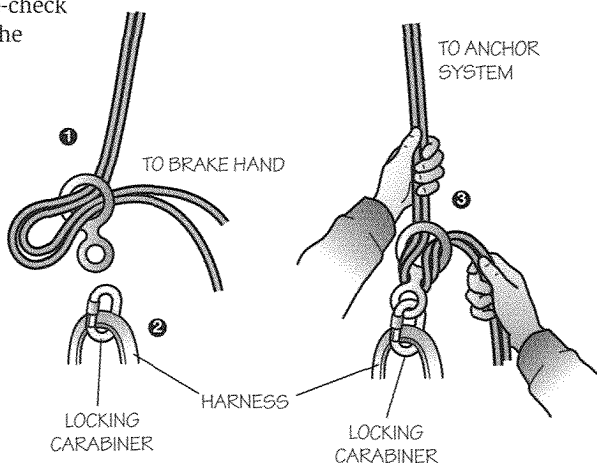

---

Be careful to not cross-load the carabiner when getting oriented to begin the rappel.

---



## Belaying a Rappeller

Belaying rappellers provides an important margin of safety, especially for those with beginning and intermediate skills. Anyone involved in BSA rappelling activities must be belayed. For the steps of belaying a rappeller, see the chapter in this pamphlet called "Harnesses, Anchors, and Belay Systems."

---

A safety knot tied near the lower end of the rappel rope can prevent a rappeller from sliding off the rope. Make the knot big enough that it cannot slip through a rappel device, and work out any slack.

---



Exchange verbal signals with your belayer, then back up to the edge of the cliff. Lean back as if you were sitting in a lawn chair. Keep your feet flat against the wall's face and your weight on your heels. Your feet should be about shoulder width apart. Walk down the wall backward, letting the rope slide slowly through your hands and the rappel device. Avoid lunging or lurching movements that might put stress on the anchor system. To stop, bend the rope behind your body so that no more rope slips through your brake hand.



If you slip while rappelling, hold the rope tightly and pull it to your hip on your brake-hand side. That should stop your descent immediately, but even if it doesn't, the belay rope will catch you within a few feet. Because your hands will be on the rappel rope, you won't be able to use them to cushion your impact against the rock. Instead, turn your body so that you bump into the rock with your shoulder and side rather than face first. Regain the rappel position and continue your descent.

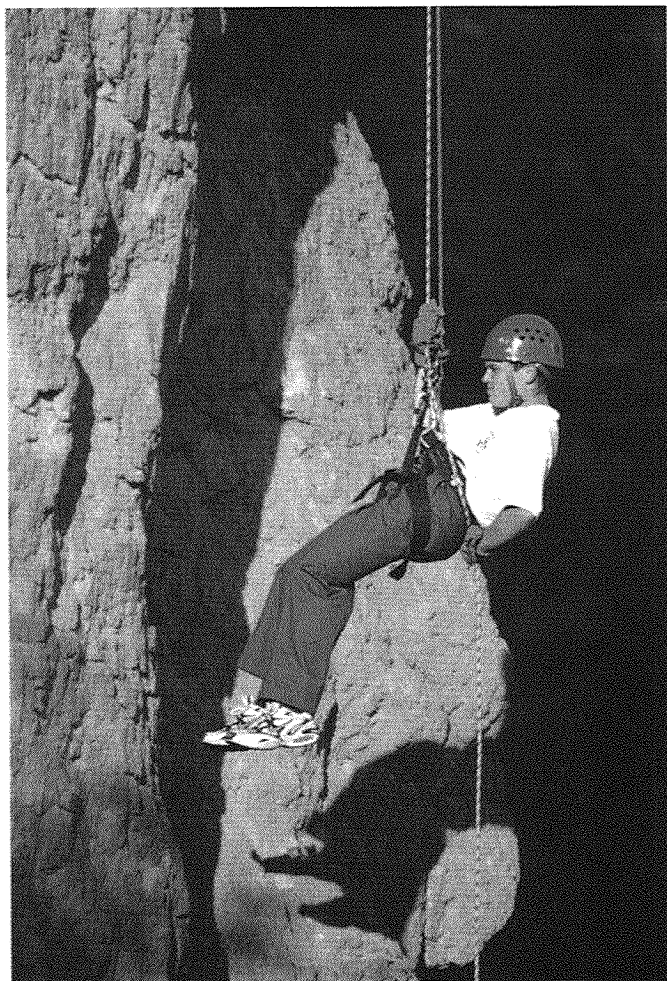

Rappel in a smooth, steady manner. Don't jump, bounce, or leap; that can put extra strain on the anchors, rope, and hardware.

## Climbing Ethics

---

Many climbing areas are in state and national parks. Be sure to obtain any permits that may be required to climb in those areas.

---

The ethics of rock climbing require that you do nothing to mark or damage the rock or to change the experience for other climbers. You may not, for instance, hammer or chip away at rock to improve a hold. Other climbers would be furious, and with good reason. Minimize the use of chalk, as it leaves its mark on the rock. Part of the sport is finding your holds, and chalk not only scars the face of the rock but also leaves a trail, which reduces the challenge of finding your route.

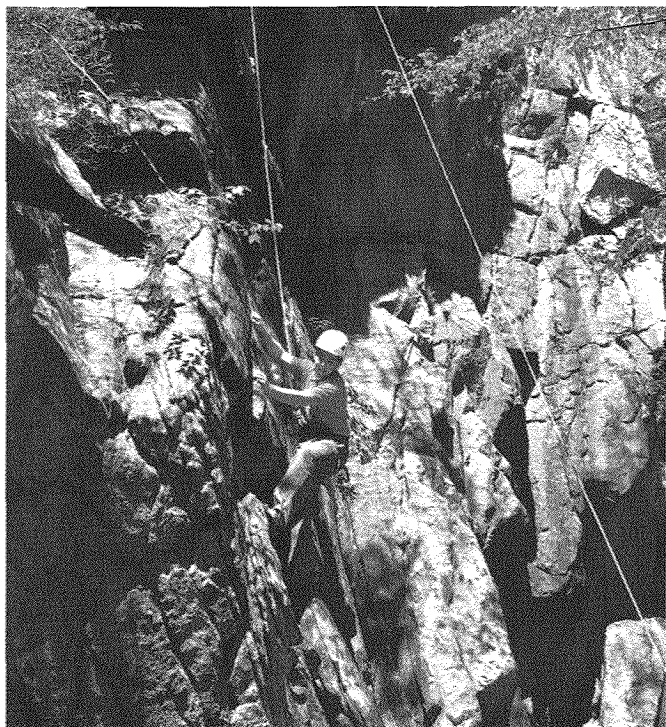

## Leave No Trace Climbing

As a Scout, you know about taking care of the environment and using no-trace methods in the outdoors. Most of the following guidelines will be familiar to you, because most of them apply to any outdoor activity, including climbing and rappelling.

- To reach climbing areas, walk on established trails, even if it takes a little longer than following a shortcut.
- Avoid harming grass, trees, and other vegetation at the climbing area.
- Do not bother nesting birds. Their eggs might not hatch if the nests are disturbed. Climbers make it a practice to avoid cliffs during the nesting season. The dates when particular cliffs are off-limits to climbers are usually published in climbing guidebooks for the area.
- Never scratch graffiti into rock surfaces or chip the rock to change natural handholds.
- Chalked-up holds can detract from the pleasure of an ascent for other climbers. On natural rock, avoid using chalk. If you must use it, use rock-colored or transparent chalk if possible and on the fingertips only. Securely close chalk bags so that chalk won't spill out.
- Pick up any trash you find, whether it is yours or someone else's. Put litter in your pockets or pack, and carry it out with you for proper disposal.

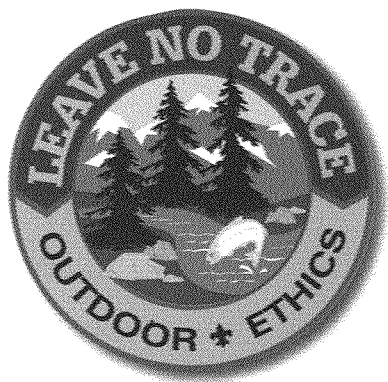

Before climbing anywhere on private property or public lands, you must get the landowner's or land manager's permission. Be careful to do no damage. It takes only one careless or inconsiderate climber to cause an area to be closed to all climbers.

# Climbing Terminology

**abseiling (or rappelling).** Descending by a controlled slide down a rope that is anchored at the top of a route. See *rappelling*.

**aid climbing.** Using rope and other gear to give the climber something to hang from or pull up on; using any means other than hands and feet to get up a climb. See *free climbing*.

**anchor.** Ropes, runners, and other pieces of equipment set up to secure a climber, rappeller, or belayer to an anchor point.

**anchor point.** A well-rooted tree, rock protrusion, properly installed bolt, properly placed pro, or other convenient location for attaching carabiners, runners, or rope for belay and rappel systems.

**ascending.** Moving upward.

**belay.** The protection provided a climber or rappeller tied to a belay rope. The rope is managed by a belayer in such a way that the fall of a climber or rappeller will be arrested almost immediately.

**belay device.** A piece of hardware used for belaying; it simplifies the process of locking the rope to stop the fall of a climber or rappeller. The most common belay devices are tube devices.

**belayer.** The person who manages the rope and is responsible for stopping the fall of a climber or rappeller.

**bight.** A bend in a rope. A bight is important for tying certain knots used for belaying, and for securing ropes into rappel or belay devices.

**bolt.** An artificial anchor point formed by driving a special bolt into a hole drilled into a *rock face*. This should only be done by a skilled climber. A carabiner may be clipped into the hanger attached to the bolt.

**bouldering.** Climbing on boulders or other steep faces without going more than shoulder-height off the ground. Boulderers are protected by spotters rather than a rope belay.

**carabiner.** A steel or aluminum ring with a spring-loaded gate. Carabiners are used to connect pieces of climbing equipment and to secure rope to webbing, anchor points, and protection devices.

**chimney.** A crack large enough to accommodate a climber's body.

**chimneying.** Ascending by pressing the hands and feet against opposite sides of a large crack.

**Climb On Safely.** The BSA's guidelines for effectively and safely managing unit climbing and rappelling activities.

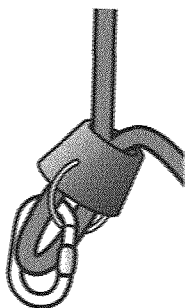

Belay device

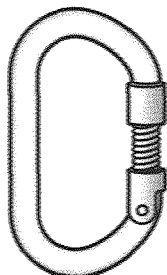

Carabiner

**climbing.** A challenging sport that always involves the skills of ascending and belaying or spotting, and may also include rappelling and bouldering.

**cling.** A handhold involving one or more fingers bent over a hold.

**counterbalance.** A combination hold that involves the entire body, requiring the climber to use position and weight distribution—for instance, applying pressure with the feet or hands in opposite directions—to make the most of minimal holds.

**descending.** Moving downward by rappelling or down-climbing.

**down-climbing.** Using hands and feet for balance while descending a moderate or steep face.

**dynamic rope.** Rope that stretches 6 percent to 10 percent to absorb the energy of a fall. Normally used for climbing.

**edge.** The brink of a ledge or a small horizontal hold on a rock face.

**edging.** Standing on a nub or narrow ledge of rock with the side of the climbing shoe.

**face.** A surface suitable for climbing, usually a natural rock formation. See *wall*.

**figure-eight descending device.** The hardware most often used by rappellers to control the speed of their descents.

**foothold.** A knob of rock, a crack, an edge, or some other feature of a climbing surface where a climber can place a foot while ascending or descending.

**free climbing.** Using only the hands and feet on natural features of the rock; rope and hardware are not used directly to help the climber scale a surface, but only for safety in case the climber falls. See *aid climbing*.

**handhold.** A knob of rock, a crack, a ledge, or some other feature of a climbing surface that a climber can hold onto while ascending or descending.

**hard fall.** An instance when a climber or rappeller falls far enough to place significant stress on the body, rope, webbing, or hardware. A hard fall will likely result in injury to the climber. Records of hard falls must be noted in the written histories of the rope and gear involved, and factored into equipment retirement decisions.

**harness.** Webbing either tied or commercially sewn to fit around the hips and legs. Harnesses allow climbers, rappellers, and belayers to attach themselves to belay systems and rappel ropes.

**jamming.** Placing a hand or foot into a crack and wedging it so that it will not slip out.

**kernmantle.** Strong, synthetic rope composed of a woven outer sheath surrounding an inner core. Kernmantle rope is the only rope that should be used for BSA climbing, rappelling, or belaying activities.

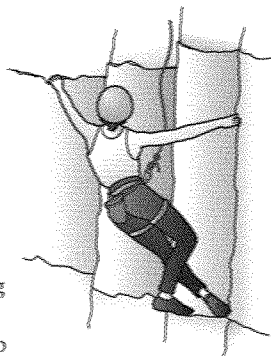

Counterbalancing

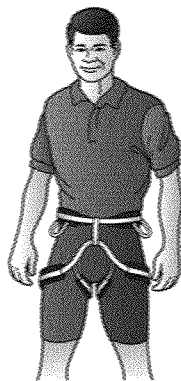

Harness

**kiloNewton.** A unit of measurement for determining the impact force and breaking strength of climbing ropes (1 kiloNewton = 224.8 pounds).

**lead climbing.** When climbers establish points of protection as they ascend by inserting chocks, nuts, or other hardware into cracks in the rock, and clipping the belay rope to them with carabiners, usually using quickdraws intended to keep the rope in line. This type of climbing may be practiced during BSA council and district activities only with a top-rope belay.

**Leave No Trace.** The BSA's methods and commitment to caring for the outdoors; the principles of Leave No Trace extend to climbing areas and the routes leading to them.

**lieback (layback).** A climbing hold accomplished by pulling against a crack or an edge with the hands while pressing on rock with the feet while maintaining three-point contact at all times.

**locking carabiner.** A carabiner fitted with a mechanism that can be screwed or set to hold the carabiner gate closed. A double-locking carabiner is preferred for BSA climbing and rappelling activities.

**mantle.** A climbing maneuver for hoisting oneself onto a ledge.

**mountaineering.** Climbing mountains. In addition to rock climbing ability, mountaineering may require the skills of route finding, wilderness camping, and ascending snow and ice.

**nose-over-toes.** A well-balanced position used to make descents on gentle slopes.

**pockets.** Holes in rock that may be used as holds.

**protection.** A piece of equipment used as an anchor point; sometimes shortened to "pro."

**protection system.** The rope, hardware, webbing, and anchors used together to belay a climber or rappeller.

**rappel device.** A piece of hardware such as the figure-eight descending device that helps rappellers control the speed of a rappel.

**rappelling.** Descending by a controlled slide down a rope that is anchored at the top of a route.

**rest step.** A way of settling the weight onto the skeletal system in order to allow muscles to recover during a climb.

**rock gym.** An indoor climbing facility.

**rope bag.** A bag or pack designed for stowing and carrying a climbing rope.

**rope drag.** Friction or resistance created when a rope runs over rock or through pieces of protection.

**rope stretch.** The amount of "give" in a climbing rope.

**runner (sling).** A loop of commercially prepared webbing used for various purposes including setting up anchors, placing protection, and connecting pieces of climbing equipment.

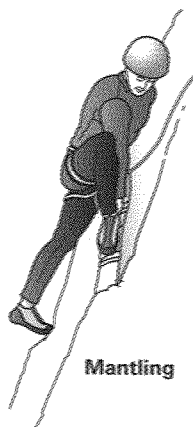

**Mantling**

**safety knot.** A knot tied in addition to the main knot to keep the main knot from untying or slipping. Also called a "backup" knot or "stopper" knot.

**sewing machine leg.** The shaking phenomenon sometimes experienced by a climber when muscles tire.

**slingshot belay.** A top-rope belay featuring a belayer on the ground. The rope runs from the belayer up to an anchor at the top of the climb, then down to the climber, forming the shape of a slingshot.

**smearing.** Pressing the sole of a climbing shoe against a surface in order to climb.

**spotter.** A person on the ground who provides protection to a boulderer to help prevent injury in case of a fall.

**static rope.** Rope with minimal stretch. Static kernmantle rope can be used for top-rope belays and most commonly for rappelling.

**sticht plate.** A simple belay device that, like all belay devices, relies on friction.

**tail.** The free end of a rope or piece of webbing after a knot has been tied. A safety knot is often tied in the tail to help protect the primary knot.

**three-point stance.** A stable position for a climber. One hand and both feet are on good holds on the rock, or two hands and one foot, freeing the other limb to move.

**top-ropeing.** Belaying a climber with an anchor at the top of a climb. The belayer may be anchored at the bottom of a climb (see *slingshot belay*), or at the top. All BSA climbing activities more than shoulder-height above the ground must be protected with a belay.

**traversing.** Moving sideways on a face without gaining or losing much elevation.

**tubular webbing.** Nylon straps used to rig anchors, to form seat harnesses, to make runners, and for other purposes.

**tying in.** Attaching a rope to a climber's harness.

**undercling.** A kind of hold with the palms facing up, usually under a rock formation.

**wall.** A vertical climbing surface, often found at climbing gyms and constructed outdoor climbing facilities. High rock faces are also known as walls.



**Undercling**

# Climbing Resources

## Scouting Literature

*Belay On; Boy Scout Handbook; Climb on Safely; Learn and Live Knot Cards*

With your parent's permission, visit the Boy Scouts of America's official retail website, [www.scoutshop.org](http://www.scoutshop.org), for a complete listing of all merit badge pamphlets and other helpful Scouting materials and supplies.

## Instruction and Guidebooks

- Allen, Linda B. *High Mountain Challenge: A Guide for Young Mountaineers*. AMC Books, 1989.
- Burbach, Matt. *Gym Climbing: Improve Technique, Movement, and Performance*. Mountaineers Books, 2018.
- Donahue, Topher and Craig Luebben. *Rock Climbing: Mastering Basic Skills*, 2nd ed. Mountaineers Books, 2014.
- Fawcett, Ron, et al. *The Climber's Handbook: Rock, Ice, Alpine, Expeditions*. Sierra Club, 1987.
- Lewis, S. Peter. *Climbing: From Gym to Crag, Building Skills for Real Rock*. Mountaineers Books, 2000.
- Linxweiler, Eric, and Mike Maude, eds. *Mountaineering: The Freedom of the Hills*, 9th ed. Mountaineers Books, 2017.
- Long, John. *How to Rock Climb!* Globe Pequot Press, 2010.
- Long, John, and Bob Gaines. *Climbing Anchors*. Falcon Guides, 2013.
- Loughman, Michael. *Learning to Rock Climb*. Random House, 1982.
- Luebben, Craig. *Knots for Climbers*. Falcon, 2011.
- Mellor, Don. *Rock Climbing: A Trailside Guide*. W. W. Norton, 2003.
- Roper, Steve, and Allen Steck. *Fifty Classic Climbs of North America*. Sierra Club, 1996.
- Sherman, John. *Better Bouldering*, 2nd ed. Falcon, 2012.
- Skinner, Todd, and John McMullen. *Modern Rock Climbing: Beyond the Basics*. ICS Books, 1993.
- Takeda, Pete. *Extreme Sports: Climb!* National Geographic, 2002.
- Toula, Tim. *Rock 'n' Road: An Atlas of North American Rock Climbing Areas*, 2nd ed. Falcon, 2003.



Voeller, Edward A. *Sport Climbing*.  
Capstone Books, 2000.

Wilkerson, James A., ed. *Medicine for  
Mountaineering and Other  
Wilderness Activities*, 6th ed.  
Mountaineers Books, 2010.

## History and Biography

Bonington, Chris. *Mountaineer: Thirty  
Years of Climbing on the World's  
Great Peaks*. Sierra Club, 1996.

Curran, Jim. *K2: Triumph and Tragedy*.  
Houghton Mifflin, 1987.

Fraser, Mary Ann. *On Top of the World:  
The Conquest of Mount Everest*.  
Henry Holt, 1991.

Jones, Chris. *Climbing in North America*.  
Mountaineers Books, 1997.

Krakauer, Jon. *Into Thin Air: A Personal  
Account of the Mount Everest  
Disaster*. Anchor Books, 1998.

MacDonald, Dougald, ed. *The Best of  
Rock and Ice: An Anthology*.  
Mountaineers Books, 1999.

Messner, Reinhold. *The Crystal Horizon:  
Everest—The First Solo Ascent*.  
Mountaineers Books, 1989.

Rosen, Mike. *The Conquest of Everest*.  
Bookwright Press, 1990.

Sherman, John. *Stone Crusade: A  
Historical Guide to Bouldering  
in America*. American Alpine  
Club, 1999.

Weihenmayer, Erik. *Touch the Top of  
the World: A Blind Man's Journey to  
Climb Farther Than the Eye Can See:  
My Story*. Plume, 2001.

Whittaker, Jim. *A Life on the Edge:  
Memoirs of Everest and Beyond*,  
50th anniversary edition.  
Mountaineers Books, 2013.

## Periodicals

### **Climbing Magazine**

5720 Flatiron Parkway  
Boulder, CO 80301

Telephone: 303-253-6412

Website: [www.climbing.com](http://www.climbing.com)

## Organizations and Online Resources

### **Mountain Project**

Website: [www.mountainproject.com](http://www.mountainproject.com)

## Acknowledgments

We appreciate staff members of the All Adventure climbing gym in Torrington, Connecticut, for allowing us to use their facilities to shoot many of the indoor climbing photos seen in this pamphlet. Thanks also to the Connecticut Rivers Council's Camp Mattatuck in Plymouth, Connecticut. Many of the outdoor tower photos were taken there, and we appreciate the use of the camp facilities.

The Boy Scouts of America is grateful to the men and women serving on the National Merit Badge Subcommittee for the improvements made in updating this pamphlet.

## Photo and Illustration Credits

Berg Adventures, courtesy—page 16

Shutterstock.com, courtesy—pages 30 (*rattlesnake*, ©JayPierstorff) and 36 (©Jhaz Photography)

U.S. Department of Agriculture, Agricultural Research Service/Scott Bauer, courtesy—page 29 (*top*)

All other photos and illustrations not mentioned above are the property of or are protected by the Boy Scouts of America.

John McDearmon—all illustrations on pages 14–15, 30, 39, 41, 43, 45–47, 51–57, 59–60, 62–65, 71, 74–78, 80, 85, and 90–93

## MERIT BADGE LIBRARY

Though intended as an aid to Boy Scouts, and qualified Venturers and Sea Scouts in meeting merit badge requirements, these pamphlets are of general interest and are made available by many schools and public libraries. The latest revision date of each pamphlet might not correspond with the copyright date shown below, because this list is corrected only once a year, in January. Any number of merit badge pamphlets may be revised throughout the year; others are simply reprinted until a revision becomes necessary.

If a Scout has already started working on a merit badge when a new edition for that pamphlet is introduced, *they may continue to use the same merit badge pamphlet to earn the badge and fulfill the requirements therein.* In other words, the Scout need not start over again with the new pamphlet and possibly revised requirements.

Merit Badge Pamphlet	Year	Merit Badge Pamphlet	Year	Merit Badge Pamphlet	Year
American Business	2013	Family Life	2016	Plant Science	2018
American Cultures	2013	Farm Mechanics	2017	Plumbing	2012
American Heritage	2013	Fingerprinting	2014	Pottery	2008
American Labor	2018	Fire Safety	2016	Programming	2013
Animal Science	2014	First Aid	2015	Public Health	2017
Animation	2015	Fish and Wildlife		Public Speaking	2013
Archaeology	2017	Management	2014	Pulp and Paper	2013
Archery	2015	Fishing	2013	Radio	2017
Architecture and Landscape Architecture	2014	Fly-Fishing	2014	Railroading	2015
Art	2013	Forestry	2015	Reading	2013
Astronomy	2016	Game Design	2013	Reptile and Amphibian Study	2018
Athletics	2016	Gardening	2013	Rifle Shooting	2012
Automotive Maintenance	2017	Genealogy	2013	Robotics	2016
Aviation	2014	Geocaching	2016	Rowing	2014
Backpacking	2016	Geology	2016	Safety	2016
Basketry	2017	Golf	2012	Salesmanship	2013
Bird Study	2017	Graphic Arts	2013	Scholarship	2014
Bugling (see Music)		Hiking	2016	Scouting Heritage	2017
Camping	2018	Home Repairs	2012	Scuba Diving	2009
Canoeing	2014	Horsemanship	2013	Sculpture	2014
Chemistry	2018	Indian Lore	2008	Search and Rescue	2018
Chess	2016	Insect Study	2018	Shotgun Shooting	2013
Citizenship in the Community	2015	Inventing	2016	Signs, Signals, and Codes	2015
Citizenship in the Nation	2014	Journalism	2017	Skating	2015
Citizenship in the World	2015	Kayaking	2016	Small-Boat Sailing	2016
Climbing	2011	Landscape Architecture (see Architecture)		Snow Sports	2017
Coin Collecting	2017	Law	2011	Soil and Water Conservation	2016
Collections	2013	Leatherwork	2017	Space Exploration	2016
Communication	2013	Lifesaving	2017	Sports	2012
Composite Materials	2012	Mammal Study	2014	Stamp Collecting	2013
Cooking	2014	Medicine	2012	Surveying	2004
Crime Prevention	2012	Metalwork	2012	Sustainability	2013
Cycling	2017	Mining in Society	2010	Swimming	2014
Dentistry	2016	Model Design and Building	2014	Textile	2014
Digital Technology	2014	Motorboating	2015	Theater	2014
Disabilities Awareness	2016	Moviemaking	2013	Traffic Safety	2016
Dog Care	2016	Music and Bugling	2013	Truck Transportation	2013
Drafting	2013	Nature	2014	Veterinary Medicine	2015
Electricity	2013	Nuclear Science	2017	Water Sports	2015
Electronics	2014	Oceanography	2012	Weather	2013
Emergency Preparedness	2015	Orienteering	2016	Welding	2016
Energy	2014	Painting	2016	Whitewater	2005
Engineering	2016	Personal Fitness	2016	Wilderness Survival	2012
Entrepreneurship	2013	Personal Management	2015	Wood Carving	2016
Environmental Science	2015	Pets	2013	Woodwork	2011
Exploration	2016	Photography	2016		
		Pioneering	2017		

## BOY SCOUTS OF AMERICA • SUPPLY GROUP

### NATIONAL DISTRIBUTION CENTER

2109 Westinghouse Boulevard  
P.O. Box 7143  
Charlotte, NC 28241-7143

To place an order,  
call customer service  
toll-free 800-323-0736  
or go to  
[www.scoutshop.org](http://www.scoutshop.org)

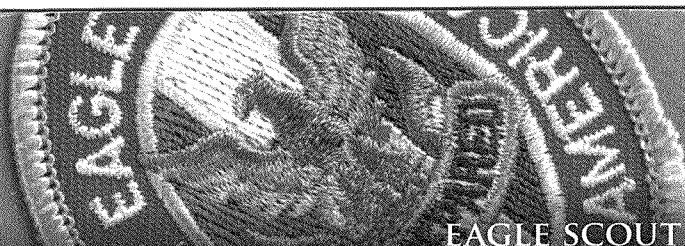

EAGLE SCOUT

THE SUPPLY GROUP IS  
READY TO BE A PARTN  
ON YOUR TRAIL TO  
EAGLE THROUGH HIG  
ADVENTURE. THE  
ADVENTURE IS YOURS  
AND WE ARE READY  
WITH THE GEAR YOU  
WILL NEED. YOU CAN  
DEPEND ON THE LATE  
IN LIGHTWEIGHT,  
DURABLE, QUALITY  
GEAR THAT WILL  
MEET AND SURPASS  
YOUR TOUGHEST  
REQUIREMENTS.



THE SUMMIT



FLORIDA SEA BASE

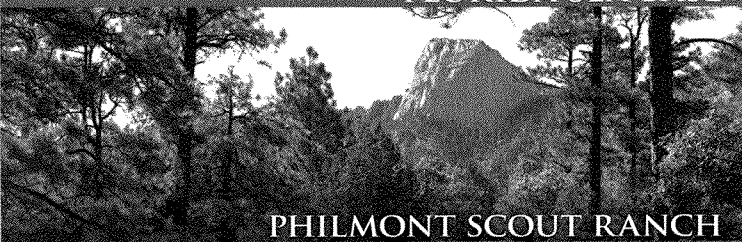

PHILMONT SCOUT RANCH

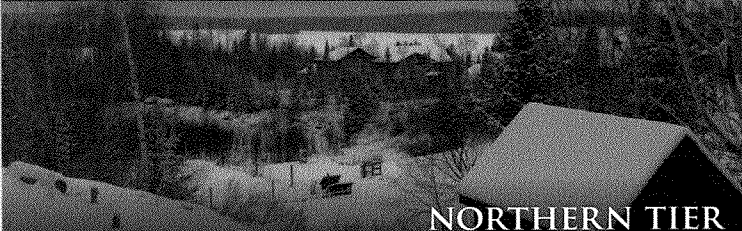

NORTHERN TIER



[WWW.SCOUTSHOP.OF](http://WWW.SCOUTSHOP.OF)

SKU 649739



35873 2019 Print

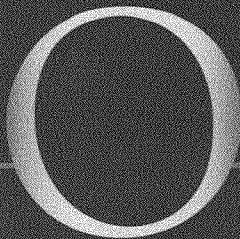

ON THE ROAD TO  
HIGH ADVENTURE



Certified Source  
[www.sfi-program.org](http://www.sfi-program.org)  
SFI-00358