

MERIT BADGE SERIES

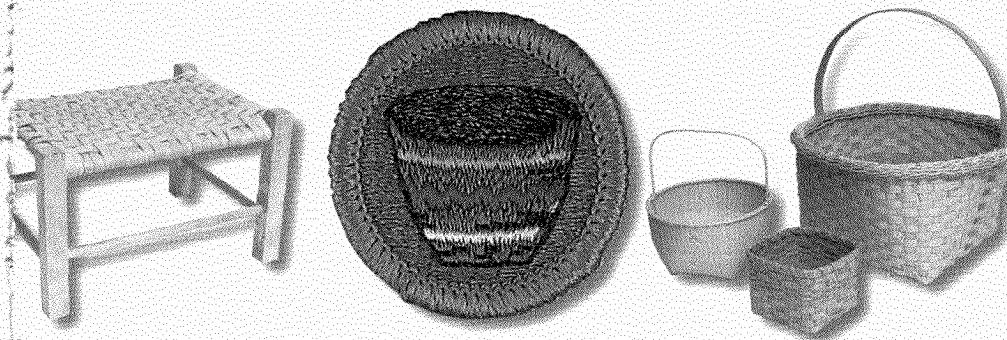

BASKETRY

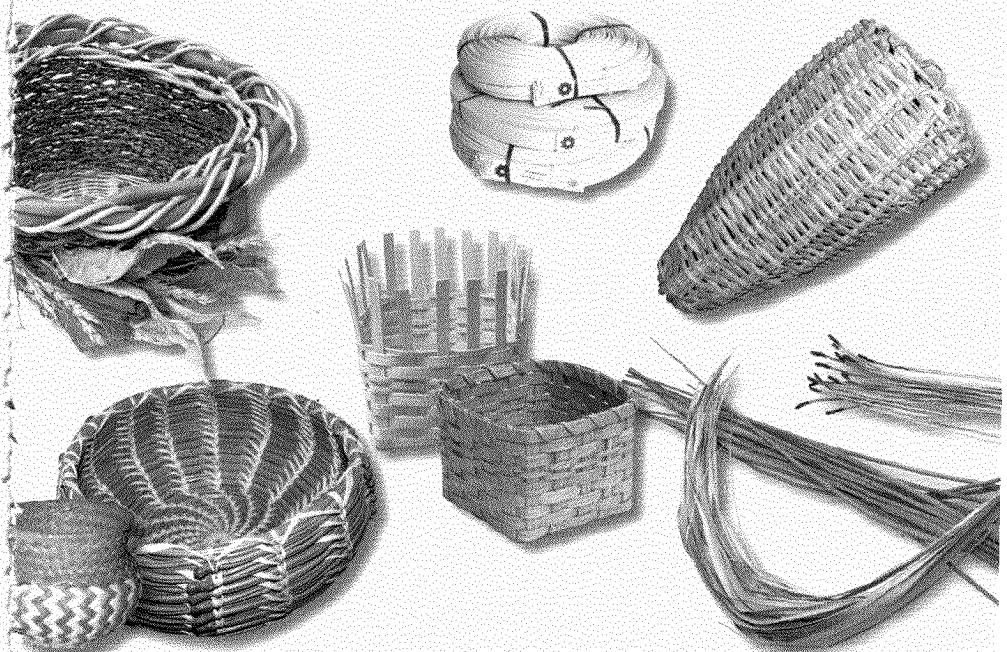

BOY SCOUTS OF AMERICA



How to Use This Pamphlet

The secret to successfully earning a merit badge is for you to use both the pamphlet and the suggestions of your counselor.

Your counselor can be as important to you as a coach is to an athlete. Use all of the resources your counselor can make available to you. This may be the best chance you will have to learn about this particular subject. Make it count.

If you or your counselor feels that any information in this pamphlet is incorrect, please let us know. Please state your source of information.

Merit badge pamphlets are reprinted annually and requirements updated regularly. Your suggestions for improvement are welcome.

Who Pays for This Pamphlet?

This merit badge pamphlet is one in a series of more than 100 covering all kinds of hobby and career subjects. It is made available for you to buy as a service of the national and local councils, Boy Scouts of America. The costs of the development, writing, and editing of the merit badge pamphlets are paid for by the Boy Scouts of America in order to bring you the best book at a reasonable price.

Send comments along with a brief statement about yourself to
Pilots and Program Development, S272

Boy Scouts of America • 1325 West Walnut Hill Lane • Irving, TX 75038
If you prefer, you may send your comments to merit.badge@Scouting.org.

BOY SCOUTS OF AMERICA
MERIT BADGE SERIES

BASKETRY

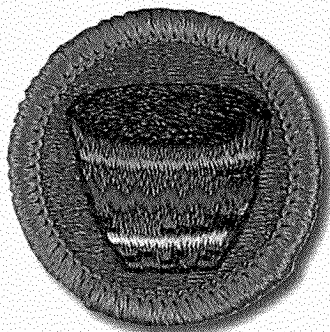

"Enhancing our youths' competitive edge through merit badges"



BOY SCOUTS OF AMERICA®

Requirements

1. Do the following:
 - a. Explain to your counselor the hazards you are most likely to encounter while using basketry tools and materials, and what you should do to anticipate, help prevent, mitigate, and respond to these hazards.
 - b. Discuss the prevention of and first-aid treatment for injuries, including cuts, scratches, and scrapes, that could occur while working with basketry tools and materials.
2. Do the following:
 - a. Show your counselor that you are able to identify each of the following types of baskets: plaited, coiled, ribbed, and wicker.
 - b. Describe three different types of weaves to your counselor.
3. Plan and weave EACH of the following projects:
 - a. A square basket
 - b. A round basket
 - c. A campstool seat

Contents

Introduction	5
Beginning to Weave	7
Basketry Projects	15
Square Basket	16
Round Basket	25
Campstool Seat	33
American Indian Basketry	39
Basketry Terms	44
Basketry Resources	46



Introduction

No matter what part of the world your ancestors came from, woven baskets were part of their lives. Long before the invention of metal buckets, plastic containers, backpacks with built-in water bladders, and nylon duffel bags, your ancestors made baskets to carry and store water, food, and valuables.

Throughout recorded history, people all over the world have gathered native fibers, limbs, and vines to make baskets, woven mats, sandals, bedding, and furniture. They devoted considerable time and traveled long distances to find and harvest specific plants, taking great care to ensure that the grasses, plants, bushes, trees, and vines would regrow each year. After the harvest, these ancient peoples worked diligently to strip, peel, shave, and cut the materials into various sizes for weaving. Basket making and weaving were important even before the advent of clay pottery in ancient times.

Today, basketry is a practical art. A handmade basket reflects the unique techniques of the artist who created it, so each work can become a one-of-a-kind article.

Basketry is a handy skill for a Scout. A basket can be a sturdy companion on campouts, carrying clothes snugly and efficiently, holding potatoes and corn for roasting over a campfire, or carrying the day's fishing catch back to camp for dinner. Baskets and basket-weaving projects also make great gifts for family and friends.

Imagination can be one of the most useful basketry tools, whether you create a basket for its usefulness or simply for its beauty. As you complete the required projects for the Basketry merit badge, remember that while the interesting variations you experiment with might not turn out as you like, these unique qualities could be the features that distinguish your basket from the rest!

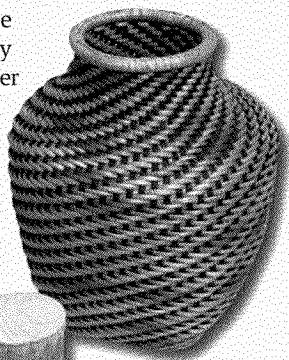
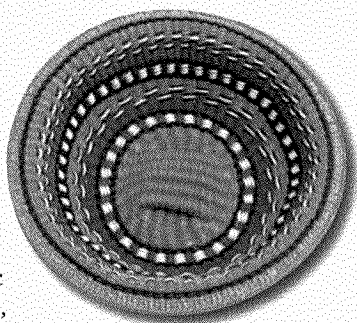



Beginning to Weave

The projects needed to complete the Basketry merit badge were designed to increase your weaving skills. Traditional styles of basket weaving are perhaps as old as the art itself, and the basic steps are easy to learn. This section will give you some tips to help you understand the fundamentals.

Note: The instructions and photos in this pamphlet describe projects from a right-handed person's viewpoint. If you are left-handed, you may adjust the steps so that you are more comfortable.

Safety Issues

You can use a pocketknife to cut willow or whatever natural materials you can gather to make a basket. Knives must be handled carefully to prevent injury. When using a pocketknife, always cut away from your body.

When removing the branches or shoots from a plant, brace the plant with your hand and cut with a diagonal slant to encourage the plant's growth to return. Keep your bracing hand opposite the direction of the cut. Remember, a knife is not a toy. Use caution when cutting your materials.

If minor cuts and scrapes occur, treat them by properly cleaning and dressing the wound. For wounds that are deep or that bleed heavily, control the bleeding by applying direct pressure to the wound with a sterile or clean dressing. If necessary, treat the victim for shock. Get medical help immediately. Reviewing the *First Aid* merit badge pamphlet will help you be prepared in case of injury.

Basketry is not a dangerous hobby, but being mindful of safety issues is always important. Move cautiously while you work, and think before you act.

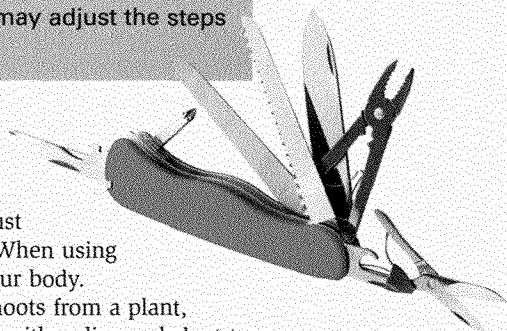

Safety Checklist

Review this safety checklist with a parent before beginning a basketry project.

- When cutting materials, focus all your attention on the task at hand.
- Keep materials and workspace well-organized by picking up cut reed from the floor as you go so that others do not slip or trip on the clippings.
- Never play in space devoted to craft projects.
- When walking around the craft area, point scissors and other sharp objects downward and be mindful of others.
- Keep tools sharp and free from rust and dirt.
- Store tools in a safe place and away from children.
- Knives and scissors should never be thrown.

Prevention goes hand in hand with mitigation, which means “to lessen in force or intensity” and “to make less severe.” By taking precautions to manage risk and the possibility of injury, you can be prepared to anticipate, help prevent, mitigate, and respond to just about any incident that might happen while working with basketry tools and materials.

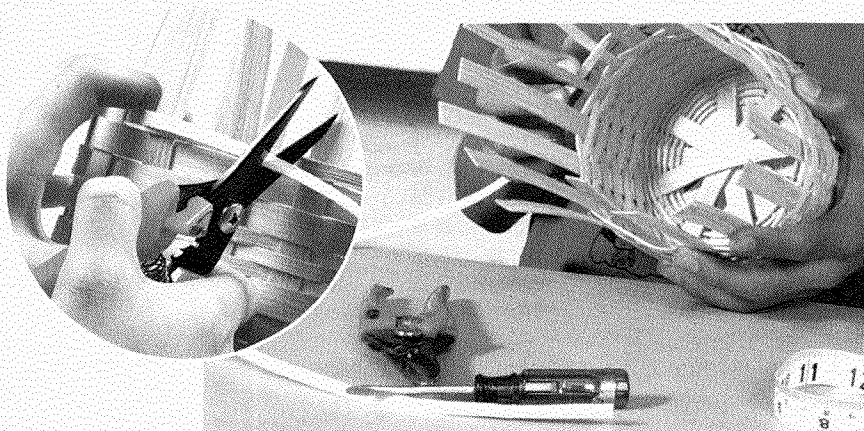

Point scissors and pliers away from your body when working with reed. Keep your bracing hand away from the path of the scissors.

What Is Reed?

Reed is the staple material of basket weavers and is the material you most likely will use to create the three required projects for the Basketry merit badge because it is easy to work with. Basket reed is produced from the core of a thorny palm called *rattan*, which is found in rainforest areas in South China, Australia, Fiji, West Africa, and Madagascar. Rattan grows like a vine and is harvested for commercial use mostly from the jungles of Indonesia and Southeast Asia. Factories process the reed into various sizes and shapes.

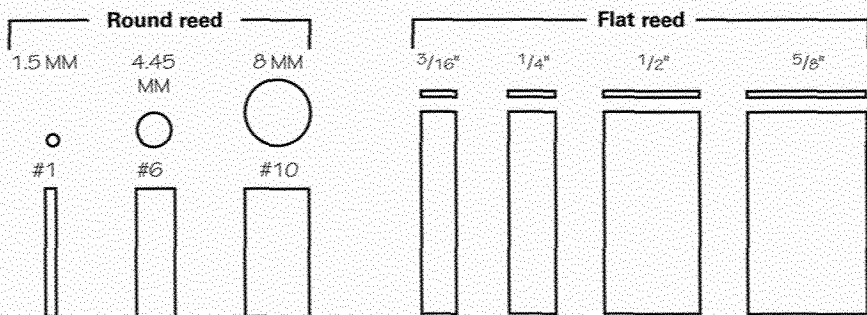

Flat reed comes in widths measured in fractions of inches: for example, $\frac{3}{16}$ inch, $\frac{1}{4}$ inch, $\frac{1}{2}$ inch, $\frac{5}{8}$ inch. Round reed is measured in numbered sizes, with the smallest numbers signifying the smallest diameters. Round reed is measured by its diameter in millimeters. Round reed #1 is very narrow, whereas #6 is fairly large. Anything larger than #10 usually is used for making furniture.

Flat reed has a "right" side and a "wrong" side, and the right side is always woven so that it is on the outside of the basket. Even though the right side is smoother, it is not always easy to determine which side is which. To find out, bend a wet piece of the reed into a U shape, being careful not to crease or crack the reed. If the reed's fibers splinter, the wrong side is out.

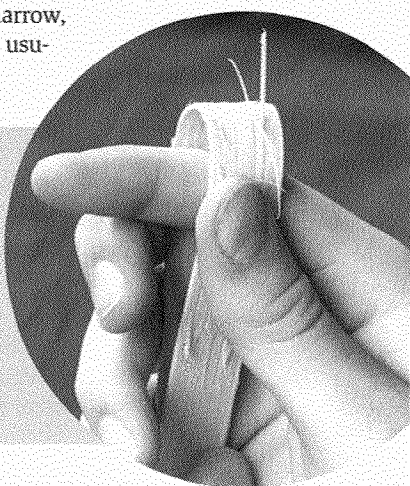

Types of Weaves

The following are common weaves used in this pamphlet.

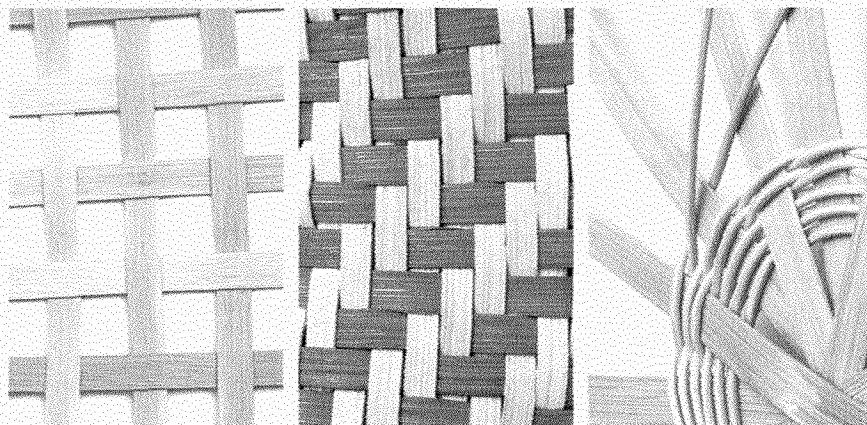

Plain weave

Twill weave

Twining

Plain Weave. Sometimes called over-under weave, the *plain weave* is done with rigid *stakes* or spokes, and weavers that wrap around the stakes in an over-one, under-one pattern. Spokes and stakes usually are more rigid and thicker reed than weavers.

Continuous weave looks much the same as plain weave, but it is woven with a different technique.

Continuous Weave. This weave is created over an odd number of stakes. It is not done one row at a time, but continuously from beginning to end, with additional weavers added when more length is needed.

Twill Weave. This method of weaving involves the weaver passing over two or more stakes and under two or more stakes at a time.

Twining. This weave, sometimes called *pairing*, involves two weavers, each alternately twisting over and under consecutive spokes.

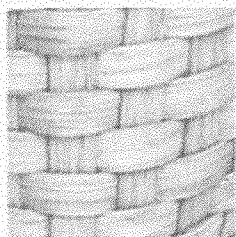

Plaited baskets



Types of Baskets

Different baskets may look a lot alike, but you will begin to see subtle differences as you learn more about weaving. *Plaited* baskets are created with flat strips of reed passing over and under flat stakes, giving the basket an interwoven look.

Ribbed baskets feature round or oval reed used to create a sturdy skeleton. Flat or round reed is woven around the skeleton to create the basket. Ribbed baskets are used to carry fragile items, such as eggs, that need to be cradled to prevent breakage.

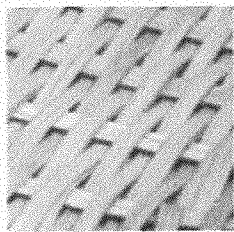

Ribbed baskets



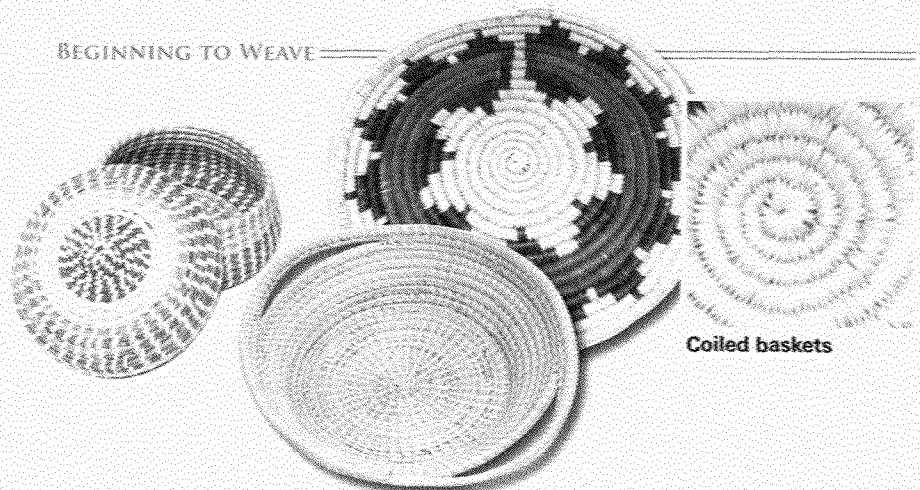

Coiled baskets

Coiled baskets have no skeleton, or frame. An inner core of natural material, such as pine needles, is wrapped solidly with a soft, flexible material such as sinew. The coils are stacked and sewn together in horizontal rows. Coiled baskets are far more pliable than other types and are just as strong and durable. Some traditional baskets created using this technique were so tightly coiled that they could hold water and were used for cooking food.

Wicker baskets, popularly used for picnic baskets, fishing creels, and hampers, use round reed or any round, flexible material such as willow that can be interwoven in a rigid framework.

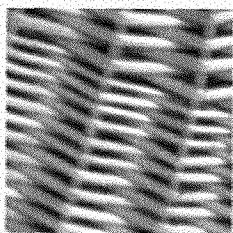

Wicker baskets



Weaving Tips

Work with wet reed and cane. Basketry materials are too brittle to be woven when they are dry. Reed and cane soaked in water for three to five minutes becomes flexible and easy to use. Do not leave the weaving material in the water for long periods, though, because it might get slimy!

Avoid mildew. You will be working with damp materials, so don't set your half-finished basket down on a wet towel or wet surface. Mildew is much easier to prevent than it is to clean. If your reed does mildew, soak it in a mild bleach-water solution or dab it with a bleach-soaked cotton swab, then leave it in the sun to dry, and it might come clean again. Do not use bleach on colored reed.

Store your materials properly. Brown paper bags or cardboard boxes are good choices for storage, or you could suspend different sizes of reed from hooks. Hot and dry air or wet and humid conditions can damage the reed. Never store reed in plastic containers unless it is completely dry.

Use spring-type clothespins. These little gadgets are not just for laundry anymore! They help keep weavers secure and the tension correct as you begin a project. Clothespins can be used to hold the corners of a square basket to help give it some shape. They also can anchor the inside and outside rims at the top of the basket when you are almost finished; you can release them one at a time as you lash the *rim* to the basket.

Correct your mistakes. Whenever your weaving does not look right—for example, if your plain weave suddenly has an over-over or under-under pattern—you have miswoven the current or previous row. Unweave along the row until you find a break in the pattern, then resume weaving with the correct pattern.

Keep consistent tension and pack the rows as you go. Keeping proper tension and *packing* the rows are separate functions that work together. The key is to keep even tension on the weaver as you weave around each stake. Pulling the weaver too tightly will cause the stakes to lean inward. Weaving too loosely will keep the weaver from lying flat against the stakes, resulting in a loose, lumpy basket. To weave a basket with even sides, pack each row firmly against the previous row—without any spaces between rows of weaving. Check frequently to ensure that all stakes are equally spaced. To pack down the rows as you slide them together, fit a small screwdriver or other packing tool between the stakes and apply downward pressure on the weaver.

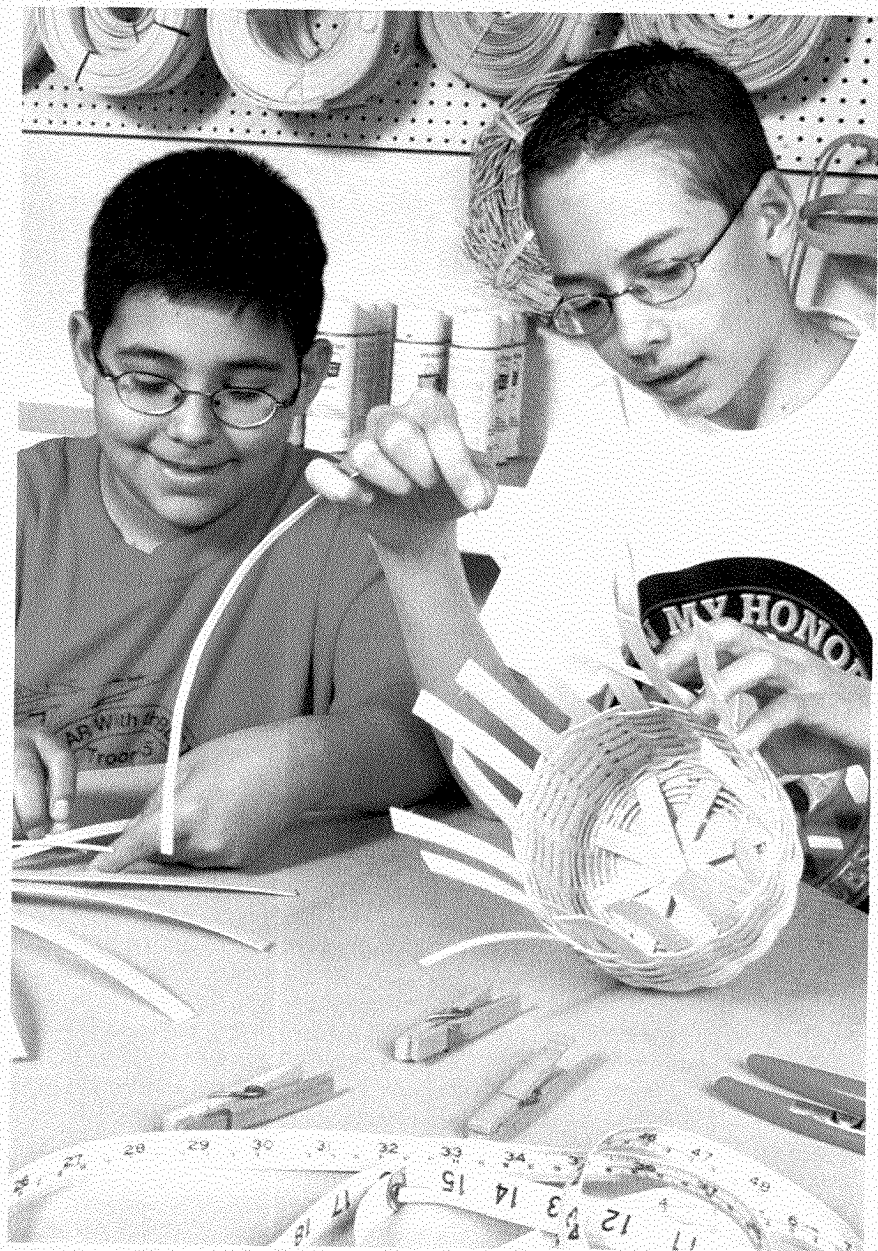

Basketry Projects

Beginning weavers should start with a simple project and build on their skill by trying projects of increased difficulty. The following projects can be used to meet the merit badge requirements, but any qualifying project will do.

Materials for Three Projects

To earn the Basketry merit badge, you must weave a square basket, a round basket, and a campstool seat. If you choose to do the three projects described in this pamphlet, you can make an economical choice for your materials by purchasing all the reed at once and cutting the lengths needed as you work on each project. You will need:

- A 1-pound coil of 1/2-inch flat reed
- About 64 feet of 1/4-inch flat reed
- About 25 feet of #3 round reed

When preparing the weaving materials, uncoil the reed and set aside the longest lengths of 1/2-inch flat reed to use in weaving the campstool seat.* Then cut the longest lengths for the baskets to help conserve the coil.

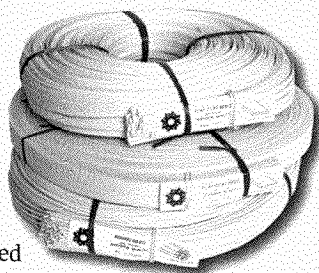

*If you have purchased a campstool kit, you may disregard this step.

For your convenience, the BSA National Distribution Center has prepackaged kits available for the square basket, round basket, and campstool seat featured in this pamphlet.

National Distribution Center
Boy Scouts of America
P.O. Box 7143
Charlotte, NC 28241-7143
Toll-free telephone: 800-323-0736
Website: <http://www.scoutshop.org>



Basic Tools Needed

- Pencil
- Tape measure
- Scissors
- Small screwdriver or packing tool
- Spray bottle
- Container for water
- An old terrycloth towel
- Clothespins
- Fine sandpaper
- Masking tape or cable ties
- Small needle-nose pliers
- Office stapler with staples (for campstool only)

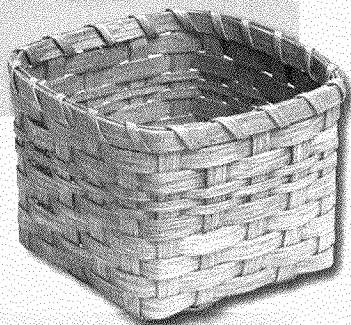
**Square Basket**

This project works well for the beginner. It will use a plain weave (over-under) and should take about two hours to complete.

Basket Dimensions

Base: 5 by 5 inches

Height: 5 inches

Circumference: about 23 inches

Materials Needed

- 42 feet of 1/2-inch flat reed
- 22 feet of 1/4-inch flat reed
- 25 inches of #3 round reed

Preparation

Cut the following pieces of reed before you start to weave.

Stakes

Cut ten 20-inch stakes from 1/2-inch flat reed

Locking weaver

Cut one 27-inch locking weaver from 1/4-inch flat reed

Weavers

Cut seven 27-inch weavers from 1/2-inch flat reed

Cut four 27-inch weavers from 1/4-inch flat reed

Rims

Cut two 27-inch rims from 1/2-inch flat reed

Rim filler

Cut one 25-inch rim filler from #3 round reed

Lasher

Cut one 75-inch lasher from 1/4-inch flat reed

Weave the Base

Step 1—Soak the stakes and the locking weaver in water for three to five minutes. Remove the stakes from the water, and blot each with a towel.

Step 2—With a pencil, lightly mark the center of all 10 stakes on the wrong side of the reed.

Step 3—Begin the base by laying five stakes, horizontally and wrong side up, about $\frac{5}{8}$ inch apart. Line up the center marks.

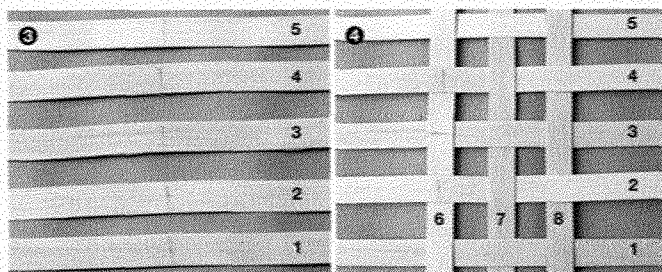
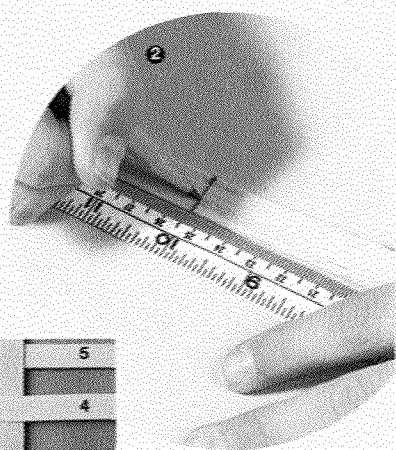

Step 4—Weave stake 6, wrong side up, directly up the center of the horizontal stakes, along the center marks. Begin weaving from the bottom, *over* the first stake, *under* the second, *over*, *under*, etc.

Step 5—Weave stake 7 to the right of 6. This weave is *under*, *over*, *under*, *over*, *under*, *over*, opposite of the previous stake.

Step 6—Weave stake 8 to the right of stake 7. The weave is *over*, *under*, *over*, *under*, *over*.

Step 7—Weave stakes 9 and 10 to the left of the center stake in the same manner as 7 and 8.

Step 8—Adjust the stakes so that they are evenly spaced in all directions and the woven base measures 5 by 5 inches. Draw a light pencil line on each side of all four corners to help you align the corner stakes if they are moved.

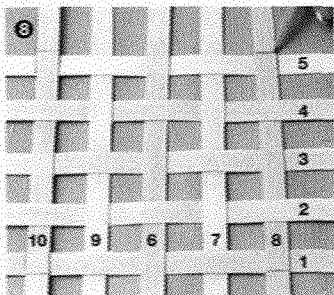

You always will weave clockwise if you are right-handed; you will weave counter-clockwise if you are left-handed.

Step 9—Place the $\frac{1}{4}$ -inch flat locking weaver (9a), wrong side facing up, on top of the center stake, along the outside edge of the base. Weave over stake 6, under 7, and over 8. Turn the corner (9b) by folding the reed 90 degrees so that it heads right side up, down the right side of the base. Weave under stake 5 and over stake 4.

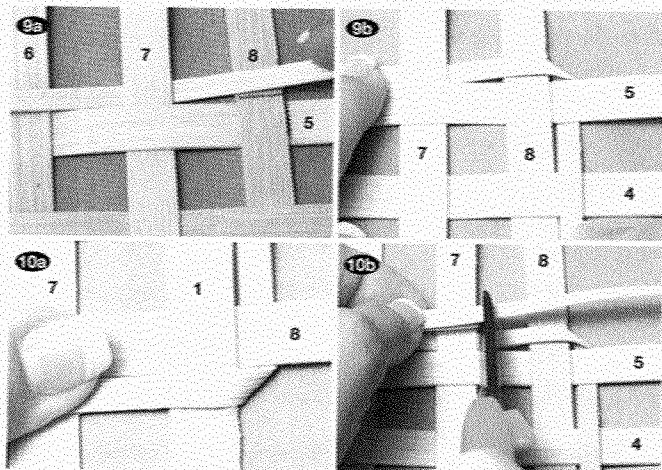

Step 10—Continue to weave under and over to the next corner, again folding the weaver on a 90-degree angle as you turn the corner (10a). The wrong side is now facing up. Continue around the next two corners in the same manner and then back to the center stake. Lay the end of the weaver directly on top of the beginning weaver. Make sure that the locking row is packed tightly against the edge of the woven base. Cut the excess weaving material even with the outside edge of stake 7 (10b). Be careful not to cut the weaver too short. Tuck the end of the weaver behind stake 7. This completes the locking row.

Step 11—Soak all 11 weavers in water for three to five minutes.

Step 12—Mist the stakes with water to dampen them, then upset each stake, one at a time, by bending it over the locking row. Be careful not to bend the stake past the locking row. Do not worry if the stakes crack.

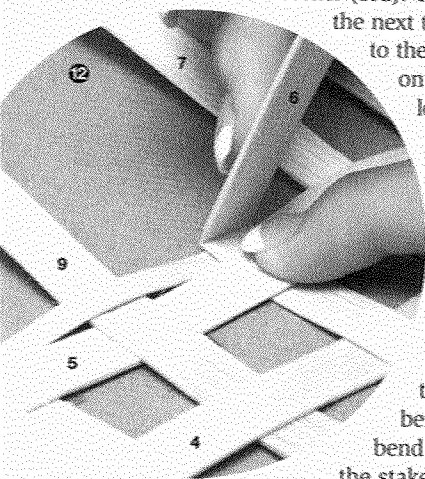

Weaving the Sides

You are now ready to begin weaving the sides of the basket. Keep in mind that you have been working on the inside of the basket with all the wrong side of the reed facing up. You are now going to work on the outside of the basket. As you work, remember that the right side of the reed needs to be on the outside of the basket.

Step 1: Begin row 1—Choose a center stake that will allow you to begin weaving opposite of the locking row. Use clothespins to secure a 1/2-inch flat weaver to the front side of that stake. Make sure the right side of the weaver faces you.

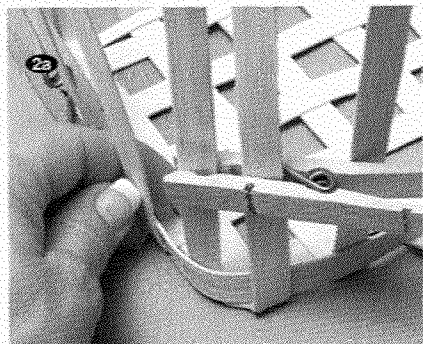
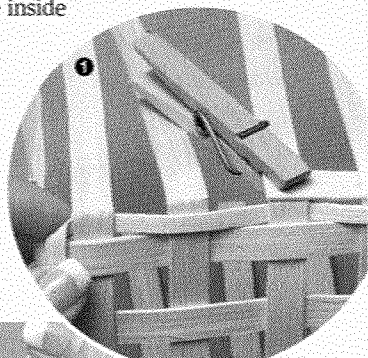

Step 2—Begin weaving *under* and over around the sides of the basket. As you weave around a corner, use clothespins near the base to secure the two corner stakes (2a). This helps to give the basket some shape. When you return to the beginning, remove the first clothespin and overlap the beginning of the weaver by four stakes. Cut off any excess weaver and tuck it behind the last stake (2b). Replace the first clothespin to hold the weaver in place.

Step 3—Check your weaving. Also check the tension in the weave, tightening the weaver if it is too loose. Make sure that the spacing between the stakes is the same as in the base and that the first row of weaving is packed right next to the locking row.

Hint: It is helpful to use clothespins to help keep the weaver and the corner stakes in place for the first two or three rows only. After the third row the basket sides should stand upright on their own.

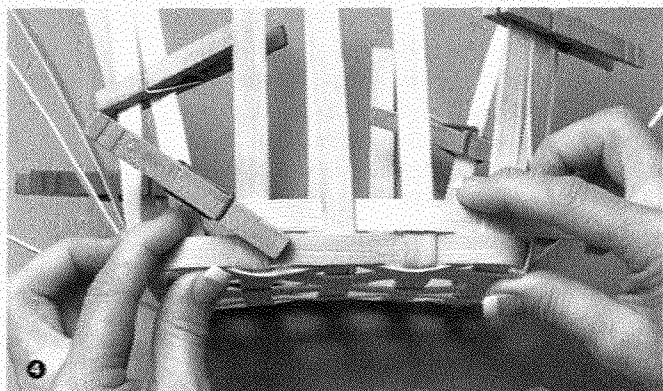

Step 4: Begin row 2—Choose a stake on another side of the basket that will allow you to weave opposite the first row. Use a clothespin to join a 1/2-inch flat weaver, right side out, to the front side of that stake and begin weaving as you did the first row. As you weave around the basket, you can remove any clothespins you placed.

Step 5—End the weaver by overlapping four stakes. Avoid overlapping around a corner, because the weave would become too bulky. Cut off the excess weaver and adjust the weave to pack down the row against the previous row.

Step 6—Keep a close watch on the tension while weaving rows 3 through 11 as in steps 4 and 5, following the chart below to determine what size reed to use for each row. As your weavers and stakes begin to dry out, lightly mist them with water. Remember to use a packing tool or small screwdriver to pack down each row. If any of the stakes begin to lean inward, loosen the tension of the weaving.

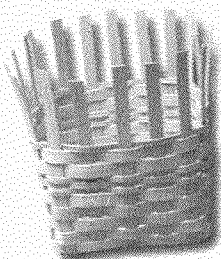

Row 3 1/2-inch flat weaver
Row 4 1/2-inch flat weaver
Row 5 1/2-inch flat weaver
Row 6 1/4-inch flat weaver
Row 7 1/4-inch flat weaver

Row 8 1/4-inch flat weaver
Row 9 1/2-inch flat weaver
Row 10 1/2-inch flat weaver
Row 11 1/4-inch flat weaver

Step 7—Place the two rim pieces, #3 round reed, and the long 1/4-inch flat *lasher* in water to soak.

Avoid starting a new row in the same place that the weaver ended. Doing so will concentrate overlap in the same area, causing the basket to bulge. Also avoid overlapping the beginning or end of a weaver around a corner; this can cause unappealing bulk in your basket.

Cut and Tuck

Step 1—The stakes must be damp before proceeding. If necessary, mist the spokes to dampen them.

Step 2—Cut off the stakes on the inside only of the last row, level with the top of the basket. Be careful not to cut off the wrong stakes!

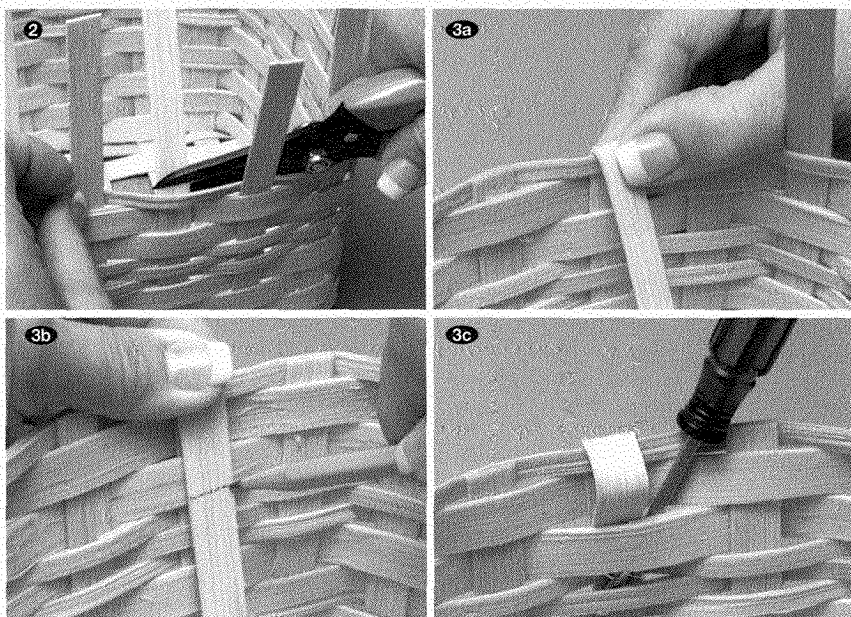

Step 3—Fold the outside stakes over the top of the last row of weaving and down inside the basket (3a). Use a pencil (3b) to mark each stake even with the bottom of the 1/2-inch weaver of row 9 (top row). Trim the stakes at the lines and tuck the ends under the weaving of row 9. Be careful not to cut the stakes too short. Use a small screwdriver to help you lift the weaving as you tuck each stake (3c).

Apply the Rim

Step 1—Use clothespins to secure the outside rim reed, right side out, to the center stake of any side of the basket. Begin laying the reed so that the bottom of the rim piece covers the last row of weaving. With clothespins, fasten the rim onto the basket as you go (1a), placing clothespins at every other stake, until you return to the beginning. Overlap the beginning of the reed by 2 to 3 inches (1b), and trim any excess.

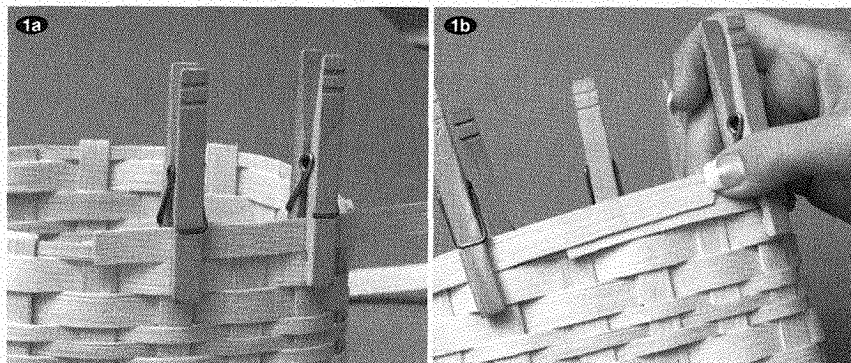

Step 2—Place the inside rim on the *opposite side* of the basket from the outside rim, with the wrong side of the reed touching the inside of the basket. Fasten this rim to the basket using clothespins, and overlap it 2 to 3 inches as you did the outside rim. Trim any excess.

Step 3—Place the #3 round reed in the groove between the rims, overlapping the ends about $\frac{1}{4}$ inch. The reed should be flush with the rims. Trim any excess.

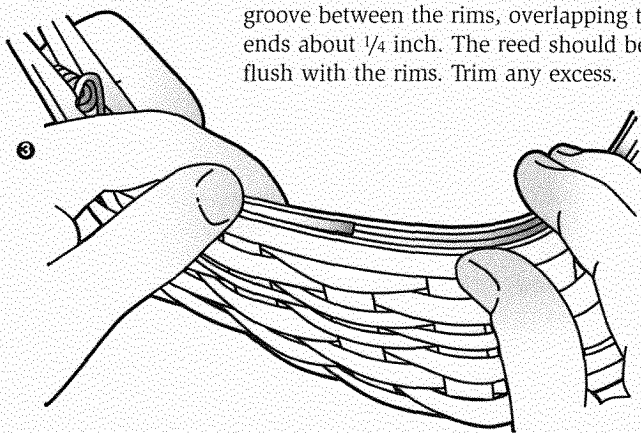

Lashing

Step 1—Hide the beginning lasher.

Slip about 6 inches of the lasher, wrong side out, up between the inside rim and the inside wall of the basket, under the rim filler, and down between the outside basket wall and the outside rim.

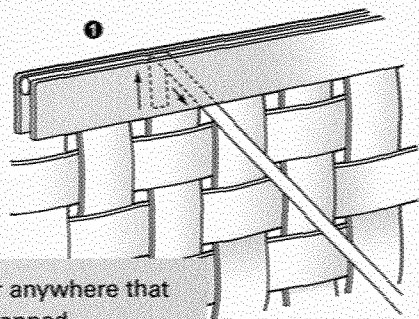

Be careful not to begin on a corner or anywhere that the rim or rim filler is spliced or overlapped.

Step 2—Bring the end of the lasher between two stakes, under the last row of weaving, to the inside of the basket, completing a loop around the last row of hidden weaving.

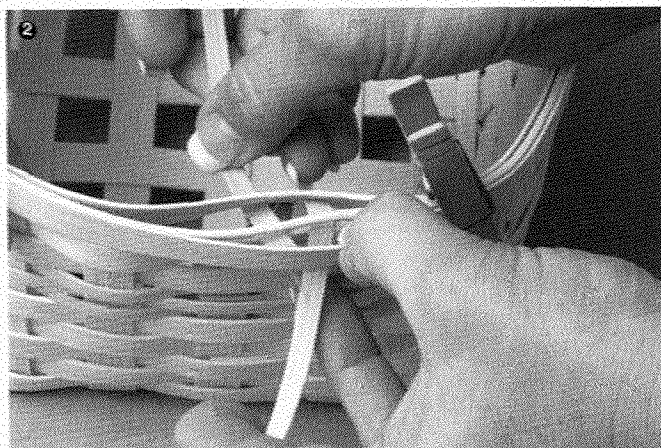

Step 3—Again draw the tail of the lasher up between the inside rim and the inside basket wall, over the top of the last row, under the rim filler, and down between the basket wall and the outside rim. The tail will be on the front side of the basket. **Do not cut the tail at this time.**

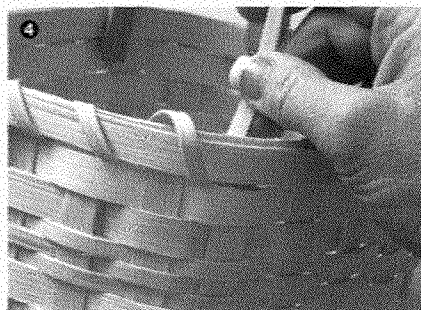

Step 4—Lashing the rim. With the lasher secured, feed the other end of the lasher to the right of the hidden loop and between two adjacent stakes, going from the front side of the basket to the inside. Pull the lasher tight to the rims. Repeat this looping and tightening process between each stake, all the way around the basket rims. Be careful to keep the lasher flat against the rims and to keep it from twisting.

Step 5—Ending the lasher. Hide the other end of the lasher by drawing the tail up between the inside rim and the inside basket wall, under the rim filler, over the top of the last row, and down between the basket wall and the outside rim. Repeat steps 2 and 3, just as you did to hide the lasher in an earlier step. Cut off the beginning tail and the excess lasher.

If you have hidden the lasher correctly, the right side of the lasher will lay over the top of the rims as you lash.

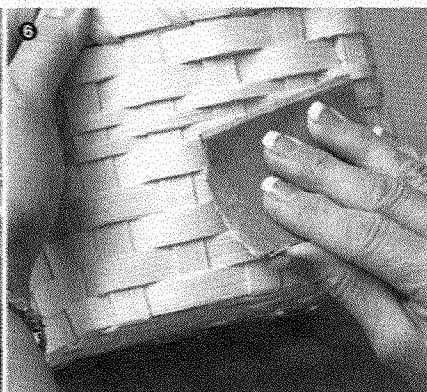
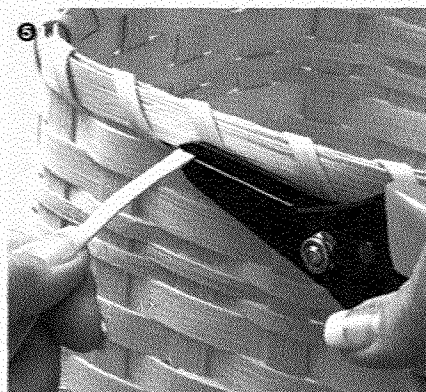

Step 6—When the basket dries, sand the reed and trim off any frayed fibers. Use a fine-tip permanent marking pen to sign and date your basket on the underside.

Round Basket

A beginning weaver with a little experience can tackle this project. It uses a continuous weave.

Basket Dimensions

Base: 5 inches

Height: 4½ inches

Circumference: approximately
16 inches

Materials Needed

- About 20 feet of ½-inch flat reed
- About 20 feet of #3 round reed
- About 42 feet of ¼-inch flat reed

Preparation

Cut the following pieces of reed before you start to weave.

- Spokes** Cut eight 18-inch spokes from ½-inch flat reed
- Twining** Cut one 180-inch length of twining from #3 round reed
- Weavers** Gather enough lengths of ¼-inch flat reed to make 37 feet.
- Rims** Cut two 20-inch rims from ½-inch flat reed
- Rim filler** Cut one 20-inch rim filler from #3 round reed
- Lasher** Cut one 60-inch lasher from ¼-inch flat reed

Weave the Base

Step 1—Soak the spokes and the 160 inches of #3 round reed in water for three to five minutes. Remove the spokes from the water, and blot each with a towel.

Step 2—With a pencil, lightly mark the center of all eight spokes on the wrong side of the reed. On four of the spokes, also mark 1½ inches away from each side of the center mark.

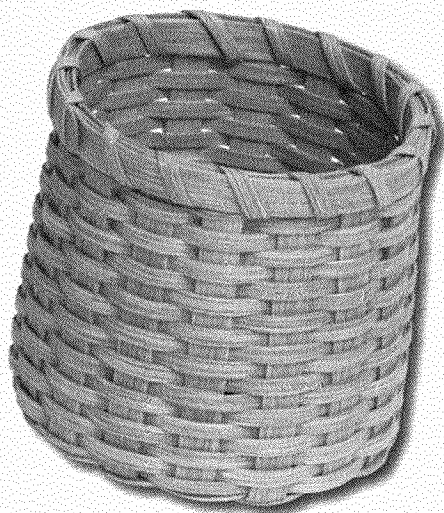

Step 3—Lay the four spokes with the 1½-inch marks across each other, matching the center marks, so they resemble the spokes in a wheel.

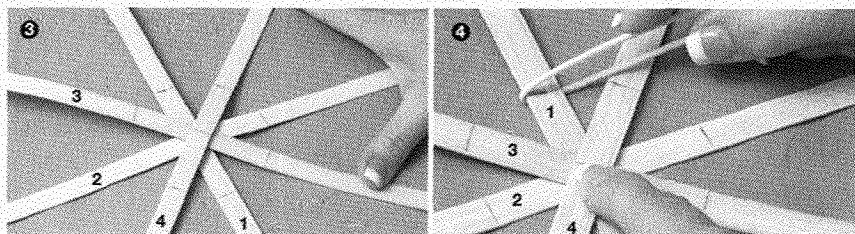

Step 4—Find the center of the #3 round reed and crimp the reed at this midpoint with needle-nose pliers. Fold the reed at the crimp. Loop the fold around the first half-inch spoke that you laid down on your working surface. Place the loop directly on top of the pencil mark so that half the weaver is on top of the spoke and the other half is under the spoke. Both ends should be on the inside of the basket. To twine correctly you must keep all weaving material on top of the spokes.

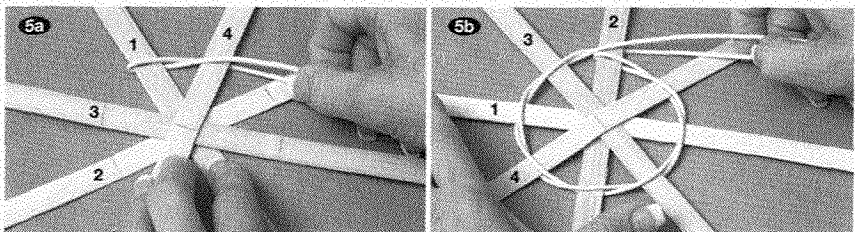

Step 5—(Note: The first row of the twining should begin at the 1½-inch mark of each spoke. The marks create a guide to help keep the circle's shape.) To begin, take the weaver that is on top of spoke 1 (weaver 1) and go down between spokes 1 and 2, under spoke 2, and up between spokes 2 and 3. Let go of weaver 1, and pick up weaver 2 (5a). Go down between spokes 2 and 3, under spoke 3, and up between spokes 3 and 4. Let go of weaver 2. Pick up weaver 1 and repeat this twisting process by alternating weavers until you complete a full circle around the base (5b). Keep tension in the weaver and pack the rows as you go so no space remains between the weaving. Check after each row to ensure that the circle has a good shape and that the spokes are evenly spaced.

Step 6—Twine for three rows. Mist the weavers and spokes with water.

Step 7—Lay the remaining four spokes in the spaces between the first four spokes.

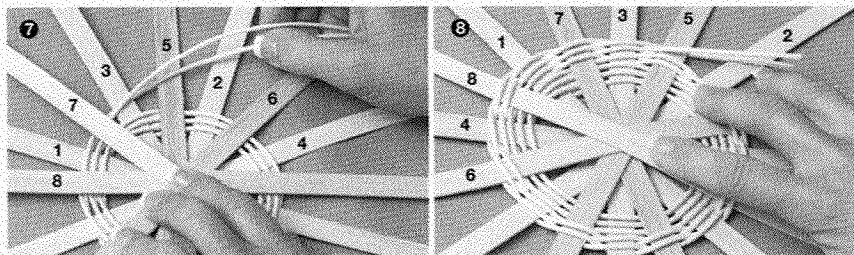

Step 8—Continue to twine for three more rows; include each new spoke as you approach it. End by tucking the tails behind previous rows of twining. The base should be 5 inches across.

Step 9—Place the 1/4-inch weavers in water.

Step 10—Mist the spokes with water, then upset them by bending them toward the center of the basket. Do not worry if they crack.

If you run out of weaver during the twining process, don't worry. You can add a new weaver as the old one runs out. Be sure to end the twining by trimming the excess and tucking the tails into the last row of twining.

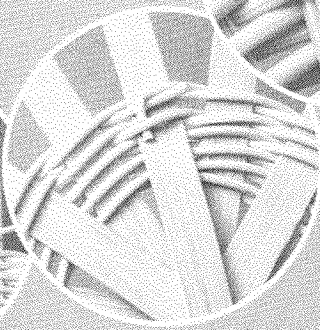
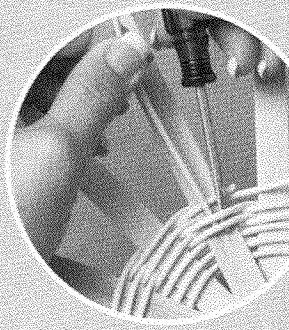
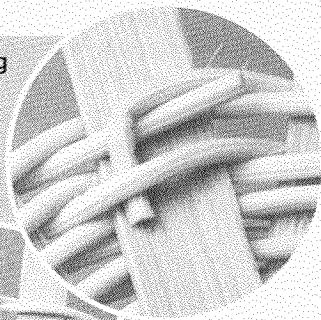

Weaving the Sides

Continuous weaving requires an odd number of spokes, so you must split one down the middle to create two spokes before you can begin weaving.

Step 1—Choose one spoke and use scissors to cut it into two spokes all the way down to the twining.

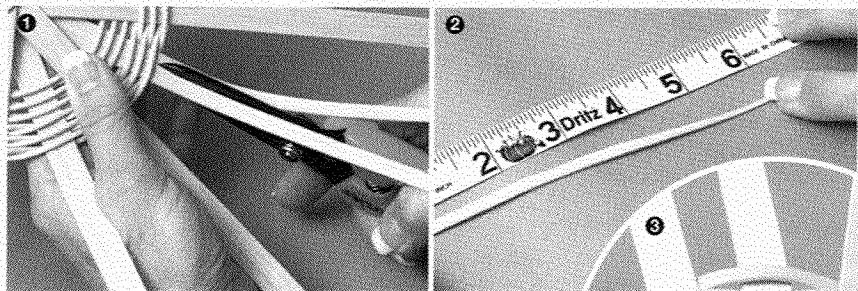

Step 2—Remove a long piece of $\frac{1}{4}$ -inch flat reed from the water. Taper the weaver, beginning from about 6 inches from the end. Using a tapered weaver will ensure that a continuous-weave project comes out level at the top.

Step 3—Insert the tip of the tapered weaver into the twining behind the spoke that is to the right of the split spoke, making sure the right side of the weaver will be on the outside of the basket when you gently pull the weaver to the front of the basket. Begin weaving over and under all the way around the basket. When you come to the split spoke, treat it as two individual spokes. If you have woven correctly you will be able to continue weaving around the basket without interrupting the weave.

Be careful not to put too much tension on the weaver, as that will cause the basket to get narrower as you approach the top. Measure the basket as you go to make sure that the cylinder shape remains the same size from bottom to top. If the circumference of the basket is larger than 16 inches, the rims will not fit. If it gets smaller, there will not be enough space between spokes to lash the rim.

Step 4—Weave 18 rows, adding a new length of weaver as you run out. Make sure the right side of the reed is on the outside of the basket and that you overlap four spokes when you add the new weaver. Pack down each row snugly against the previous row. About every three rows, check to make sure the spacing between each spoke is uniform. **Note:** Do not add a new weaver at a split spoke.

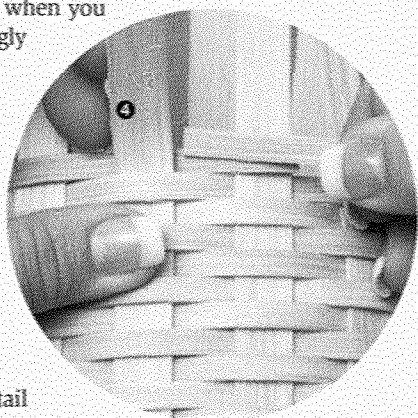

Adding a new weaver

Step 5—When you have completed the 18th row, you will be back to the split spoke. Cut the excess weaver, leaving enough length to weave behind three more spokes. Taper the end of the weaver approximately 6 inches, and continue to weave, finishing behind the third spoke to the right of the split spoke (see the arrow). Leave a small tail that can be folded down and tucked into the weavers below it. Trim the excess weaver.

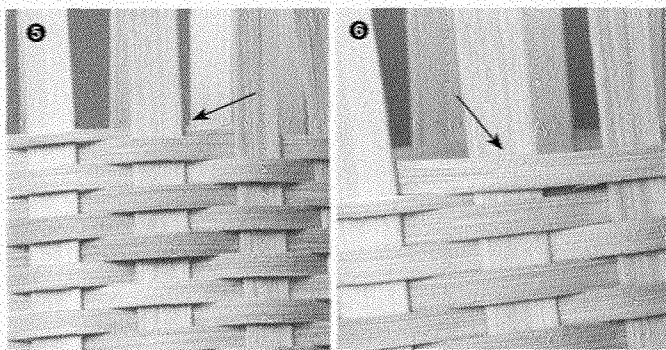

Step 6—Using a new piece of $\frac{1}{4}$ -inch weaver, weave one over-under row, continuing to treat the split spoke as two spokes. When you reach a point where the weaving follows the same pattern as the previous row, weave over two spokes to correct the problem (see the arrow). This will occur where the previous tapered row ended. Then return to the under-over weaving pattern. Complete the last row of weaving by overlapping two to four spokes.

Step 7—Soak the $\frac{1}{2}$ -inch rim pieces, rim filler, and $\frac{1}{4}$ -inch lasher in warm water for three to five minutes.

Remember to always pack each row snugly against the previous row, carefully monitor the spacing between each spoke, and keep the spokes and weaving materials damp.

Cut and Tuck

Step 1—If necessary, mist the spokes to dampen them.

Step 2—Cut off the spokes on the inside only of the last row, level with the top of the basket. Be careful not to cut off the wrong spokes!

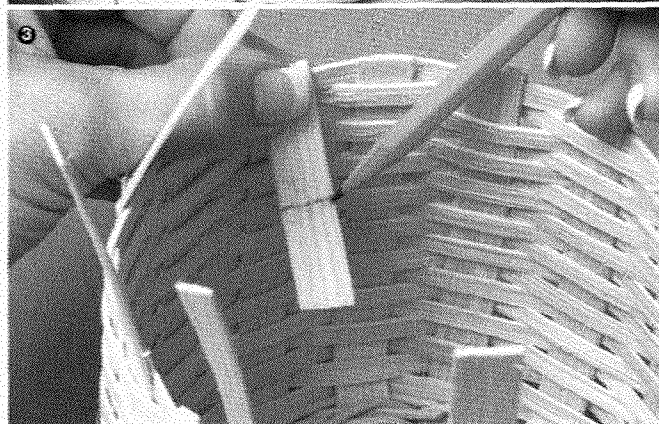
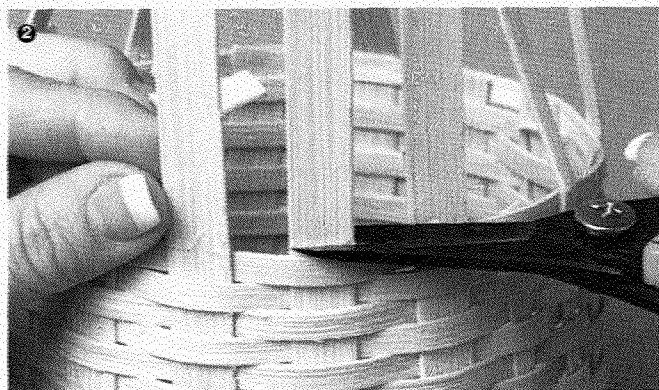

Step 3—Fold the outside spokes over the top of the last row of weaving and down inside the basket. Use a pencil to mark each spoke about two or three rows from the top of the basket. Trim the spokes at the lines and tuck the ends under two or three rows of weaving.

Apply the Rim

Step 1—Use clothespins to fasten the outside rim reed, right side out, to a spoke. Begin laying the reed so that the bottom of the rim piece covers the last row of weaving. Use clothespins along the rim as you go, placing one at every other spoke. When you return to the beginning, overlap 2 to 3 inches of reed and trim any excess.

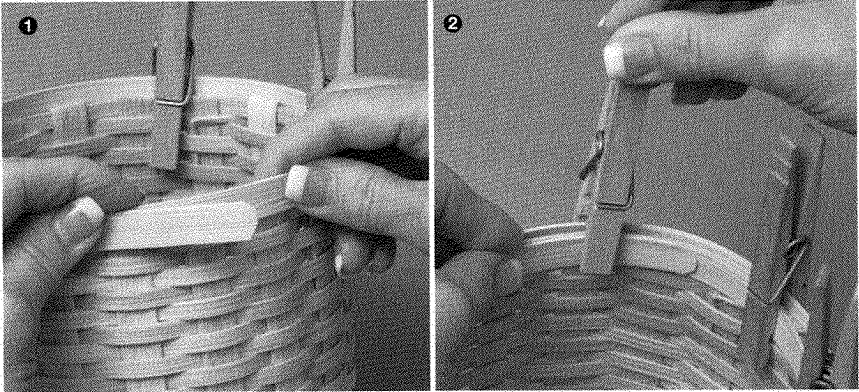

Step 2—Place the inside rim on the opposite side of the basket from the outside rim, with the wrong side of the reed touching the inside of the basket. Fasten this rim to the basket using clothespins. Trim any excess.

Step 3—Place the #3 round reed in the groove between the rims, overlapping the ends about 1/4 inch. Trim any excess.

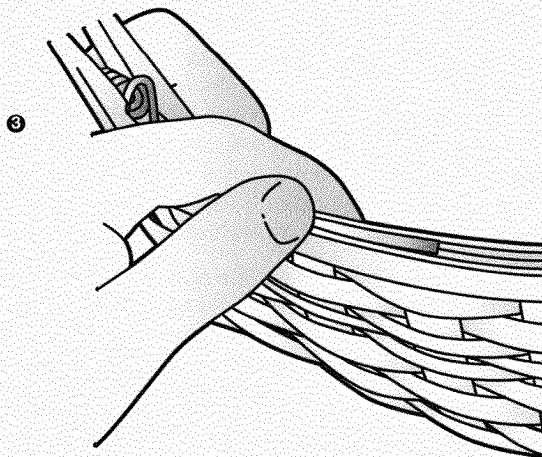

Be careful not to begin where the rim or rim filler is spliced or overlapped.

Lashing

Step 1—Hide the beginning lasher. Slip about 6 inches of the lasher, wrong side out, up between the inside rim and the inside wall of the basket, under the rim filler and down between the outside basket wall and the outside rim.

Step 2—Bring the end of the lasher between two spokes, under the last row of weaving, to the inside of the basket, completing a loop around the last row of weaving.

Step 3—Again draw the tail of the lasher up between the inside rim and the inside basket wall, over the top of the last row, under the rim filler, and down between the basket wall and the outside rim. The tail will be on the front side of the basket. **Do not cut the tail at this time.**

If you have hidden the lasher correctly, the right side of the lasher will lay over the top of the rims as you lash.

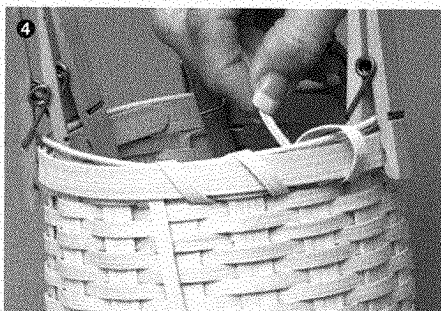

Step 4—Lashing the rim. With the lasher secured, feed the other end of the lasher to the right of the hidden loop and between two adjacent spokes, going from the front side of the basket to the inside. Pull the lasher tight to the rims. Repeat this looping and tightening process between each spoke, all the way around the basket rims. Be careful to keep the lasher flat against the rims and to keep it from twisting.

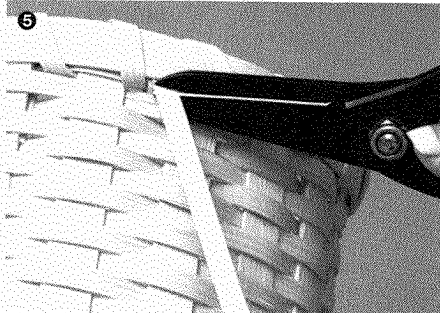

Step 5—Ending the lasher. Hide the other end of the lasher by drawing the tail up between the inside rim and the inside basket wall, under the rim filler, over the top of the last row, and down between the basket wall and the outside rim, repeat steps 2 and 3 as you did to hide the lasher in the beginning. Cut off the beginning tail and the excess lasher.

Step 6—When the basket dries, sand the reed and trim off any stray fibers. Use a fine-tip permanent marking pen to sign and date your basket on the underside.

Campstool Seat

This project, designed for the beginner who has considerable practice in basket weaving, is both easy to make and durable. It uses a twill weave.

Seat Dimensions

9 by 12 inches

Materials Needed

- 9-by-12-inch frame
- Several very long pieces of $\frac{1}{2}$ -inch flat reed, about 77 feet

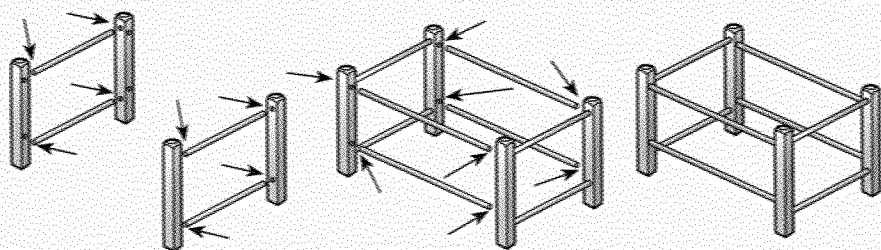

Step 1—Assemble the frame.

Step 2—Soak several long pieces of reed in water.

Step 3—With the long end of the frame facing you and the smooth side of the reed facing up, use a cable tie or masking tape to secure a long piece of reed to the inside, front left corner of the frame.

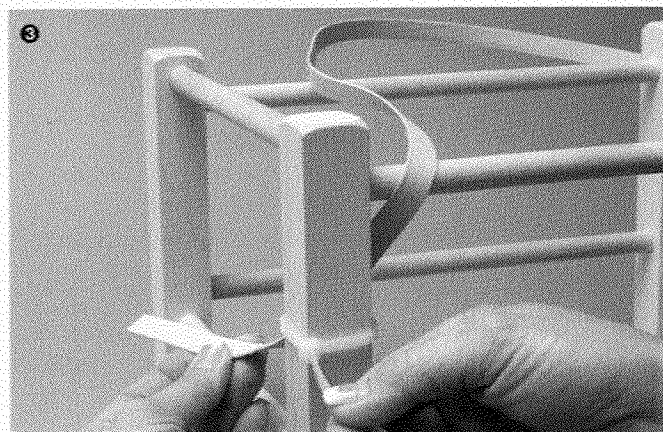

Step 4— Wrap the reed around the rails from front to back until the rungs are covered, approximately 21 wraps. Keep the edges of the reed touching as you add wraps. Keep the wrapping fairly loose; the wraps will tighten up as you weave the seat.

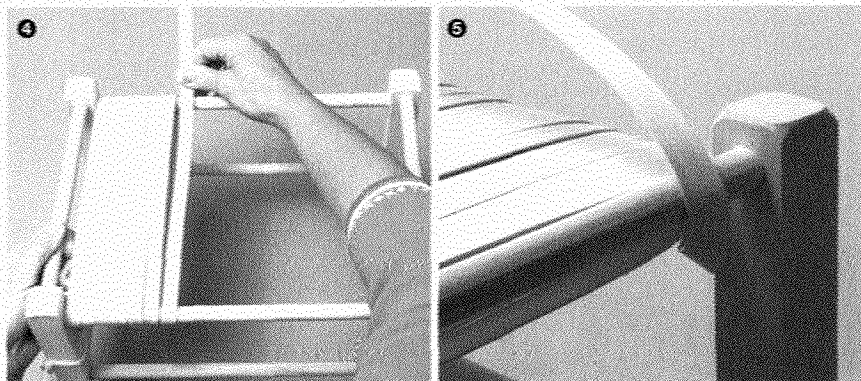

Step 5— When you reach the last wrap, bring the weaver over the back rail, around the inside of the leg, and over the side rail toward the top of the frame. This will allow you to continue using the same length of reed as you change direction on the frame. When you complete this step, the weaver will be going from right to left. Rotate the frame 180 degrees so that the weaver goes from left to right.

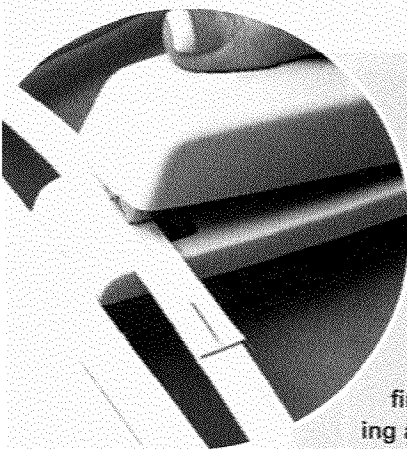

During the wrapping process, you might need to add another long weaver. Do this by overlapping the ends of the old and new weavers about 3 inches and stapling them together two or three times, with the staple points facing the inside of the seat. Note: Overlap and staple the two pieces of reed near the center of the seat on the underneath side. This will make it easier to hide the staples when you do the finish work on the seat. Be careful when adding a new weaver to keep the smooth side of the reed toward the outside of the seat.

Weaving the Pattern

You will weave the top of the seat then turn it over and weave the underneath side of the seat. As you weave this twill pattern, pack the weaving closely together with the edges of the rows touching. The twill pattern is woven in four rows, then the pattern is repeated three more times. This takes concentration because the weave is always changing. The critical part is starting each row correctly, because after the weave is started, a simple over two-under two pattern follows. You can refer to the master pattern chart to help you remember how to begin each row.

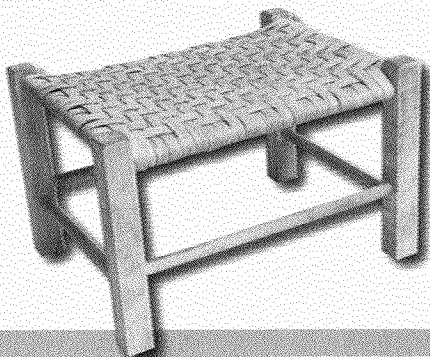

Always add a new weaver to the twill weave in the center of the bottom side of the seat by overlapping three or four stakes. There is no need to staple the ends:

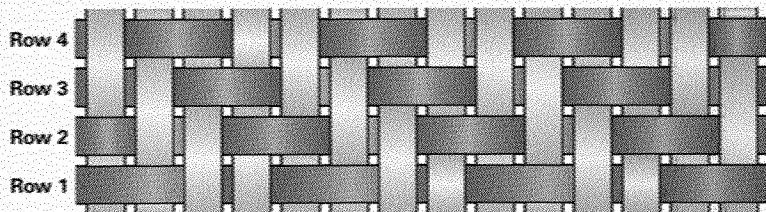

Master Pattern Chart

Row **Begin the Weave**

Row 1 *Over two, then repeat under two-over two pattern*

Row 2 *Over one, then repeat under two-over two pattern*

Row 3 *Under two, then repeat over two-under two pattern*

Row 4 *Under one, then repeat over two-under two pattern*

Step 1—Begin row 1 by weaving *over two*, then repeating an under two, over two pattern until you complete this row on the front side. (The row might not end with a complete over two, under two pattern.) Turn the frame over, wrap the weaver around the side of the frame, and weave row 1 again on the backside. Turn the frame back over and begin row 2.

Step 2—Begin row 2 by weaving *over one*, then repeat an under two, over two pattern until you complete this row on the front side. Turn the frame over, wrap the weaver around the side of the frame, and weave row 2 again on the backside. Turn the frame back over and begin row 3.

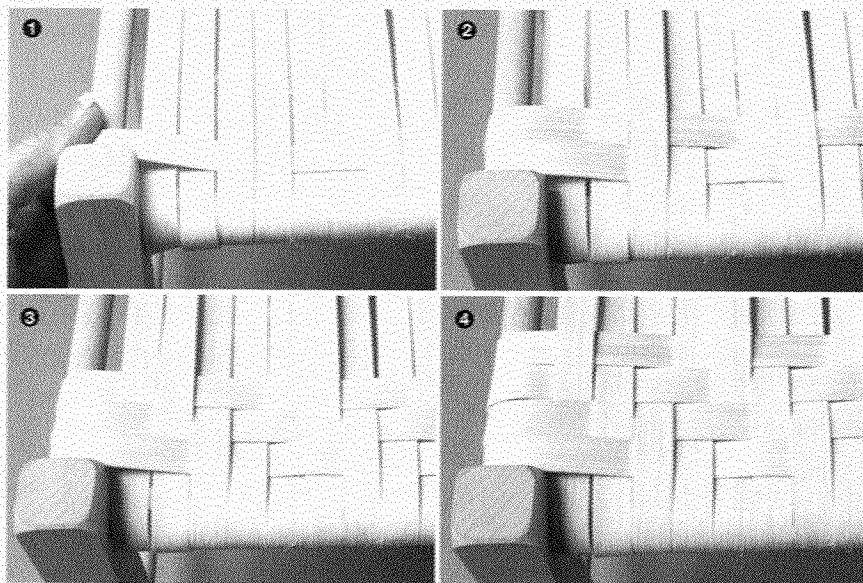

Step 3—Begin row 3 by weaving *under two*, then repeat an over two, under two pattern until you complete this row on the front side. Turn the frame over, wrap the weaver around the side of the frame, and weave row 3 again on the backside. Turn the frame back over and begin row 4.

Step 4—Begin row 4 by weaving *under one*, then repeat an over two, under two pattern until you complete this row on the front side. Turn the frame over, wrap the weaver around the side of the frame, and weave row 4 again on the backside. Turn the frame back over, and you will be ready to begin row 1 again.

Step 5—Repeat rows 1, 2, 3, and 4 as in steps 1 through 4 above. Then repeat rows 1, 2, 3, and 4 again.

Step 6—Repeat rows 1, 2, and 3. These last three rows of twill weave will be difficult to weave because the weaving in the seat begins to tighten up. You may have to use your needle nose pliers to pinch the end of the reed and gently pull it through the reeds.

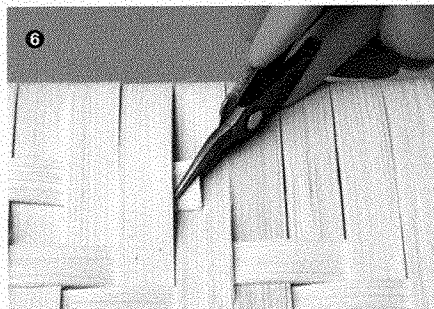

Step 7—At the end of the last row on the bottom side of the seat, cut the remaining weaver the length of the stool and weave it in as far as it will go. Hide the end under three or four reeds.

Step 8—Remove the cable tie or masking tape carefully and mist the reed with water. Cut the remaining weaver the length of the stool and weave it in as far as it will go, hiding the end under three or four reeds.

Step 9 (optional)—To cover any visible staples underneath the seat, slide a piece of reed directly over the top of the reed that you stapled, then tuck the ends under two or more woven reeds. The staples also could be carefully removed; the weaving will be secure enough to hold.

Step 10—Allow the reed to dry completely, then sand any unwanted fibers off the reed and trim. Use a fine-tip permanent marking pen to sign and date your seat on the bottom.

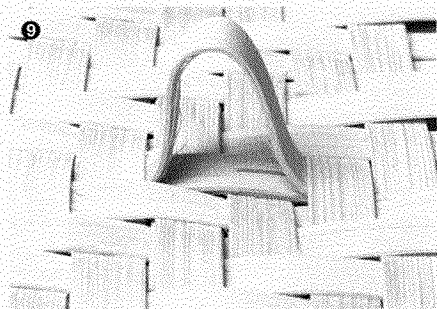

Remember to mist your weaving material with water to keep it from drying out. Be careful not to wet the wooden frame.

The projects in this pamphlet are available in kits through the BSA National Distribution Center. See the resources section in the back of the book.



American Indian Basketry

American Indians have used woven objects in countless ways. Their beds, thatched roofs, floor mats, sandals, insulated boots, baby carriers, boat bailers, berry baskets, rain hats, and backpacks were all fashioned from plants, grasses, and tree bark. Baskets could even be used for cooking over hot stones. Strong and lightweight, baskets could be shaped to fit the user's needs. Basketry entered the home, furniture, clothing, armor, religion, and eventually the trade economy of American Indian peoples.

While baskets provided many common uses among American Indian peoples, many tribes found basketry to be a ready solution to problems that were unique to their territory. The following examples illustrate how the American Indian influence on basket making varied across North America.

Plateau Indians. The Nez Perce tribe is remembered for exquisite basketry that features bright geometric designs. Nez Perce women wore basketwork hats woven from plant fibers. The Wasco and Wishram tribes of Oregon developed an unusual "X-ray" style for basketry designs. The skeletons of the artists' subjects could be seen in designs portraying animals and humans, as though the artists had looked through the flesh.

Pueblo. In A.D. 400, the Pueblo peoples of the Southwest used prairie grasses to weave sandals that looked similar to today's flip-flops.

Navajo. The Navajo learned many of their basketry skills from the Pueblos. They made ceremonial trays and other objects, as well as practical items like water jugs and burden baskets for gathering fruit. The Navajo prefer to



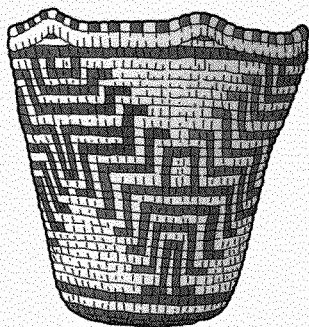

Plateau tribes were renowned for their basketmaking.

The Cherokee added color to their work with natural dyes, including black extracted from butternut, orange from bloodroot, brown from walnut, and a pale yellow from yellowroot. The designs they wove into their baskets depicted important tribal and clan symbols.

use sumac and yucca in their basketry, mainly because Navajo legend holds that a weaver who uses willow will go blind. The most famous of the Navajo basket designs is the wedding basket, depicting the Earth and its mountains, with a break in the design to allow the spirits to emerge.

Cherokee. Throughout the 1700s and early 1800s, the Eastern Cherokee used white oak and cane to create baskets. In more recent times, they used honey-suckle vines and maple river cane, which grows up to 30 feet tall along river bottoms, has been used throughout the tribe's recorded history to fashion arrow shafts, blowguns, mats, and baskets.

Hopi. The Hopi word for basket weaving means "peaceful." The works created by these quiet artisans carried the pride and craftsmanship of their makers, and the finished pieces often were elaborate works of art that were cherished in life and buried with the dead. The Hopi people used paints and dyes from minerals and crushed berries, as well as beautiful stones and shells, to decorate their works. They cut the sinew of small animals into strings for handles and straps, and used the animal skins as soft, strong lining for baskets, baby carriers, and bags.

Pomo. Like other tribes from the California region, the Pomo fashioned reeds, grasses, roots, and barks into all manner of articles: trays, containers, cooking pots, hats, mats, fish traps, baby carriers, ceremonial objects, and even boats. They decorated their finely crafted baskets with shells and feathers.

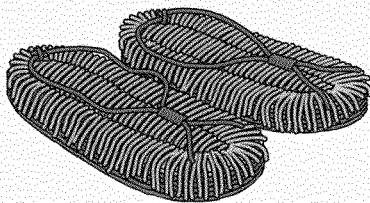

On long trips, Californians might wear yucca-fiber sandals, with soles almost 1 inch thick.

O'odham and Tohono O'odham. These tribes from southern Arizona made detailed baskets and even wove cotton fibers into fabric.

Other Tribes. Members of nomadic tribes such as the Ute and Apache created water-tight, lightweight baskets for traveling. Shoshone and Athabaskan people made canteens, pitchers, and small water storage tanks from coiled or twined weaves sealed with pine tar or asphaltum.

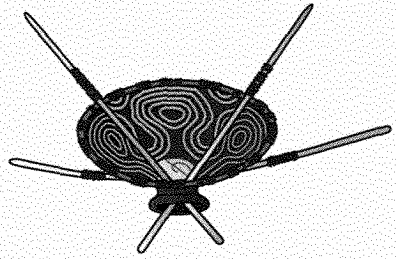

An O'odham carrying-basket

Respect for Mother Earth

American Indians share a deep and abiding respect for the land and have practiced conservation techniques for thousands of years. For example, the Eastern Cherokee people of North Carolina, Tennessee, and northern Georgia never took the first plant they saw. Cherokee weavers searched until they discovered an area where plants grew plentifully. Then they would carefully cut just a portion of each plant they harvested so that the grasses, vines, and trees would regenerate from year to year. They took only what they needed, then returned any leftover natural materials to the Appalachian Mountains, scattering them with thanks and gratitude to the Great Spirit for the Earth's abundance. This respect and stewardship for all living things is still a fundamental principle underlying the lives of all native peoples.



This 12-inch willow basket was made by Apache Indians in the early 1800s.

Emergency Baskets

Makeshift emergency baskets are some of the most fascinating woven crafts of all native peoples. These were made quickly and could be used to catch rainwater, bail out a leaky boat, transport goods to market, or carry all sorts of things—from live animals to yams.

For example, in central Africa, potters could cut long palm leaves to weave crude baskets that were shaped and sized to fit their loads on the way to market. The people of the Nicobar Islands near India wrapped palm leaves to create buckets, using vines to support the leaf bottom and hold the shape of the walls. In lower Thailand, leaves were folded and stitched with a bit of reed or rattan to be used as a boat bailer. Throughout the tropics, temporary baskets were made of fresh leaves from the cocoa palm to carry fish, game, or fruit.

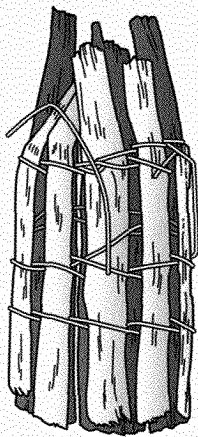

Burden basket

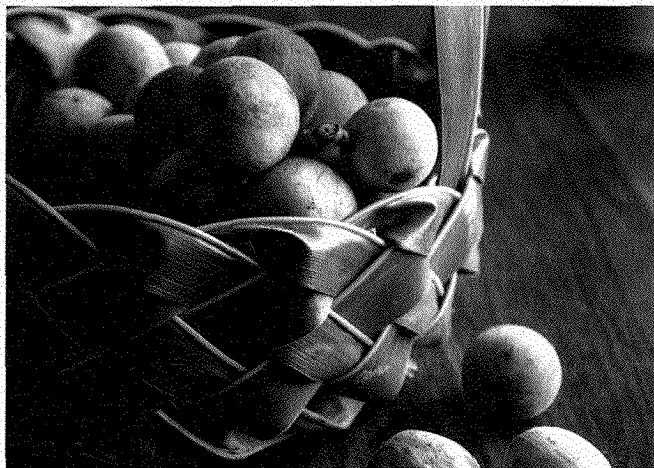

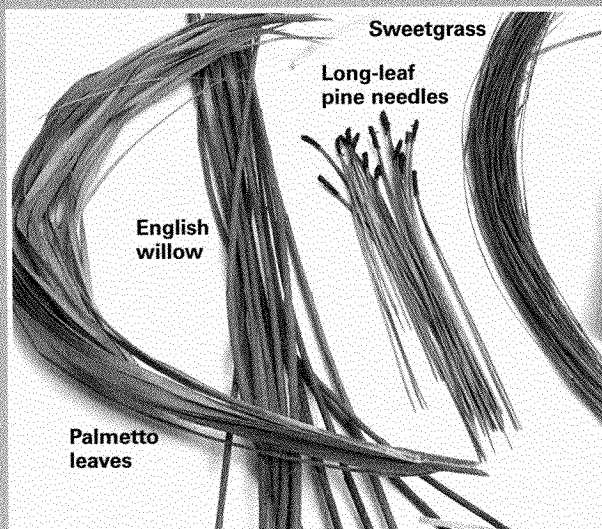

If you need to make an emergency basket, try to choose weaving material from saplings—less than a year old—with as few knots and buds as possible. Plants become more brittle with age, so a young plant is best suited for making an emergency basket because it will bend easily.

Make note of the types of plants found in your region that could be used to craft an emergency basket. Long-leaf pine needles are prevalent along the southeastern coast, while sweetgrass, or sweet flag, can be found in Georgia and South Carolina. Weavers in the Northeast use materials like birch bark and dogwood saplings, while Midwesterners could use grasses such as rye and wheat, cattail leaves, willow, sedges, and cornhusks. Various types of willow grow from Alaska throughout most of the northern United States. Grapevine and honeysuckle are abundant in temperate climates like Texas.

Basketry Terms

The following terms will be a useful reference as you complete your basketry projects.*

base. The bottom of a basket; woven mat.

cane. The material harvested from the inner bark of a tropical vine called *rattan*.

coiling. A weaving technique using a rigid core that is wrapped and stitched with a softer, more flexible material. Rows of the wrapped core are stacked and sewn together rather than woven.

continuous weave. Weaving done continuously over an odd number of stakes. It is not done one row at a time, but rather continuously from beginning to end, adding weavers periodically.

cut and tuck. When the basket is woven, the outside stakes are bent over the last row of weaving and tucked into the weaving on the inside of the basket; also called down staking. The inside stakes are cut off even with the top edge of the last row of weaving.

lasher. A piece of reed that secures the rim pieces; also referred to as *lashing*.

lashing. The act of wrapping all the rim pieces to the basket.

losing a lash. Hiding the end of the reed within the rim or weaving.

packing. Pushing down each row snugly beside the previous woven row.

pairing. A method of weaving (usually with round reed) using two weavers alternately in a twisting pattern in front of one spoke and behind one spoke; also called *twining*.

plaited. Woven.

plaiting. A weaving technique in which flat strips pass over and under each other at right angles.

plain weave. A simple over-one, under-one weave. Plain weave is sometimes referred to as over-under weave and is generally known as *basketweave*.

*These terms are used with permission of Sterling Publishing Co. Inc., New York, N.Y., from "The Basket Book" by Lyn Siler, ©1988 by Lyn Siler and Carolyn Kemp, a Sterling/Lark book.

rattan. A climbing palm (vine) from which reed is made.

reed. The inner core of the tropical vine *rattan* that has been cut into flat, round, flat-oval, half-round, or oval shapes and is used for baskets and furniture.

rib. The round or oval pieces that extend from one side of the basket to the other and form the basic skeleton.

rim. The pieces, inside and outside, that fit over the top row of weaving to form an edge and give stability to the sides of a basket.

rim filler. A piece of round reed or sea grass placed between the two rim pieces of the basket.

spoke. The same as a stake but laid in a circle as spokes in a wheel.

stake. Pieces of the woven mat (base) that are upset to become the upright elements of a basket.

twill. A method of weaving in which the weaver passes over and under two or more stakes at a time.

twining. A method of weaving (usually with round reed) using two weavers alternately in a twisting pattern in front of one spoke and behind one spoke; also called *pairing*.

upset. To bend the stakes up and over upon themselves (toward the base), creating a crease at the base of the stake. This action creates the side supports of the basket.

weaver. The fiber, often reed, that moves over and under the stakes, spokes, or ribs.

wicker. A basketry technique that employs round, vertical stakes or spokes, and round weavers, woven perpendicular to the spokes.



Basketry Resources

Books

- Barratt, Olivia Elton. *Basketmaking*. Henry Holt, 1993.
- Bibby, Brian. *Essential Art: Native Basketry from the California Indian Heritage Center*. Heyday, 2012.
- Crawford, BJ. *The Weekend Crafter: Basketry*. Lark Crafts, 2011.
- Crook, Georgia. *Basketmaking*. Crowood, 2000.
- Doney, Meryl. *Baskets*. Franklin Watts, 1997.
- Fariello, M. Anna. *Cherokee Basketry: From the Hands of Our Elders*. The History Press, 2009.
- Franz, Linda. *Basic Basket Making: All the Skills and Tools You Need to Get Started*. Stackpole Books, 2008.
- Harding, Stella. *Practical Basketry*. A&C Black, 2012.
- Hoppe, Flo. *Contemporary Wicker Baskets*. Lark Books, 1997.
- LaFerla, Jane. *Making the New Baskets: Alternative Materials, Simple Techniques*. Sterling, 2000.
- Peabody, Sarah, and William A. Turnbaugh. *Indian Baskets*. Schiffer Publishing, 1986.
- Siler, Lyn. *The Ultimate Basket Book: A Cornucopia of Popular Designs to Make*. Lark Books, 2006.
- Turnbaugh, Sarah P., and William A. Turnbaugh. *Indian Baskets*, 3rd ed. Schiffer Publishing, 2004.
- Yamane, Linda. *Weaving a California Tradition: A Native American Basketmaker*. Lerner Publications, 1997.

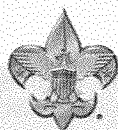

For your convenience, the BSA National Distribution Center has prepackaged kits available for the square basket, round basket, and campstool seat featured in this pamphlet.

National Distribution Center
 Boy Scouts of America
 P.O. Box 7143
 Charlotte, NC 28241-7143
 Toll-free telephone:
 800-323-0736
 Website:
<http://www.scoutshop.org>

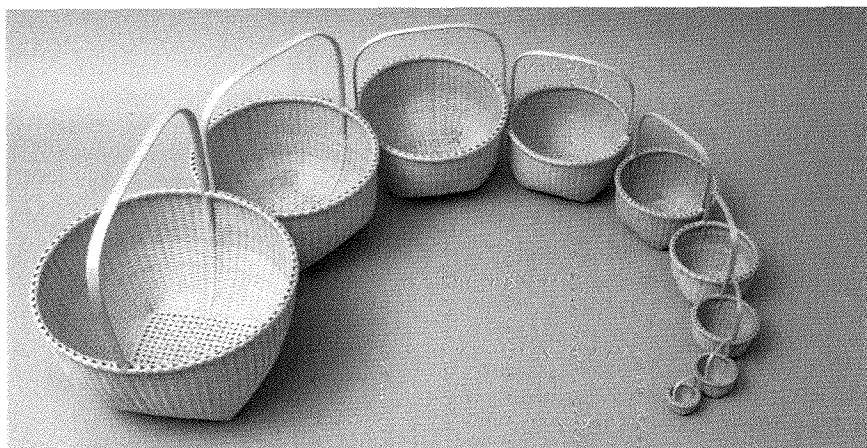

Organizations and Websites

Association of Michigan Basketmakers

Website:
<http://www.michiganbasketmakers.com>

BasketMakers

Website: <http://basketmakers.com>

National Basketry Organization

Telephone: 617-863-0366
Website:
<http://www.nationalbasketry.org>

North Carolina Basketmakers' Association

Website:
<http://www.ncbasketmakers.com>

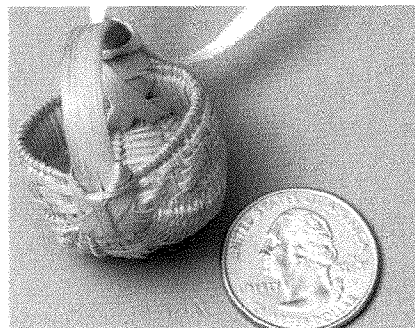

Basketry Suppliers

Baskets of Joy

Telephone: 207-725-5899
Toll-free telephone: 800-377-6097
Website: <http://www.basketsofjoy.com>

BasketWeavingSupplies.com

Toll-free telephone: 866-928-5430
Website:
<http://www.basketweavingsupplies.com>

The Country Seat Inc.

Telephone: 610-756-6124
Website: <http://www.countryseat.com>

Inter-Mares Trading Co. Inc.

Telephone: 631-957-3467
Toll-free telephone: 800-229-CANE
Website: <http://www.canefish.com>

Suzanne Moore's N.C. Basket Works

Toll-free telephone: 800-338-4972
Website: <http://www.ncbasketworks.com>

Paul's Supplies

Telephone: 303-948-2767
Website: <http://www.paulssupplies.com>

V.I. Reed & Cane

Toll-free telephone: 800-852-0025
Website: <http://www.basketweaving.com>

Acknowledgments

Jenalee Frazier has been a basket weaver for 20 years, authoring many patterns for the beginner to the advanced weaver. The BSA appreciates her sharing her vast knowledge of this art form and her beginner basketry patterns for this pamphlet. She has served as a Basketry merit badge counselor and taught young people how to weave as an artist-in-residence in public schools. She has traveled around the country to meet, teach, and learn techniques from weavers of many ethnic backgrounds. Mrs. Frazier was invited to create and weave an angel ornament for the White House Christmas tree.

Mrs. Frazier revised, with permission, an original campstool pattern written by **Carol Matteson** from *The Stool Collection, A Child's Size Stool*.

Linda Hebert has been a basket weaver and basketry teacher for more than 25 years. With her husband, she is co-owner of V.I. Reed & Cane, a web-based business at <http://www.basketweaving.com>. Ms. Hebert writes a monthly newsletter on basket-weaving tips and instruction. The BSA appreciates Ms. Hebert's permission to use weaving tips from her website.

Lyn Siler is the author of several popular books on basketry. The BSA thanks Ms. Siler for her basic weaving terminology and weaves excerpted from her book for this pamphlet. These terms were used with permission of Sterling Publishing Co. Inc.

The Boy Scouts of America is grateful to the men and women serving on the National Merit Badge Subcommittee for the improvements made in updating this pamphlet.

Photo and Illustration Credits

HAAP Media Ltd., courtesy—cover
(*cone-shaped basket, small yellow and white basket*)

Shutterstock.com—page 42 (*coconut leaf basket, ©Vittee*)

U.S. Geological Survey, courtesy—page 41 (*willow basket*)

U.S. Library of Congress Prints and Photographs Division, courtesy—page 38

Wikipedia.org, courtesy—cover (*pine needle basket*)

All other photos and illustrations are the property of or are protected by the Boy Scouts of America.

Vince Heptig—pages 4, 8 (*both*), 9 (*reed*), 14, 17 (*measuring*), 22 (*clothespins*), 23 (*lashing*), 24 (*all*), 26–30 (*all*), 31 (*clothespins*), 32, and 46–47 (*both*)

John McDearmon—pages 9, 22–23, 31, 33, 35, and 39–42

MERIT BADGE LIBRARY

Though intended as an aid to youth in Scouts BSA, and qualified Venturers and Sea Scouts in meeting merit badge requirements, these pamphlets are of general interest and are made available by many schools and public libraries. The latest revision date of each pamphlet might not correspond with the copyright date shown below, because this list is corrected only once a year, in January. Any number of merit badge pamphlets may be revised throughout the year; others are simply reprinted until a revision becomes necessary.

If a Scout has already started working on a merit badge when a new edition for that pamphlet is introduced, *they may continue to use the same merit badge pamphlet to earn the badge and fulfill the requirements therein.* In other words, the Scout need not start over again with the new pamphlet and possibly revised requirements.

Merit Badge Pamphlet	Year	Merit Badge Pamphlet	Year	Merit Badge Pamphlet	Year
American Business	2013	Family Life	2016	Plant Science	2018
American Cultures	2013	Farm Mechanics	2017	Plumbing	2012
American Heritage	2013	Fingerprinting	2014	Pottery	2008
American Labor	2018	Fire Safety	2016	Programming	2013
Animal Science	2014	First Aid	2015	Public Health	2017
Animation	2015	Fish and Wildlife Management	2014	Public Speaking	2013
Archaeology	2017	Fishing	2013	Pulp and Paper	2013
Archery	2015	Fly-Fishing	2014	Radio	2017
Architecture and Landscape Architecture	2014	Forestry	2015	Railroading	2015
Art	2013	Game Design	2013	Reading	2013
Astronomy	2016	Gardening	2013	Reptile and Amphibian Study	2018
Athletics	2016	Genealogy	2013	Rifle Shooting	2012
Automotive Maintenance	2017	Geocaching	2016	Robotics	2016
Aviation	2014	Geology	2016	Rowing	2014
Backpacking	2016	Golf	2012	Safety	2016
Basketry	2017	Graphic Arts	2013	Salesmanship	2013
Bird Study	2017	Hiking	2016	Scholarship	2014
Bugling (see Music)		Home Repairs	2012	Scouting Heritage	2017
Camping	2018	Horsemanship	2013	Scuba Diving	2009
Canoeing	2014	Indian Lore	2008	Sculpture	2014
Chemistry	2018	Insect Study	2018	Search and Rescue	2018
Chess	2016	Inventing	2016	Shotgun Shooting	2013
Citizenship in the Community	2015	Journalism	2017	Signs, Signals, and Codes	2015
Citizenship in the Nation	2014	Kayaking	2016	Skating	2015
Citizenship in the World	2015	Landscape Architecture (see Architecture)		Small-Boat Sailing	2016
Climbing	2011	Law	2011	Snow Sports	2017
Coin Collecting	2017	Leatherwork	2017	Soil and Water Conservation	2016
Collections	2013	Lifesaving	2017	Space Exploration	2016
Communication	2013	Mammal Study	2014	Sports	2012
Composite Materials	2012	Medicine	2012	Stamp Collecting	2013
Cooking	2014	Metalwork	2012	Surveying	2004
Crime Prevention	2012	Mining in Society	2014	Sustainability	2013
Cycling	2017	Model Design and Building	2010	Swimming	2014
Dentistry	2016	Motorboating	2015	Textile	2014
Digital Technology	2014	Moviemaking	2013	Theater	2014
Disabilities Awareness	2016	Music and Bugling	2013	Traffic Safety	2016
Dog Care	2016	Nature	2014	Truck Transportation	2013
Drafting	2013	Nuclear Science	2017	Veterinary Medicine	2015
Electricity	2013	Oceanography	2012	Water Sports	2015
Electronics	2014	Orienteering	2016	Weather	2013
Emergency Preparedness	2015	Painting	2016	Welding	2016
Energy	2014	Personal Fitness	2016	Whitewater	2005
Engineering	2016	Personal Management	2015	Wilderness Survival	2012
Entrepreneurship	2013	Pets	2013	Wood Carving	2016
Environmental Science	2015	Photography	2016	Woodwork	2011
Exploration	2016	Pioneering	2017		

BOY SCOUTS OF AMERICA • SUPPLY GROUP

NATIONAL DISTRIBUTION CENTER

2109 Westinghouse Boulevard
P.O. Box 7143
Charlotte, NC 28241-7143

To place an order,
call customer service
toll-free 800-323-0736
or go to
www.scoutshop.org

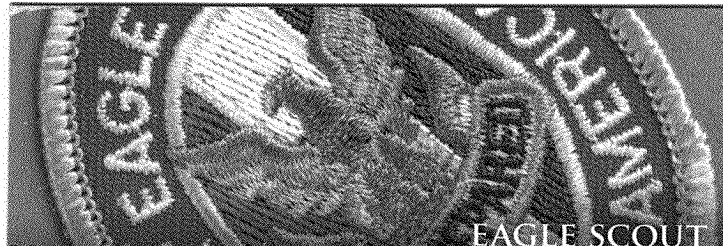

EAGLE SCOUT



THE SUMMIT



FLORIDA SEA BASE

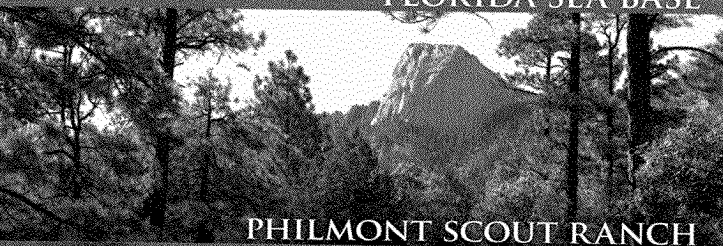

PHILMONT SCOUT RANCH



NORTHERN TIER

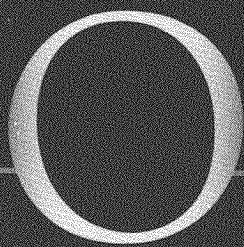

ON THE ROAD TO
HIGH ADVENTURE

THE SUPPLY GROUP IS
READY TO BE A PARTNER
ON YOUR TRAIL TO
EAGLE THROUGH HIGH
ADVENTURE. THE
ADVENTURE IS YOURS,
AND WE ARE READY
WITH THE GEAR YOU
WILL NEED. YOU CAN
DEPEND ON THE LATEST
IN LIGHTWEIGHT,
DURABLE, QUALITY
GEAR THAT WILL
MEET AND SURPASS
YOUR TOUGHEST
REQUIREMENTS.



WWW.SCOUTSHOP.ORG

SKU 650865



35864 2019 Printin



Certified Sourcing
www.sfi-program.org
sf-00358