

# MERIT BADGE SERIES

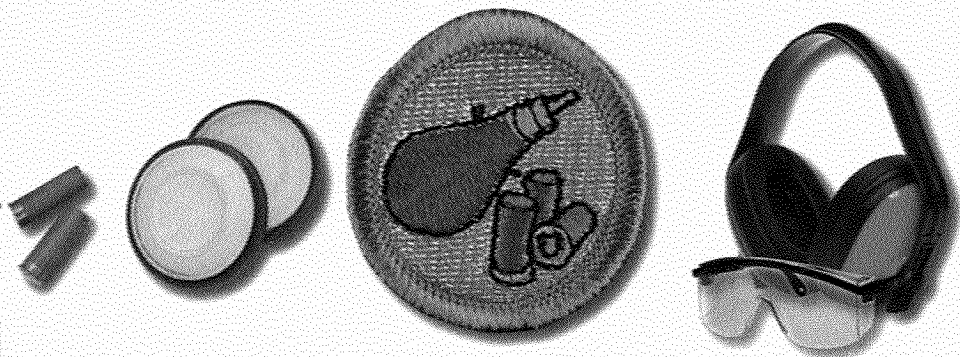

# SHOTGUN SHOOTING

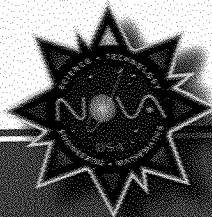

BOY SCOUTS OF AMERICA

STEM-Based



## HOW TO USE THIS PAMPHLET

The secret to successfully earning a merit badge is for you to use both the pamphlet and the suggestions of your counselor.

Your counselor can be as important to you as a coach is to an athlete. Use all of the resources your counselor can make available to you. This may be the best chance you will have to learn about this particular subject. Make it count.

If you or your counselor feels that any information in this pamphlet is incorrect, please let us know. Please state your source of information.

Merit badge pamphlets are reprinted annually and requirements updated regularly. Your suggestions for improvement are welcome.

Send comments along with a brief statement about yourself to National Advancement Committee, S209 • Boy Scouts of America • 1325 West Walnut Hill Lane • P.O. Box 152079 • Irving, TX 75015-2079 • [merit.badge@Scouting.org](mailto:merit.badge@Scouting.org).

## WHO PAYS FOR THIS PAMPHLET?

This merit badge pamphlet is one in a series of more than 100 covering all kinds of hobby and career subjects. It is made available for you to buy as a service of the national and local councils, Boy Scouts of America. The costs of the development, writing, and editing of the merit badge pamphlets are paid for by the Boy Scouts of America in order to bring you the best book at a reasonable price.

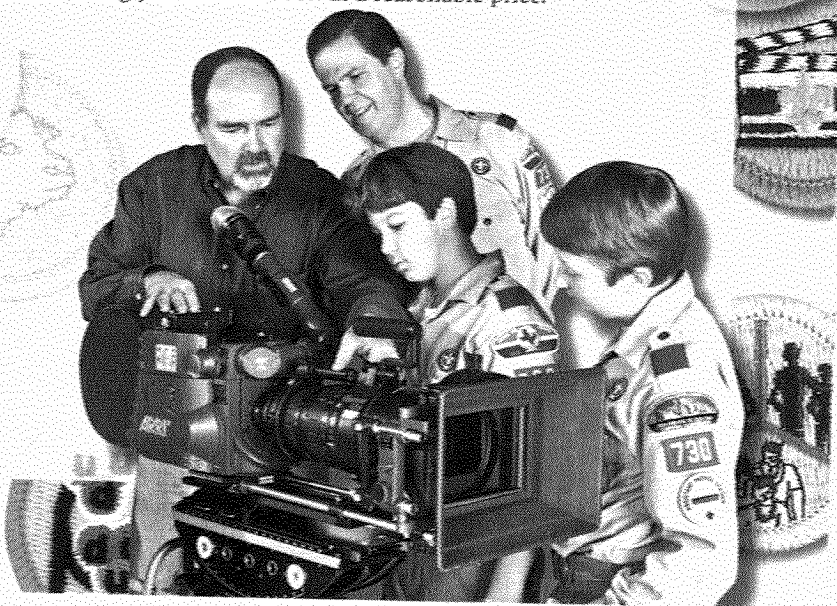

BOY SCOUTS OF AMERICA  
MERIT BADGE SERIES

# SHOTGUN SHOOTING



*"Enhancing our youths' competitive edge through merit badges"*



BOY SCOUTS OF AMERICA®

# Note to the Counselor

The merit badge counselor must take responsibility to assure that all instruction involving any handling of firearms or live ammunition must be supervised by a currently certified BSA National Camping School (NCS) shooting sports director or National Rifle Association (NRA) Shotgun Instructor or NRA Coach.

Instruction involving muzzleloading shotguns must be supervised by an NCS shooting sports director or NRA/National Muzzleloader Rifle Association (NMLRA)-certified muzzleloading shotgun instructor. Shooting must be supervised by an NRA-certified Range Safety Officer (RSO).

If instruction and shooting are to occur at the same time, both the RSO and NRA instructor must be present. The NRA Range Safety Officer and NRA instructor may not be the same person. Note that commercial shooting ranges may provide RSOs. See the *Guide to Safe Scouting* and the *BSA National Shooting Sports Manual*, No. 30931, for further details on shooting sports.

Boy Scouts are permitted to fire .22-caliber bolt-action, single-shot rifles; air rifles; shotguns; and muzzleloading long guns. BSA policy does not permit the use of handguns by Boy Scouts or Varsity Scouts. It is recommended that the merit badge counselor use the current *Shotgun Shooting* merit badge pamphlet, No. 35948, and the "NRA FIRST Steps Shotgun Orientation Instructor's Lesson Plans/BSA Shotgun Shooting Merit Badge Teaching Guide" found in the *National Shooting Sports Manual*, No. 30931.

## Shotguns

The following standards are established for Boy Scouts, Varsity Scouts, and Venturers regarding shotgun usage.

1. Modern sporting shotguns of any gauge may be used. However, experience shows that beginning shooters will be more successful with a 20- or 12-gauge shotgun, putting more shot to the target. Youth- and adult-size gas-operated semiautomatic shotguns are recommended.

2. Current manufactured shotshells of the appropriate gauge containing No. 7 ½ to No. 9 shot may be used. A shot size larger than No. 7 ½ is not to be used. Reloads may not be used in BSA shooting sports programs.
3. Shooting safety glasses and hearing protection must be worn on shotgun ranges.
4. Care must be taken to comply with federal, state, and local laws.

### **Muzzleloaders**

The following standards for muzzleloading shotguns are to be used by members of the BSA.

1. Only recently manufactured (or assembled from a kit) percussion cap muzzleloading shotguns no smaller than 20 gauge or greater than 10 gauge are to be used. Flintlock shotguns are not approved for use in BSA shooting sports programs. Shotguns made from kits must be checked by a qualified gunsmith.
2. Only a commercially manufactured, sporting grade black powder or black powder substitute offered for sale by a reputable firm should be used in muzzleloading shotguns. For new shooters, the amount of propellant in grains should be at the minimum of the gun manufacturer's recommended load range.
3. Shooting safety glasses and hearing protection must be worn.
4. Care must be taken to comply with federal, state, and local laws.

# Requirements

1. Do the following:
  - a. Explain why BB and pellet air guns must always be treated with the same respect as firearms.
  - b. Describe how you would react if a friend visiting your home asked to see your or your family's firearm(s).
  - c. Explain the need for and use and types of eye and hearing protection.
  - d. Explain the main points of the laws for owning and using guns in your community and state.
  - e. Explain how hunting is related to the wise use of renewable wildlife resources.
  - f. Successfully complete a state hunter education course, or obtain a copy of the hunting laws for your state, then do the following.
    - (1) Explain the main points of hunting laws in your state and give any special laws on the use of guns and ammunition, and
    - (2) List the kinds of wildlife that can be legally hunted in your state.
  - g. Explain to your counselor the proper hygienic guidelines used in shooting.
  - h. Identify and explain three shotgun sports. Identify places in your community where you could shoot these sports and explain how you can join or be a part of shooting sports activities.
  - i. Give your counselor a list of sources that you could contact for information on firearms and their use.

2. Do ONE of the following options:

### **OPTION A—SHOTGUN SHOOTING**

#### **(Modern Shotshell Type)**

- a. Identify the principal parts of a shotgun, action types, and how they function.
- b. Identify and demonstrate the rules for safely handling a shotgun.
- c. Identify the parts of a shotgun shell and their functions.
- d. Identify the various gauges of shotguns. Explain which one you would pick for use and why.
- e. Identify and explain the fundamentals of safely shooting a shotgun. Explain what a misfire, hangfire, and squib fire are, and explain the procedures to follow in response to each.
- f. Identify and explain each rule for safely shooting a shotgun.
- g. Demonstrate the knowledge, skills, and attitude necessary to safely shoot moving targets, using the fundamentals of shotgun shooting.
- h. Identify the materials needed to clean a shotgun.
  - i. Demonstrate how to clean a shotgun properly and safely.
  - j. Discuss what points you would consider in selecting a shotgun.
- k. Shooting score required—Hit at least 12 out of 25 targets (48 percent) in two 25-target groups. The two groups need not be shot in consecutive order. A minimum of 50 shots must be fired.

Shooting skill rules:

- Targets may be thrown by a hand trap, manual mechanical trap, or on any trap or skeet field. Note: If using a hand trap or manual mechanical trap, the trap operator should be at least 5 feet to the right and 3 feet to the rear of the shooter. If throwing left-handed with a hand trap, the trap operator should be at least 5 feet to the left and 3 feet to the rear of the shooter.

- All targets should be thrown at a reasonable speed and in the same direction.
- Targets should be generally thrown so as to climb in the air after leaving the trap.
- Scores may be fired at any time, either in formal competition or in practice.
- Any gauge shotgun not exceeding 12 gauge may be used.
- Only commercially manufactured ammunition may be used. Reloads may not be used in BSA shooting sports programs.
- Shooters must shoot in rounds of 25. Rounds need not be shot continuously or on the same day (the term “round” refers to a single series of 25 shots).
- If using a trap field, shoot station 3 with traps set to throw straightaway targets.
- If using a skeet field, shoot station 7 low house.

### **OPTION B—MUZZLELOADING SHOTGUN SHOOTING**

- a. Discuss a brief history of the development of the muzzleloading shotgun.
- b. Identify principal parts of percussion and flintlock shotguns and discuss how they function.
- c. Demonstrate and explain the rules of safely handling a muzzleloading shotgun.
- d. Identify the various grades of black powder and their proper and safe use.
- e. Discuss proper safety procedures pertaining to black powder use and storage.
- f. Discuss proper components of a load.
- g. Identify proper procedures and accessories used for safely loading a muzzleloading shotgun.



- h. Demonstrate the knowledge, skills, and attitude necessary to safely shoot a muzzleloading shotgun on a range, including range procedures. Explain what a misfire, hangfire, and squibfire are, and explain the procedures to follow in response to each.
- i. Shoot a moving target with a muzzleloading shotgun using the five fundamentals of firing the shot.
- j. Identify the materials needed to clean a muzzleloading shotgun properly and safely.
- k. Demonstrate how to clean to clear a muzzleloading shotgun's failure to fire and explain or demonstrate proper correction procedures.
- l. Identify the causes of a muzzleloading shotgun's failure to fire and explain or demonstrate proper preventive procedures.
- m. Discuss what points you would consider in selecting a muzzleloading shotgun.
- n. Shooting score required—Hit at least 5 out of 15 targets in each of two 15-target groups. The two groups need not be shot in consecutive order. A minimum of 30 shots must be fired. Shooting skill rules:
- Targets may be thrown by a hand trap, manual mechanical trap, or on any trap or skeet field. Note: If using a hand trap or manual mechanical trap, the trap operator should be at least 5 feet to the right and 3 feet to the rear of the shooter. If throwing left-handed with a hand trap, the trap operator should be at least 5 feet to the left and 3 feet to the rear of the shooter.
  - All targets should be thrown at a reasonable speed and in the same direction.
  - Targets should be generally thrown so as to climb in the air after leaving the trap.
  - Scores may be fired at any time, either in formal competition or in practice.

- Any gauge shotgun not exceeding 10 gauge may be used.
- Standard clay targets customarily used for trap and skeet are to be used.
- On a standard trap field, the shooter should be positioned 8 yards behind the trap house. The trap should be set to throw only straightaway targets.
- On a skeet field, use station 7 low house.



## Contents

Shotgun Parts . . . . .	10
Shotgun Ammunition . . . . .	18
Shotgun Safety . . . . .	23
Fundamentals of Shotgun Shooting . . . . .	34
Choosing a Shotgun . . . . .	46
Clay Target Sports . . . . .	51
Muzzleloading Shotguns . . . . .	61
Conservation and Hunting . . . . .	81
Glossary . . . . .	86
Shotgun Shooting Resources . . . . .	94

## Shotgun Parts

A shotgun is a precision instrument, designed to shoot a shot charge in a specific pattern to cover a designated area at a certain distance. Unlike a rifle, the bore of the shotgun is not rifled, so the shot emerging from the muzzle is not spinning.

A shotgun is built to last a lifetime. By itself, the shotgun poses no greater threat to person or property than any other machine. If you understand your gun—how it works, how to use it safely, and how to care for it—shooting will be pleasurable and rewarding.

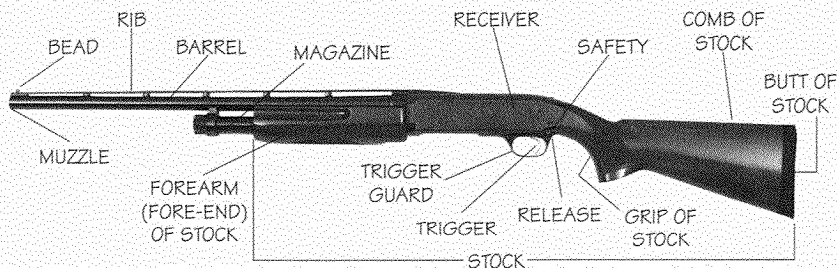

### Shotgun parts

#### The Stock

The *stock* is the gun's handle. It has a special significance in proper shooting. It is designed to let you point and shoot accurately. Each part of the stock has a special name.

The *butt* is the rear end of the stock. It's the part that rests against your shoulder when you point the shotgun.

The *comb* is the part of the stock that is brought to your cheek as you assume the shooting position.

The *grip* is the part of the stock held with the trigger hand. It sometimes is referred to as the *small* of the stock because it is where the stock narrows.

The part of the stock that lies under the barrel is called the *forearm*, or *fore-end*. On most shotguns, the forearm is separate from the rest of the stock.

## The Barrel

The *barrel* is the metal tube through which the shot passes on its way to the target. The inside portion of the barrel is called the *bore*, and its diameter will vary depending on the size of the gun. Most shotgun bores are designated by a term known as *gauge*. The smaller the gauge number, the larger the bore diameter.

Starting with the largest bore, most modern shotguns are available in 10, 12, 16, 20, and 28 gauge. The lone exception to this measuring system is the .410 bore shotgun, the smallest of the modern shotguns. It has a bore measured by the same standards as rifles and pistols.

Modern shotguns are loaded at the rear, or *breech*, end of the barrel by inserting a round of ammunition known as the *shotshell* into the part of the barrel called the *chamber*. The front of the barrel—where the shot exits the gun—is called the *muzzle*.

---

The .410 shotgun has a bore that is 410/1,000 of an inch in diameter. While it is commonly referred to as the .410 gauge, the gun actually is a 67 gauge.

---

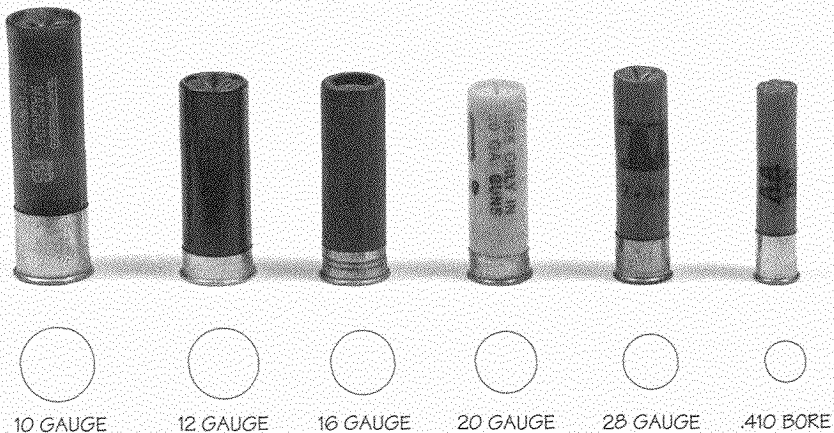

Popular shotshell gauges, with circles representing the shell's actual diameter.

### The Choke

Most shotguns have, near the muzzle, an important constriction called the *choke*. Shot begins to spread out as soon as it exits the muzzle, so the more constricted the shot is at the time it's expelled, the farther it will travel as a compact group. The choke's function is to constrict the shot. The greater the choke, the greater the constriction and generally the greater the effective range of the gun and shot pattern.

Most commonly, a full-choke shotgun barrel has the most constriction and the greatest range. However, at close range a full-choke pattern may be too small to consistently hit moving targets or so dense that game is ruined by blanket shot.

While the most common chokes are discussed here, there are many variations in between. For information about the choke on your shotgun, consult the manufacturer's user manual.

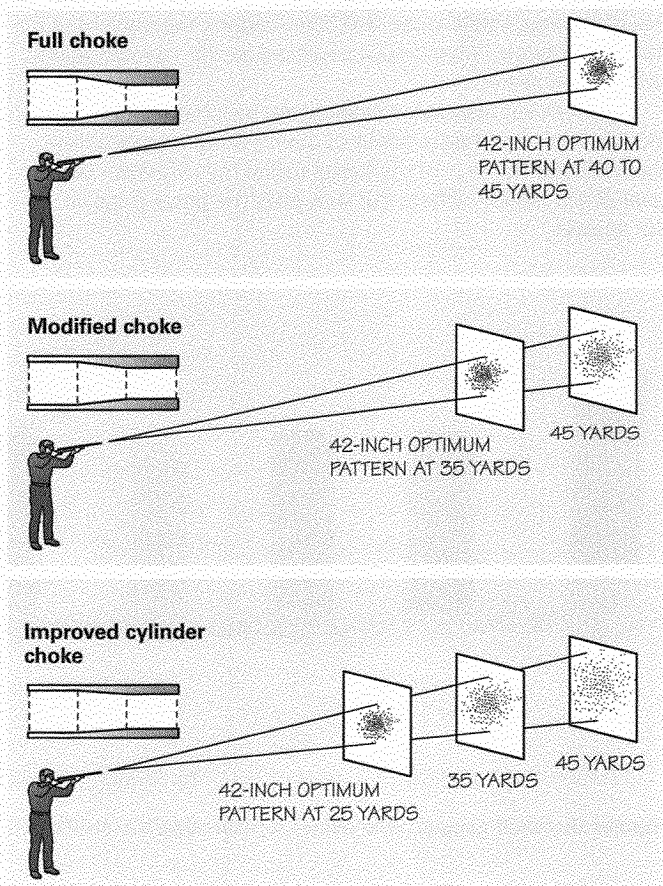

Modified choke creates somewhat less constriction than full choke. Improved cylinder choke creates even less constriction, providing a shot pattern that widens out more quickly than the preceding two. A shotgun barrel that has no choke at all is referred to as a *cylinder bore*. Generally, choke designations are indicated on the outside of the barrel.

Many companies today manufacture shotguns with interchangeable screw-in chokes. Or, a device known as an adjustable choke can be placed on the end of the barrel to allow the user to adjust choke selections. Both of these options are good if one gun is to serve multiple purposes.

The *sighting* mechanism on shotguns is rather simple. One or sometimes two *beads* are positioned on the top of the barrel to help the shooter point at the target. Some shotguns also have a *rib* that runs the length of the barrel and gives the shooter an added tracking aid. The ribbed surface also helps keep the barrel cooler during heavy fire.

## The Action

The moving parts that permit you to load, fire, and unload your shotgun are known as the *action*. Most of these parts are housed in a metal frame called a *receiver*. Many different methods have been designed for operating the action. Among the most common types are *break action*, *pump*, and *semiautomatic*. In each case, the ultimate function is the same.

By opening the action, you usually are causing the *firing pin* spring to compress and allowing a shotshell to be loaded into the chamber at the breech end of the barrel. Closing the action on most shotguns means the gun is cocked and ready for firing.

To open or close the action on many firearms after loading, you must activate the action release button or lever.

When the gun has been loaded and the action closed, place the *safety* in the “on” position. Move the safety to the “off” position right before firing. Once the gun is cocked and the safety off, you can point the shotgun at the target and pull the trigger, which drives the firing pin forward. When the firing pin strikes the *primer* in the base of the shell case, the shotshell will fire.

Once the shot is fired, you can reopen the action to either eject or remove the fired case. On most shotguns, opening the action will eject the fired case automatically. Then, a new shotshell can be loaded, the action closed, and the gun fired again.

### Action Types

**Pump.** The actions of the pump-type shotguns are opened and closed by pumping the forearm of the stock back and forth. Pump actions are sometimes called *slide actions*.



Pump action shotgun



**Hinge.** Similar to the movement of a door hinge, a shotgun's break action can be opened when the release lever on top of the action is pushed to one side, separating the standing *breechblock* from the barrel. Based on placement, these actions are referred to as either "over and unders" or "side by sides."

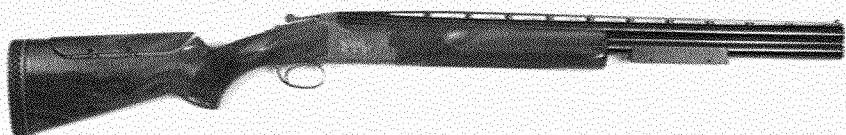

Over and under  
(hinge) shotgun  
and action

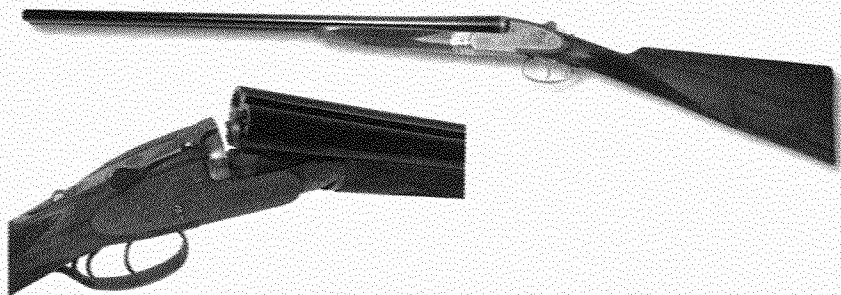

Side-by-side (hinge) shotgun and action

**Semiautomatic**, or *autoloading*. The semiautomatic action operates automatically when the shot is fired. In most semiautomatic shotguns, gas from the burning gunpowder provides the energy needed to operate the action and load the next shell. This type of action delivers less *recoil*, or kick, to the shooter.

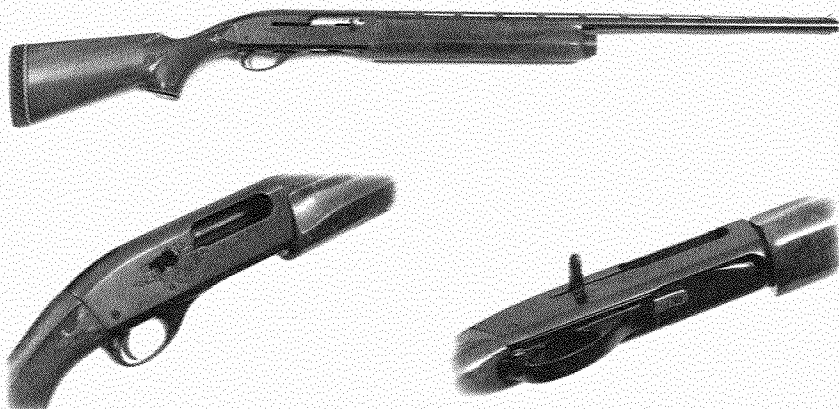

Semiautomatic shotgun and action

## The Magazine

Most shotgun actions can be loaded manually, one shell at a time. Many, however, have a *magazine* to help speed up loading. The magazine is a container attached to the gun into which several shells can be placed. Closing the action on loaded shotguns equipped with a magazine will allow a new shell to be placed in the chamber. The gun can be fired successively until the magazine is empty.

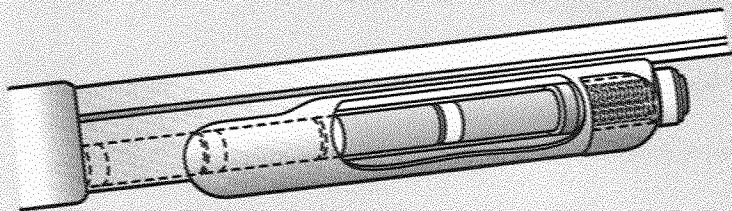

Of the two basic types of magazines, the most common is a tube type positioned under the barrel, as shown. The second is a box type located directly under the receiver.

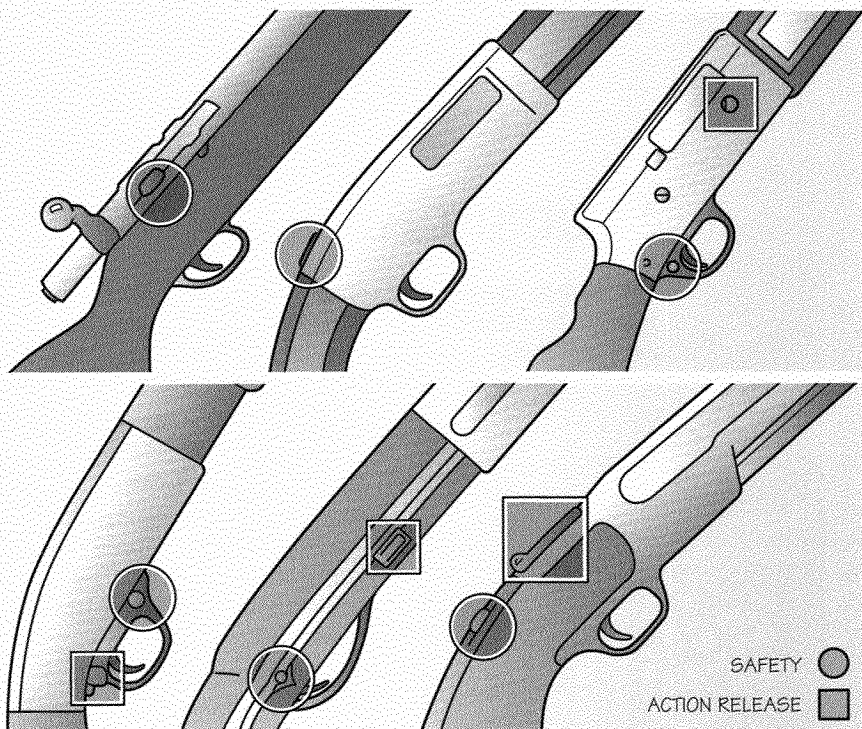

While they serve two distinct functions, the safety and action release of a shotgun are both small levers that can be located at varying places on the gun.

## The Safety

Regardless of the type of action employed, all modern shotguns come equipped with a mechanical *safety* to help guard against unwanted firing. A loaded shotgun should be carried only when the safety is on.

Under no circumstances should a gun's safety be substituted for a shooter's good safety habits. As mechanical devices, safeties are subject to malfunction and shooter error. Therefore, even when the safety is in the "on" position, the responsible shooter always treats his gun as if firing were possible.

---

On shotguns with two barrels and only one trigger, the safety button usually also functions as a selector to determine which barrel will fire first.

---



# Shotgun Ammunition

The modern shotgun shell contains the five components required for firing the shot: the *case*, *primer*, *powder charge*, *wad*, and *shot*.

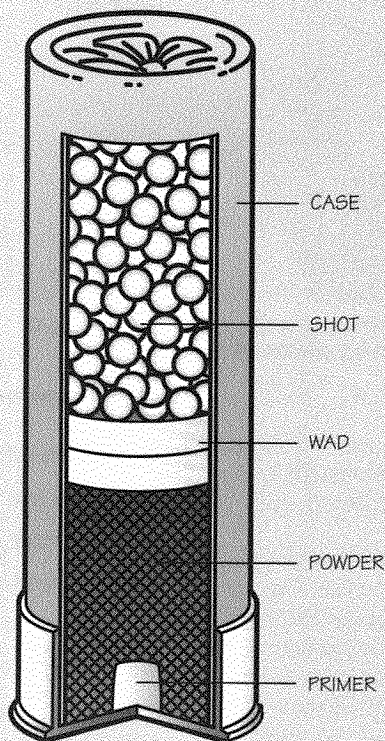

- The shell **case** is the outer container for all other ammunition parts. It typically is made of plastic or paper with a metal base.
- The **primer** is the detonating agent contained in the middle of the shell's base. When the firing pin strikes the primer, a chain of events begins to fire the gun.
- A **powder charge** above the primer allows easy combustion from the flame created when the primer detonates.
- A plastic or fiber **wad** separates the shot from the powder, forming a seal that allows the gases created by the burning powder to push the shot down the barrel.
- **Shot** are small round projectiles usually made of lead or steel and are located at the front end of the shell. Depending on the gauge and shot size, one shell may contain anywhere from nine to 700 of them.

To understand these components, you must understand the way modern firearms work.

<b>Shot Size</b>			
<b>Identification No.</b>	<b>Shot diameter (inches)</b>	<b>Number of lead shot in an ounce</b>	<b>Common uses</b>
No. 9	.08	585	Skeet, woodcock, quail
No. 8	.09	410	Trap, skeet, dove, quail, woodcock
No. 7½	.095	350	Trap, dove, grouse, quail, pheasant, crow
No. 6	.11	225	Grouse, pheasant, rabbit, squirrel, crow
No. 5	.12	170	Pheasant, grouse, rabbit, squirrel, turkey
No. 4	.13	135	Ducks, turkey
No. 2	.15	90	Turkey, ducks

## How Shotgun Ammunition Fires

A shot begins when the shotgun's trigger is pulled and ends when the shot are expelled from the barrel. The first step occurs when the trigger is pulled and the firing pin strikes the primer, causing its priming compound to detonate. The flame generated by the primer ignites the powder charge. The rapidly burning powder generates a high volume of gases under tremendous pressure. Because the breech end of a shotgun is blocked and the muzzle is open, the gases will seek the path of least resistance through the bore and out the muzzle. In the way of these gases are the wad and shot, but because they give the least resistance, the gases push them along and out the muzzle. All this is done in a split second—at a velocity of about 1,250 feet per second. This velocity diminishes as the shot travels until it falls to Earth at a range of about 300 yards. After 50 to 60 yards, however, the shot has lost velocity and energy, and the pattern has become so widely dispersed that it is not likely to be effective on moving targets.

The length of a shotshell is its length in a fired condition. Using a shotshell longer than that for which the gun is designed can destroy the gun and may cause serious injury to the shooter and bystanders.

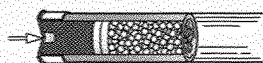

FIRING PIN STRIKES PRIMER.

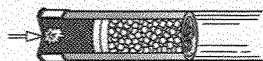

PRIMER DETONATES.

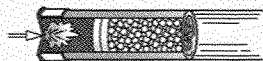

POWDER IS IGNITED.

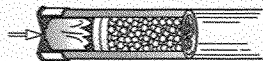

BURNING POWDER FORMS GASES.



EXPANDING HOT GASES PROPEL PROJECTILE.

### Using the Right Ammunition

The kind of ammunition you use will depend on the gauge of the gun and the kind of shooting you will do. Use only the shotshells that are right for your shotgun. Usually, modern shotguns are stamped on the barrel to indicate the gauge and the length of the shotshell. The base of the shell case is also commonly marked with the gauge of the cartridge and its manufacturer. Ammunition manufacturers mark the boxes in which they pack their products with the gauge, shot size, powder charge, and shell length. Buy only the gauge and length appropriate for the gun, and the shot size and powder charge suitable for the intended use.

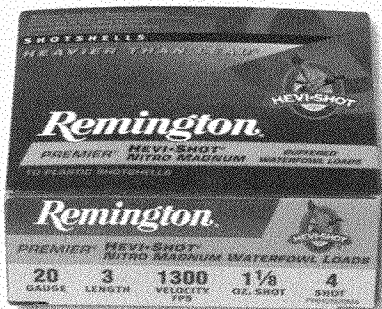

Use the proper gauge of ammunition for your shotgun. Take the time to ensure that the proper gauge is the same on the ammunition box, shells, and shotgun.

## Ammunition Malfunctions

While modern ammunition generally is very reliable, the shooter occasionally may encounter a shotshell malfunction. There are three types of shotshell malfunctions: *hangfire*, *misfire*, and *squib load*.

The waiting time after an apparent misfire is to ensure that you actually have not experienced a **hangfire**—a perceptible delay in the ignition of a shotshell after the firing pin strikes the primer. By keeping the gun pointed in a safe direction, no one will be harmed and no property damaged by the delayed ignition.

A **misfire** is a total failure of the shotshell to fire after the primer has been struck by the firing pin. When the trigger is pulled and nothing happens, keep the shotgun pointed in a safe direction for at least 30 seconds before opening the action.

A **squib load** is the development of less than normal pressure or velocity after ignition of the shotshell. If anything unusual is noticed when a shot is fired, such as a difference in recoil or noise, stop firing immediately. The wad may still be in the barrel. Firing another shotshell in a barrel obstructed by a stuck wad could cause serious injury or damage. Keep the muzzle pointed in a safe direction and unload the gun. Check to be certain that the chamber is empty, then with the action open, check to see that the wad has not remained in the bore. With a break action shotgun you will be able to simply look into the breech end of the barrel. With other action types you will need to run a cleaning rod into the barrel from the muzzle end to assure that the bore is clear. Do not look through the muzzle! If the wad remains in the barrel, push it out with the cleaning rod before reloading.



## The Scout Marksman's Code

A Scout:

- Always follows the rules for firearms safety.
- Accepts the responsibility that goes with the use and possession of firearms.
- Follows the laws that govern the use and possession of firearms in his community.
- Practices wildlife conservation.
- Follows the spirit and the letter of the game laws.
- Is especially careful to be a true sportsman when using firearms.



# Shotgun Safety

In marksmanship, nothing is more important than safety. Participants in shooting sports assume a vital responsibility that affects the lives of others. It is critically important to learn and practice *all* of the shotgun safety rules.

When handled correctly and used properly, a shotgun is not dangerous. A shotgun, like any other precision machine, instrument, or piece of sports equipment, is manufactured to perform a specific task and can do so at no risk to the user or others. If a shotgun is handled incorrectly or recklessly, without regard for the safety rules, then accidents can happen.

Shotgun safety is a simple but ongoing process. You must first acquire knowledge of how to handle shotguns safely, then develop and maintain proper safe-handling skills through practice. The most important element to being safe is attitude. Being safe means consciously keeping the gun under control. Always be alert to, and conscious of, the shotgun's capabilities, and be aware of what might happen if it is used improperly.

Basic gun safety rules fall into two major categories: safe gun handling and safe use and storage.

## Fundamental Rules for Safe Gun Handling

Three basic rules apply to handling a shotgun—under any circumstances.

1. **ALWAYS** keep the gun pointed in a safe direction. Never point the muzzle at yourself or others. Common sense will tell you which direction is safest depending on your location and other conditions. Generally it's safest to point the gun upward or toward the ground.

---

Safety knowledge and skills are of little value without a determination to use them *all* of the time.

---

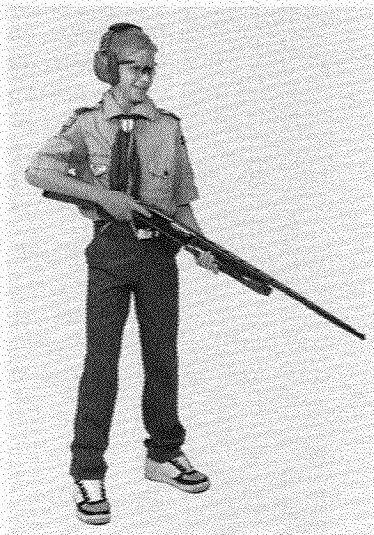

- 2. ALWAYS keep your finger off the trigger until you are ready to shoot.** There's a natural tendency to put your finger on the trigger when picking up or handling a gun. Don't do it! Your gun has a trigger guard. It's there to protect your trigger—to enable you to hold the gun comfortably with your finger off the trigger.



- 3. ALWAYS keep the action open and your gun unloaded until ready to use.** Treat any gun as if it were loaded and ready to go off. Treat every gun as if it were loaded whether at home, on the range, or in the field. This means you never let the gun point at you or anyone else. Whenever you pick up a gun, open the action and check (visually, if possible) to see that the chamber is unloaded. If the gun has a magazine, make sure it's empty. If you don't know how to open the action, leave it alone or get help from someone who's knowledgeable.

Remember, even if you're sure that it's not loaded, always point the gun in a safe direction. By handling unloaded guns in the same manner as loaded ones, you're helping establish sound handling habits and will never have to say, "I thought the gun was empty."



An open, empty gun is safe! Open the action and remove the magazine, or be sure it's empty. Be sure the chamber is empty. Leave the action open. When the gun is in this condition it is safe. But the moment you close the action, you must treat the gun as if it were loaded and ready to fire whether there is ammunition in it or not.

Be aware that removing the magazine from the gun does not unload it! Removing the magazine does not take the cartridge out of the chamber.

## BB and Pellet Air Guns

Air guns are not toys. Today's air gun is a technically sophisticated and precise instrument. Everything in this merit badge pamphlet—on safe gun handling, shooting stance, fundamentals of firing, hygiene, and etiquette—also applies to air guns.

Always wear eye protection when shooting a BB or pellet air gun. Steel BBs can ricochet off wooden or metal target frames, causing injury and property damage. It's best to hang BB targets from a string suspended between two posts, secured at the top and bottom.

Most of this discussion has centered on using the modern cartridge type of firearm. Additional safety rules apply for the muzzleloader. It is loaded by putting a measured amount of powder down the muzzle. The shot is also put through the muzzle on top of a wad that separates the powder and shot. Then another wad is inserted to hold the shot in place.

There's no way your eye can tell whether the muzzleloader is loaded. The best way to determine this is to put the ramrod down through the muzzle when there's no charge in the gun. Mark the ramrod at the muzzle. From this point on, you can tell whether the gun is loaded. Put the gun on half cock and carefully remove the cap if there is one on the nipple. Put the ramrod down through the muzzle until it hits bottom. Check the position of the marking on the ramrod. If the mark is above the muzzle, the gun is loaded.

If your shotgun is a flintlock, remove all powder from the flash pan. This is the powder lighted by the flint flash. Then conduct the ramrod test to see if it is loaded.

## Rules for Using or Storing a Shotgun

When actually engaged in shooting—whether in hunting, recreational practice, or competition—always follow these rules.

- **Know your target and what's beyond.** Be absolutely sure you have identified your target without any doubt. Also be sure of the area beyond your target. This means observing the prospective firing area before you shoot. Never fire in a direction where there are people or where any other potential for mishap might exist. Think first. Shoot second.
- **Know how to use a shotgun safely.** Before handling your gun, learn how it operates. Know its basic parts and how to safely open, load, and close the action, and remove any ammunition from the chamber or magazine if it is loaded.

Remember, a gun's mechanical safety device is never foolproof. The safety device can never replace safe gun handling.

- **Be sure the gun is safe to operate.** Just like other tools, guns need regular maintenance to remain in good working order. Regular cleaning and proper storage are a part of the gun's general upkeep. If there is any question about a gun's ability to function, a qualified gunsmith should look at it. Be especially careful to keep the bore clear of obstructions such as mud, snow, or a stuck wad. Firing a shot in an obstructed barrel can cause the barrel to burst, resulting in severe injury to the shooter and those nearby.
- **Use only the correct ammunition for the gun.** Only cartridges or shells designed for a particular gun can be fired in that gun. Most guns have the cartridge or shell type stamped on the barrel. Ammunition may be identified by information printed on the box and stamped on each cartridge. Do not fire the gun if there's any question about the compatibility of the gun and ammunition.

Carry only one gauge or caliber of ammunition when shooting. Be sure it is right for the shooting you will be doing. You would have trouble hitting a clay target with No. 2 shot instead of No. 9 shot. When you're through shooting, remove unfired ammunition from clothing to avoid accidentally mixing different ammunition the next time you go shooting.

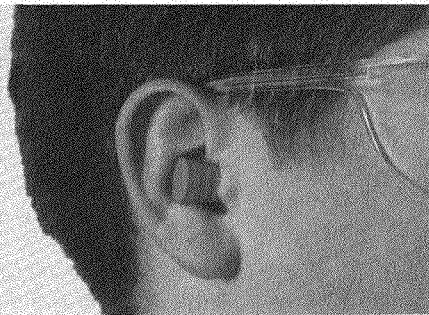

**Always wear hearing and eye protection when you are around firearms.**

- **Wear hearing and eye protection.** Shots fired from guns are loud, and the noise can damage the hearing of shooters and bystanders. Also, debris and hot gases that could cause eye injury are emitted from gunshots. For these reasons, shooters should wear shooting glasses and hearing protection.

—————

If you get into a situation where others refuse to follow the safety rules—do not shoot with them.

—————

- **Never use alcohol or drugs before or while shooting.** Alcohol, or any other substances likely to impair normal mental or physical functions (including prescription and non-prescription medicines), must not be used before or while handling or shooting guns.
- **Store guns so they are not accessible to unauthorized persons.** Deciding where and how to store guns and ammunition depends on several factors, such as security and accessibility. Safe and secure storage requires that untrained individuals (especially children) be denied access to guns and ammunition.

Be aware that certain types of guns and many shooting activities require additional safety precautions. If you plan to go hunting, you will need to learn how to safely carry the shotgun, how to cross obstacles safely, and much more. Remember, when in your home, at the range, or in the field, you alone are responsible for gun safety.

On occasion you may meet experienced shooters who have grown careless, or novices who might be unfamiliar with the safety precautions. A good example of this is the guy who rests the gun muzzle on his toe. This is just plain dumb. Do not be swayed or impressed by such foolishness. Always exercise great caution and responsibility whenever you are handling firearms.

## **Cleaning Your Shotgun**

Your shotgun is a piece of precision equipment. Like any item of value, it must be given proper care if it is to operate correctly and safely. Unlike many items of sports equipment, your shotgun is built to last a lifetime. And it will if you regularly care for it.

Ideally, you should make a habit of cleaning your shotgun each time it is used. Cleaning preserves the finish and value of the shotgun and helps it shoot more accurately and reliably. Cleaning is needed when the shotgun has been stored for an extended period or has been exposed to dirt or moisture. Do not start shooting with a dirty gun. Be sure it is cleaned thoroughly before use.

Before you begin to clean your shotgun, point it in a safe direction, open the action, and **be absolutely sure that the gun is empty and all ammunition is removed from the area.** To ensure absolute safety, always keep the action open during cleaning.

Six basic materials are needed to clean a gun that fires by cartridge or gunpowder. These are:

- **Cleaning rod** with attachments. The attachments must be the proper size for the bore of the gun.
- **Cloth patches**, available commercially or made at home from absorbent cloth, to remove foreign particles from the barrel's interior surface and to apply solvent or lubricant.
- **Bore-cleaning solvent** that dissolves powder residue.
- **Light gun oil** to apply to the moving parts of the gun. Check the manufacturer's recommendation.
- A **clean cloth** to clean the exterior parts of the gun. The cloth should be free of dirt and moisture.
- A **small brush** like a toothbrush for cleaning the smallest parts of your gun.

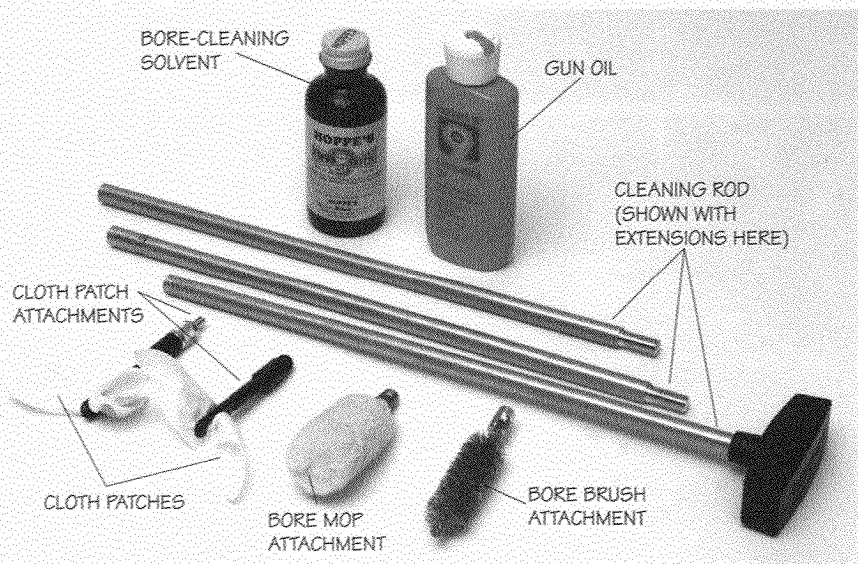

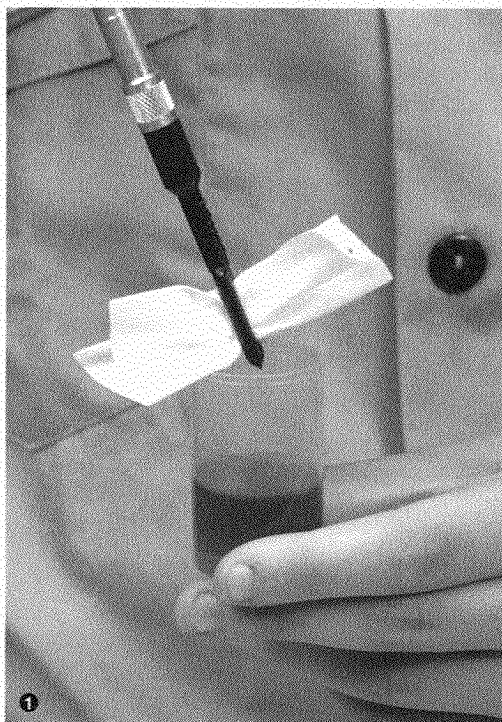

## Steps in Cleaning

**Step 1**—Place a cleaning patch on the cleaning rod, wet with cleaning solvent, and work it back and forth in the bore to loosen residue. If the bore is very dirty, substitute a brass or bronze cleaning brush and repeat the brushing until most of the residue is loosened. Then repeat with a moistened patch. Avoid putting a dirty patch or brush into the main supply of solvent. Use a separate container.

**Step 2**—Thoroughly dry the bore by repeating the above process, using three or four clean, dry patches. Continue until a patch comes through clean after running the length of the barrel.

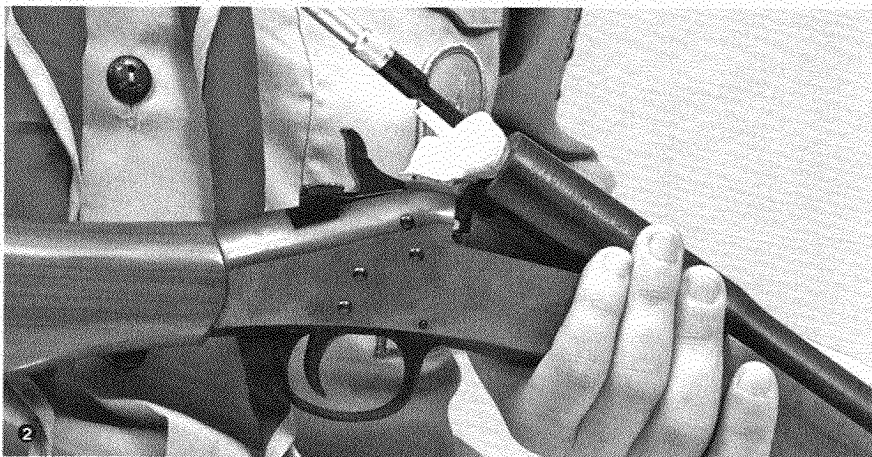





**Step 3**—Wipe all the exterior parts of the gun with a clean cloth, being particularly careful to remove any accumulated grease or dirt from the gun's moving parts. This is where the toothbrush will be needed.



**Step 4**—Check all removable parts of the gun—including stock, screws, magazine, tube cap, and similar parts—to be sure they are all fastened tightly.

**Step 5**—After all the metallic surfaces have been cleaned and dried, protect them during storage by wiping down with a clean cloth lightly moistened with gun oil. Avoid getting oil or solvents on the wood stock or forearm.

## Shooting Hygiene

It is a good practice not to eat or drink when shooting. You should wash your hands and face after you shoot. It is also a good idea to change your clothes if you shoot for hours at a time. If you don't practice good hygiene, you increase your chances of ingesting the lead dust and raising the lead content in your body. On the shooting range, dirt, dust, and the oils from your rifle and ammunition are good reasons for practicing good hygiene and keeping yourself clean. Remember, a Scout is clean.

## Gun Repairs

Do not try to repair any part of your shotgun that appears to be malfunctioning or broken. Even the most minor repairs should be left to an expert; any improper repair could cause your gun to fire improperly or cause further damage—with potentially hazardous results. At the least, you could irreparably damage your shotgun. Don't take chances. Take your shotgun to an experienced *gunsmith* to solve your problem.

## Sensible Storage

Before you decide how and where you will store guns and ammunition, consider safety, storage conditions, access by others, and your personal needs. Many people are intrigued by guns, and the temptation to pick one up is very real for adults and children alike. That could spell trouble if the person is too young or inexperienced to handle the gun safely. Security is another factor. Unfortunately, guns are often desirable booty for thieves.

For all these reasons, it's wise to find a secure and convenient location for your shooting equipment. Many manufacturers offer fine wooden cabinets to display and secure guns. Some gun owners prefer to lock their guns in metal vaults or storage places where they are out of sight and out of reach. If you choose storage that requires a lock, be sure to keep your keys in a place where casual visitors and youngsters are not likely to find them.

Ammunition should be kept in a cool, dry place. Many gun owners prefer to store ammunition separately from guns to minimize the chance of an accident.

## Transporting Your Shotgun

State and local regulations vary. You must make it your business to learn what laws apply where you live, at points in transit, and at your destination. Some places have ordinances restricting firearm transport. Part of your obligation as a responsible shooter is to know and comply with the laws. To obtain information about laws in your area, contact your local law enforcement agency or the National Rifle Association's Grassroots Division of the Institute for Legislative Action.

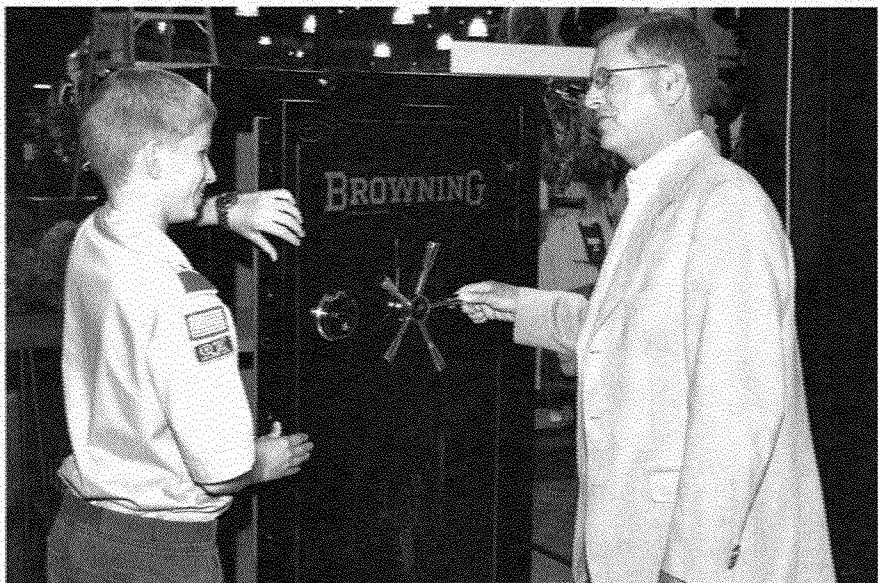

There are many areas of safety and protection not covered in this section. Think about a few examples and what you could do about them. For example, when hunting in the field, you come to a fence. How can you and your gun get safely to the other side? Remember to deactivate your gun as the first step. Open the action and remove all ammunition. Place your gun carefully on the ground under the lower wire or rail of the fence. Then walk to a fencepost away from your gun. Climb the fence and cross to the other side. Then carefully pick up your gun in such a way that the muzzle is never aimed at you. Now you can put the ammunition back in the gun and continue hunting.

# Fundamentals of Shotgun Shooting

Learning to shoot is like mastering any other skill. No first-day skier would venture to the top of the peak for his first run. Nor should you, as a first-time shooter, begin by loading up and blasting away at targets flying in every direction.

Your introduction should start with an understanding of what must be accomplished in the process of learning and using basic skills to hit the target. We'll begin with a discussion of five fundamentals of shotgun shooting that must be practiced and adhered to in exact sequence every time you take a shot. Once you have mastered the fundamentals, you can begin to apply them to a variety of shotgunning sports. The five fundamentals are:

1. Shooting position (stance)
2. Shot preparation (gun-ready position)
3. Swing to target
4. Trigger pull
5. Follow-through

Before you start learning these fundamentals, there's an important question you must answer about yourself. On which side should you shoulder your gun? Whether you are right- or left-handed is not as important as which eye is dominant.

You may not be conscious of it, but you probably have one eye that determines the direction in which you look. That is your dominant eye. Since the ability to align your shotgun with a moving target is essential, you should use your dominant eye and shoulder your gun on that side. How do you determine this? There's an easy test: Extend your hands in front of your

face, placing them together so that only a small opening remains between them. Now look through this space with both eyes open, focusing on some distant object.

While maintaining your focus, keep both eyes open and start moving your hands closer to your face. Continue this motion until your hands reach your face. At this point, you will have instinctively lined up the opening in your hands with one eye. That's your dominant eye. Test a few times to be sure.

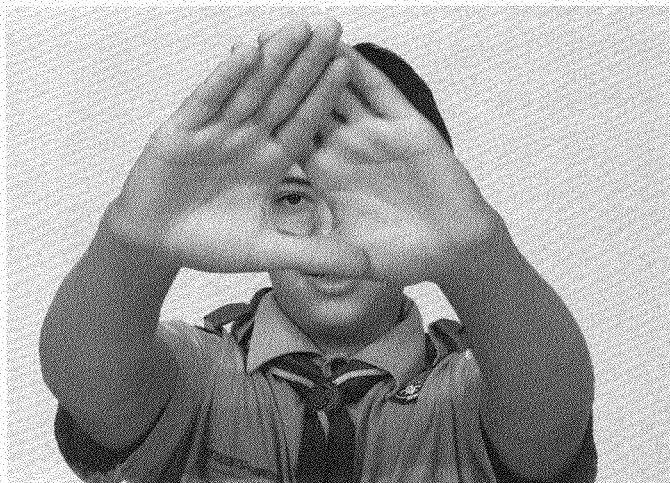

## Shooting Position (Stance)

Almost every shot you will take with a shotgun is from the standing position, so learn it well. Your shooting position must be relaxed and comfortable. This means attaining a stance that's as natural a balance as possible without straining your muscles. Your feet should be about shoulder width apart and planted firmly on the ground. Your front knee should be bent slightly while your back leg remains straight. This position provides proper balance and the ability to move.

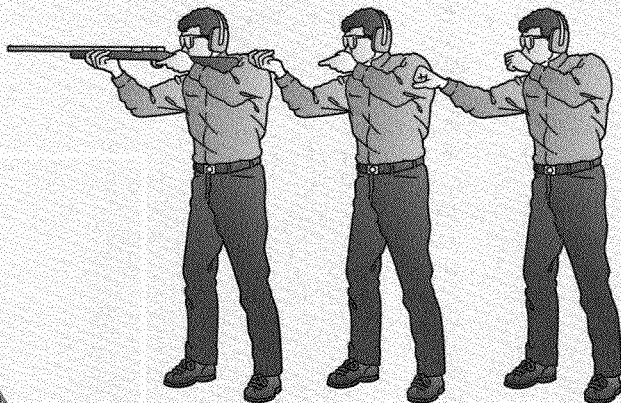

**A good shooting stance is very similar to the basic stance of a boxer (right). With slight adjustment of the hand and arm (middle), the shotgun can be added for a correct shooting position (left).**

Aligning your shooting position with the expected target-breaking area is the second essential consideration. This position will let you easily rotate your body if the target moves to the right or left.

**With a shotgun added, you can move quickly to the target.**



## Shot Preparation (Gun Ready Position)

This is the position you hold while waiting for the target to appear. It is intended to make your swing to the target as easy as possible. Maintain your basic shooting stance. Hold the shotgun with your nontrigger hand at about the middle of the shotgun forearm. Your grip should be firm, but not so tight as to create strain. The same is true of your trigger hand placed on the grip of the stock.



**A gun ready position is relaxed and enhances your ability to see the target area.**

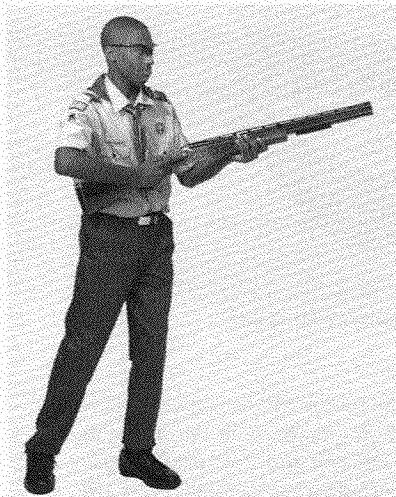

**Place the muzzle just below the anticipated target's flight path to allow a clear view of the target. Keep both eyes open.**

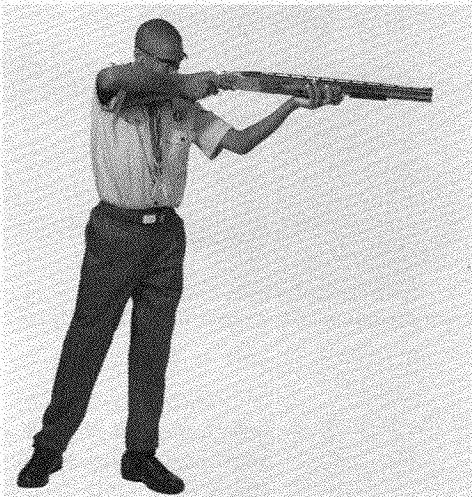

**Mastering proper shot preparation is important before taking your first shot.**

The rear position of the stock is positioned along the front side of your ribs. The muzzle is placed slightly below the expected flight path of the target. This provides a clear view of the target area. Both eyes should be open and focused in the area where you expect the target will first appear.

## Swing to Target

On first seeing the target, move your gun and body as a single coordinated unit toward the target, raising the gun into the correct firing position. To achieve this position:

- Keep your eyes focused on the target all the time.
- Position your face firmly against the stock.
- Bring the trigger hand elbow into position about level with the shoulders.
- Place the butt of the stock against the shoulder.



Keep the comb of the stock firmly in position against your cheek.

With correct gun fit, the barrel will be aligned in front of your dominant eye and with the target. The swing to target must be done quickly, in a smooth and fluid movement. It is important to note that unlike lining up the sights of a rifle, sighting is more of a pointing motion with your shotgun.

## Trigger Pull

Timing and reflex are essential in the act of trigger pull. The trigger pull should take place at the instant when, looking at the moving target, you see your gun's muzzle touch it. Your pull must be quick and crisp, but be careful not to jerk the gun.



## Follow-through

*Follow-through* is one of the most important and difficult aspects of shotgun shooting. Except for targets flying absolutely straight away from the shooter, the shotgun muzzle must move through the target. The trigger is pulled while the shotgun is moving, and the gun must continue to move after the shot is fired. The shotgun must remain welded to your body, especially the cheek. Stopping the motion of the gun after touching the target is the most common cause of misses by beginning shotgunners. Always continue to keep the gun moving by following through.

Knowing the fundamentals is the foundation of successful shooting. Using them correctly and consistently every time provides successful shooting whether you are a beginner or an expert.

## Firing Your First Shots

The steps involved in actual shooting are methodical, progressive, and equally vital. The most effective way to produce the desired results is to be patient and take it a step at a time. Only after proper preparation and review can the shotgun and then the ammunition be added. The rewards will come when you find your shots hitting the target rather than in air.

## Know Your Target

In the exercises to come, you will be building up to your first shots firing on airborne clay targets thrown by a hand or mechanical trap. First, let's look at the target.

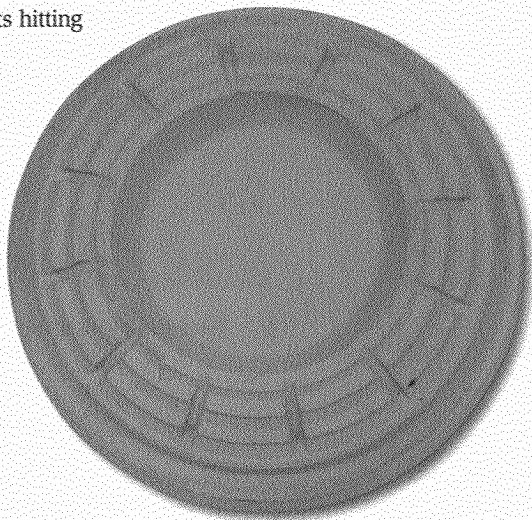

Clay target

The breakable clay target is excellent for learning and is used by millions in target competition. Clay targets are readily available at most sporting goods stores. Some gun clubs and ranges may provide them for their participants. They are easily thrown with a mechanical trap and cost very little.

Learn everything you can about the target. Handle it and see how easily it breaks. Observe how its design facilitates flight much like a plastic flying disc. Watch several in flight. On the range, you will notify the trap operator that you want a target thrown with the command "Pull." Notice how the target emerges from the trap when it is ejected. Get the feel for how fast and where the target flies.

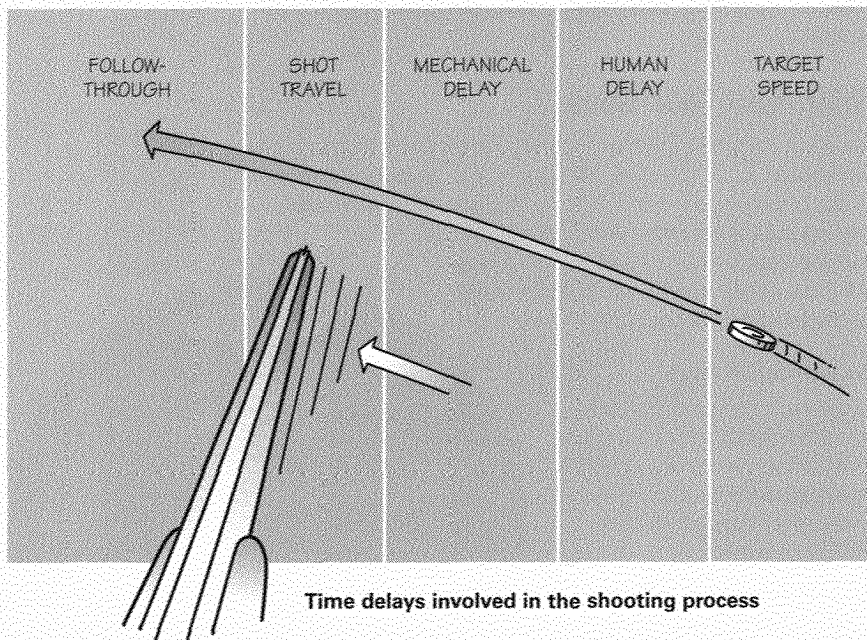

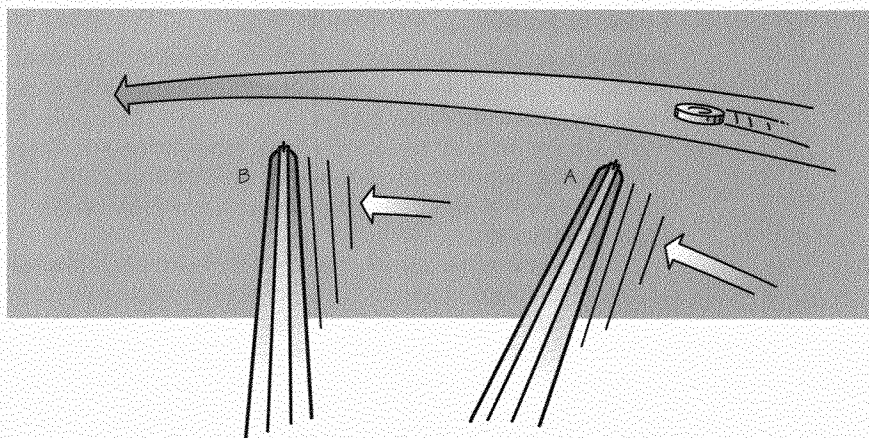

The follow-through shooter gives more lead than he thinks. The gun barrel (A) shows where he thinks he shoots on a crossing target. The barrel (B) is where he really shoots if a good follow-through is used.

### Start With a Straightaway Target

Accomplished shooters fire from many different positions and with targets coming or going from many different directions, angles, speeds, and distances. At the start, you should practice on targets flying in only one direction.

The trap is set so that it will throw the target fairly straightaway in front of you. Initially, each target should follow virtually the same flight path and travel at a relatively slow speed. The background against which the target will be thrown should be clear—an open sky with a low horizon line and no obstructions is ideal. All of this enhances your ability to concentrate and focus on the target—and hit it.

### Learn to Point

Before you actually start working with your shotgun, it is a good idea to run through the fundamentals with a target, using your index finger as a substitute for the shotgun itself. This exercise will teach you to point toward the flying target without having to concentrate on the body movements required to position the shotgun. This will enhance your ability to concentrate on the target at all times.

Assume the proper stance, but with your index finger pointed at a 45-degree angle to the ground. Line up your stance with the expected target-breaking area. If your right eye is dominant, point with the left hand. If your left eye is dominant, point with the right hand. By doing this, when the time comes to add the shotgun, your shooting position will be correct. Now focus your eyes on the area where your target will first appear and call "Pull."



As soon as you see your target, immediately move your finger to the target and keep your finger aligned with it until it hits the ground. Practice this motion several times. Look at the target all the time, not the finger you are pointing with. This is an important concept in shotgun shooting—shotguns are pointed, not aimed. The difference is that your eyes must always remain focused on the target, never on the shotgun barrel or beads.

When you begin to be familiar with this pointing exercise, add a sound effect. When the target is released, again move your finger to it smoothly. At the instant your finger seems to touch the target, simulate pulling the trigger by saying "Bang!" Remember to follow through. This may sound a bit silly, but it serves a distinct purpose. In shotgun shooting, it is imperative

to be able to time your shot so that you pull the trigger as soon as the muzzle seems to touch the target. By saying "Bang," you are learning to recognize and develop a mental picture of actions in shooting that should eventually become instinctive.

### **Practice Pointing With Your Shotgun**

Now you can start using the gun itself. Remember all the basic safety rules. Keep the muzzle pointed in a safe direction and keep your finger off the trigger until you are ready to shoot. Check to make sure both the chamber and the magazine are unloaded by opening the action and making sure no shells are in the gun.

Your first step with the shotgun in your hands should be to review the first three shooting fundamentals. Get into the proper shooting position. Make sure your stance is balanced and allows you to easily rotate from right to left and back, covering the shooting area. Assume the gun ready position. Now practice bringing the shotgun from the gun ready position into the correct firing position. Check to be sure you are doing everything correctly. Take your time, and practice.

Once you have learned to bring the shotgun smoothly into the correct firing position, it is time to add the target. Practice calling for and swinging to the target, following it all the way to the ground. This teaches you to stay with your gun. Be sure to keep your eyes focused on the target all the time.

### **Dry-firing**

After working on the first three fundamentals, you can add *dry-firing*, or pulling the trigger, with the action closed but unloaded. After checking the chamber and magazine, close the action, place the safety in the "off" position, and assume your stance and gun ready position. Now call "Pull," this time pulling the trigger the instant your muzzle sight touches the target.

Now is the time to really work on follow-through. Doing everything exactly the same as when you pulled the trigger, practice staying with the gun for a second or two after firing. Remember to keep the stock firmly in place against your cheek. Open the action after each shot, just as if you were really ejecting a spent shell.

## Shooting Live Ammunition

When you have dry-fired a number of times, it is time to start shooting with live ammunition. First, return your gun to the rack and review the firearm handling and shooting rules. *Make sure you know them and follow them!* Put on your eye and hearing protection. Pick up your shotgun and move to the firing station.

From here on it is a good idea to learn to do each step by the numbers. Learning to do the steps the same way every time is the key to consistent success in shooting. Follow these seven steps:

**Step 1**—Once at the station, your NRA instructor or NRA coach will demonstrate by loading your first shell into the shotgun. (For subsequent shots, the instructor or coach will simply hand you the shell to load.) Place the gun's safety in the "off" position.

**Step 2**—Establish your stance in relation to the target area.

**Step 3**—Establish gun ready position with the muzzle slightly below the target's flight path. Place your finger lightly on the trigger.

**Step 4**—Focus on the target area where the target will appear.

**Step 5**—Call "Pull" for the target.

**Step 6**—Upon seeing the target, swing to target, pull the trigger, and follow through.

**Step 7**—Open the action and unload the shotgun immediately after firing. The action on a semiautomatic shotgun should automatically remain open after the last shot is fired.

How did you do? If you followed the fundamentals, you should have broken a target. If your untouched target dropped to the ground, do not be too hard on yourself. This is just the first shot of many to come. As in all sports requiring skill and coordination, successful shotgun shooting means ongoing practice. So try again! As you refine your ability to concentrate on the target, you will begin to see targets breaking one after another.

Practice with straightaway targets until you hit them fairly consistently. Then you can move on to more difficult targets by gradually changing their angles of flight.



## Choosing a Shotgun

---

Buying quality brands generally will ensure the availability of future repairs and parts. It will help bring a good return on your investment.

---

Getting a shotgun of your own can be something you will remember all of your life. But picking the right one can be tough. Usually, the larger the bore, the heavier the shotgun will be. This makes the .410 shotgun the lightest and the 10-gauge shotgun the heaviest. You certainly will want a shotgun that you are capable of handling and that will do the job for which it is intended. A 12-gauge will give an effective shot density for a beginner and a gas-operated system (autoloader) will reduce recoil. A 20-gauge shotgun of this type can be managed by even the smallest Scouts.

Study available guns in your area. You might start at your local library. A visit to a sporting goods or gun specialty store is a must. Here, you can handle the various guns and test their feel. Find a truly interested salesperson to explain the features of the models you are studying. Be specific about your interests, plans for use, and budget. Take your time. Do not buy on impulse or a slick sales pitch.

### Select a Shotgun That Fits

The main part of a shotgun's fit is in the stock. Most manufacturers sell shotguns with standard stock dimensions designed to fit the average-size adult. Many also produce youth models with smaller or adjustable dimensions suitable to a smaller physique.

There are two important fit considerations—the length from the trigger to the butt, and height of the comb of the stock. For young people or adults with short arms or stature, standard-length stocks usually are too long.



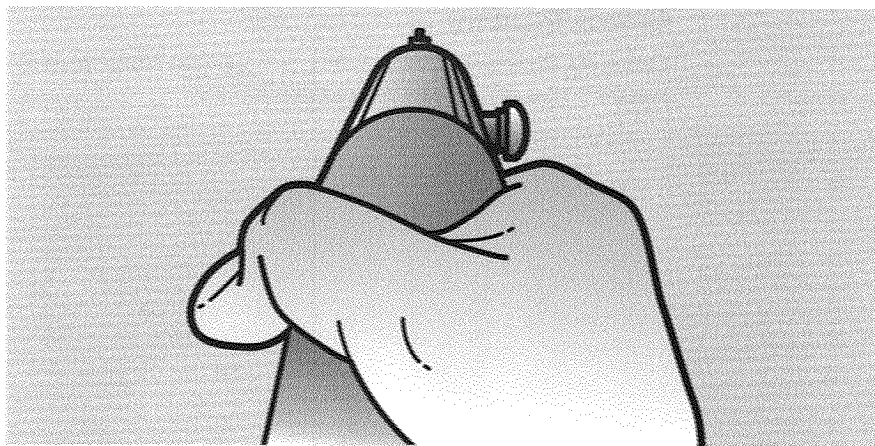

**If the shotgun fits, this is the view you should get when looking down the barrel.**

You should be able to comfortably mount a properly fitted gun in the same place every time. If you find that you are having to make adjustments, the gun does not fit properly. You should try to buy a gun that fits. If you cannot, you may need to have your gun fitted by a gunsmith. Note that as you grow and your shooting skill improves, you may need to have your gun refitted.

When you pull the gun into the shooting position, your cheek should sit tightly against the comb, the barrel should be directly in front of your dominant shooting eye, and there should be approximately 1½ to 3 inches between the end of your nose and the thumb of the grip hand that is wrapped atop the butt grip.

**Some manufacturers make shotguns designed for use from the left shoulder. Make sure the gun is proper for you.**

## Before You Buy

Check out these precautions before making your choice to help you prevent a hasty—and expensive—decision.

### Selecting a Shotgun?

Answering questions like these will help you determine the type of shotgun and ammunition you will need.

- How do you plan to use this shotgun? Will it be used mainly for shooting at clay targets, or will you also want to hunt in the field? What is the best gauge for your use?
- Is ammunition readily available? How much will it cost for the amount of shooting you want to do?
- How much can you spend for a shotgun?
- Have you done your homework? Have you studied manufacturers' catalogs? Have you looked at and handled different makes available?
- Is the shotgun simple to operate and easy to clean?
- Does the gun fit you?
- Have you read the warranty or guarantees?
- Is the shotgun produced by a known manufacturer?
- Does the shotgun brand have a good record for dependability?
- Are you purchasing from a reputable dealer who likely will still be in business when you need help?
- What is the marketability if you decide to sell your shotgun? Could you get back most of your investment if you sell?
- Have you taken your time in making your choice?



## Buying a Used Shotgun

If you are shopping for a used gun, consider these points:

- Locate the previous owner, if possible, and find out why the shotgun was traded or sold.
- A poor outward appearance of a shotgun generally indicates abuse or excessive wear.
- Make certain a refinish job has not disguised past abuse of the shotgun.
- Check screw slots to see that they have not been damaged during disassembly.
- Check the trigger for consistent, safe pull and smooth function. Check the safety to be sure it functions properly.
- Note that shotguns in an original, unaltered condition tend to be of more value.
- Get advice from a gun expert regarding this shotgun's market value.
- Check the wood in the stock for type, quality, and hairline cracks.
- Shoot the shotgun, if possible, before buying.
- Be certain the shotgun is legally owned by the seller.
- You usually get what you pay for! Beware of deals that are too good to be true—they usually are.

**Remember, chances are good that you will keep your shotgun for life.**

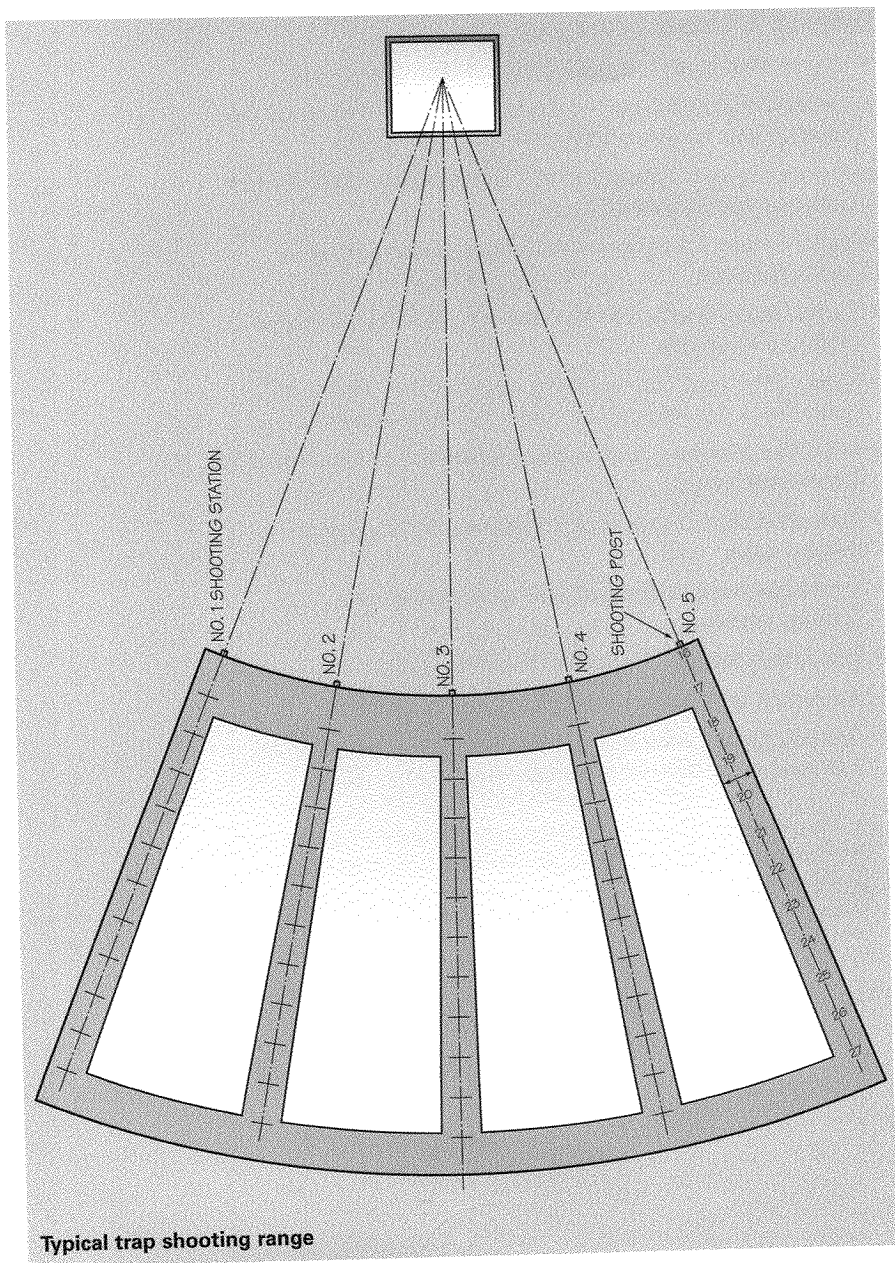

# Clay Target Sports

Many shotgunners enjoy shooting flying clay targets. Some may shoot only at those thrown from a portable or hand trap to sharpen their wing shooting skills for the hunting season. Others enjoy shooting one or more of the clay target sports, either for occasional recreation or as a serious competitor.

The three major clay target sports are trap, skeet, and sporting clays. At least one of these is usually available within a short driving distance from most Scouts' homes in the United States.

## Trapshooting

Trapshooting using live birds released from special "traps" began in Europe around 1790 and in the United States about 1831. Targets began to replace live birds in the mid-1800s.

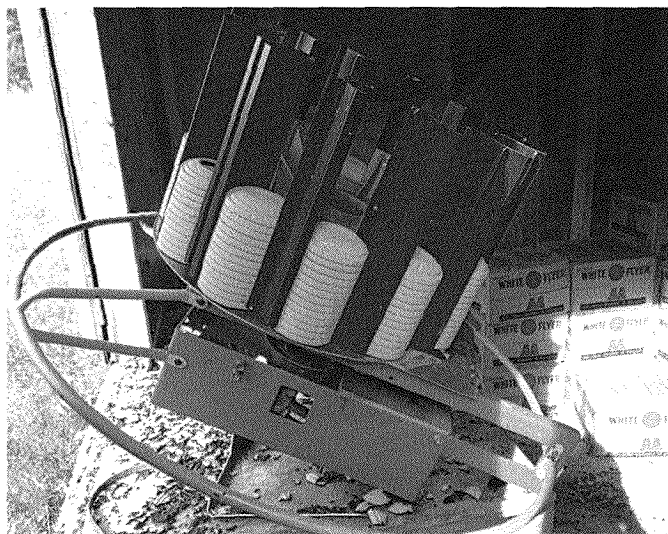

The most popular trapshooting sport is the 16-yard singles event, in which all shooters shoot one target at a time from the 16-yard line stations. Another variation on the event, doubles trap, also is popular. Doubles trap is shot from the 16-yard line and involves two targets being released simultaneously.

The modern field trapshooting consists of five shooting stations located 16 to 27 yards behind a single trap house from which the 4 $\frac{5}{16}$ -inch diameter clay targets are thrown. The targets are thrown going away from the shooter within an area 22 degrees left or right of the trap house center. The shooter knows the elevation of the target's flight, but the horizontal direction constantly varies and is not known until the target emerges from the trap house when the shooter calls "Pull."

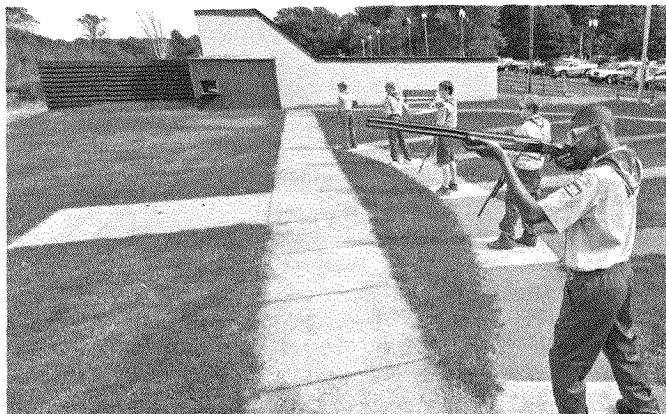

**Trapshooting**

Trapshooters usually use 12 gauge shotguns with modified, improved modified, or full choke barrels and No. 7 $\frac{1}{2}$  or No. 8 shot.

A trapshooting squad usually consists of five shooters, each occupying one of the five stations. Each shooter loads and fires one shot in turn until all have fired five shots, then they rotate to the next station. This process continues until all five shooters have fired five shots from each of the five stations for a total of 25 shots each. The 25 shots by each member of the squad is known as a round of trap. The object is to break all 25 targets, or as many as possible, in the round.

Formal competition trapshooting events are held throughout the United States under the direction of the Amateur Trapshooting Association. The largest of these is the Grand American Trap Shoot held each August. It is the largest shooter participation event in the world. ATA shooters are assigned a classification based on their performance so that each shooter competes against those of their own general skill level.

## Olympic Competition

Olympic trapshooting uses an international form of the sport in which each of the five shooting stations has three associated traps. The targets fly faster than in American trap, and both the vertical and horizontal flight angles vary from shot to shot. Shooters may fire two shots at each target in international trapshooting. USA Shooting is the governing body for the United States' participation in Olympic trapshooting.

## Skeet

The sport of skeet shooting originated in the United States about 1920 as a way for hunters to simulate shots encountered in game bird hunting. It uses the same clay target used in trapshooting.

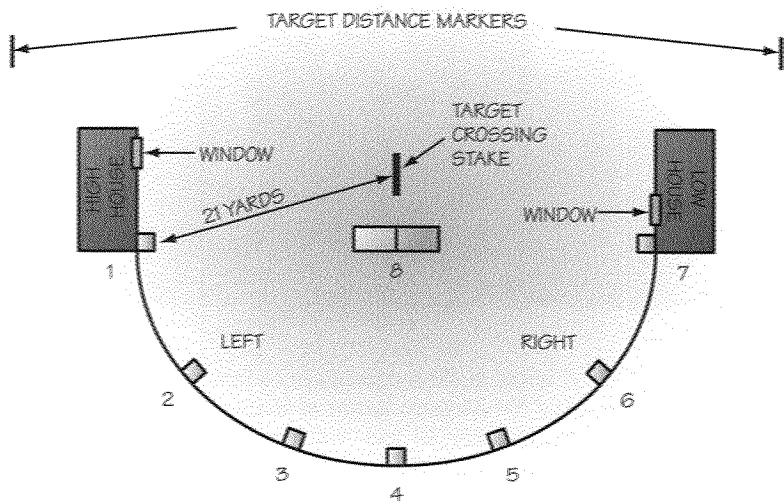

### Skeet shooting range

Skeet is shot on a semicircular skeet field consisting of two trap houses and eight shooting stations. The trap house on the left is known as the *high house*. Targets emerge from the high house 10 feet above ground level. The *low house* is located on the right side of the field. Low house targets emerge 3½ feet above ground level. Targets from either house are thrown to pass 15 feet above ground level over the *crossing stake* located at the center of the semicircular field.

Seven of the eight shooting stations are distributed evenly around the outer perimeter of the skeet field with station one at the high house and station seven at the low house. Each of these seven stations is 21 yards from the crossing stake. Station eight is located halfway along a line between the two trap houses.



**Skeet shooting**

A round of skeet consists of 25 targets. The typical skeet squad of five shooters begins at station one and progresses through station eight with each shooter, in turn, completing all of the shots required at each station before moving to the next station. A single target from the high house is the first shot at each station and is thrown when the shooter calls "Pull." That is followed by a single target from the low house when the shooter again calls "Pull." Doubles skeet is shot from stations one, two, six, and seven. In shooting doubles, the shooter loads two shotshells and calls "Pull," and the two targets are thrown simultaneously, one from each trap house. The shooter must shoot the "going away" target first and the "incoming" target second. Doubles are shot immediately following the two single targets at the four stations where they are required. At station eight the entire squad takes their turn at the high house target only. Then they each shoot the low house target.



If you've been counting, you have noticed that this accounts for only 24 shots. In skeet, the remaining shot is either a repeat of the shooter's first missed target or, if all 24 targets have been broken, a repeat of the last shot at station eight low house.

Skeet may be shot with any gauge shotgun, 12 gauge or smaller, capable of firing two shots in quick succession. Since it is a close-range sport, guns with skeet or improved cylinder chokes using No. 9 shot are preferred.

Formal competitive skeet shooting events are held throughout the United States under the direction of the National Skeet Shooting Association. Most formal competitions have separate events for the 12 gauge, 20 gauge, 28 gauge, and .410 bore shotguns. Shooters are assigned classifications based on past performance so that they may compete with those of similar ability. The largest tournament is the World Skeet Shooting Championships held each October in San Antonio, Texas.

International skeet is shot in many other countries and as an Olympic sport. While it uses the same field layout as American skeet, the targets are thrown faster and their release is randomly delayed up to three seconds after the shooter calls "Pull." Further, the shooter must hold the shotgun butt at hip level until the target emerges. Moving the shotgun before the target is released is scored as a lost target. To add even more challenge, some of the easier targets in American skeet are eliminated and doubles as well as singles are required on stations three, four, and five. USA Shooting is the governing body for the United States' participation in Olympic skeet.

**The shooting sports are able to accommodate the highest levels of physical disability of any of the skill ports. Modern adaptive equipment and positioning techniques allow people with a variety of disabilities to have a safe and enjoyable experience in many types of shooting activities.**

## Sporting Clays

Sporting clays originated in France in the 1920s. It was introduced in the United States in the 1960s and has been growing rapidly in popularity since 1990.

Sporting clays courses offer a wide variety of shots that simulate those found in hunting upland birds, waterfowl, and rabbits. Each sporting clays course is unique and presents a mix of close, midrange, and distant shots traveling at various speeds from several traps. In addition to the standard clay target used in skeet and trap, sporting clays shooters are also challenged with the 90-millimeter mini target, the 60-millimeter mini target, the nearly flat ( $\frac{1}{4}$  inch thick) battue target that may show only its narrow edge until it turns in flight, and the rabbit target, a tough version of the standard target that bounces along the ground like its namesake.

Both single-target shots and doubles are encountered in sporting clays. Doubles may be thrown simultaneously from two traps, as following pairs released in quick succession (but not simultaneously) from one or two traps, or as report pairs where the second target is thrown as soon as the first target is fired upon.

Shooters on a sporting clays squad progress from station to station throughout the course. At each station the squad is first shown the flight of the targets they are about to shoot. Each station may have safety barriers on either side of the shooter to prevent unsafe shooting to the left or right. Sporting clays courses often are built in wooded areas that present the shooter with very limited spaces in which to shoot the target. A sporting clays event usually consists of 50 or 100 targets. Perfect scores are rare!

Because of the variety of distances at which targets must be shot, sporting clays shooters usually use shotguns with changeable or adjustable chokes. The over-and-under shotgun is often preferred since it gives the shooter the opportunity to quickly select two different chokes while shooting. Most sporting clays participants use a 12 gauge shotgun, although special events are frequently held for smaller gauges. Shot sizes used range from No.  $7\frac{1}{2}$  to No. 9, depending on the type and distance of the target to be shot.

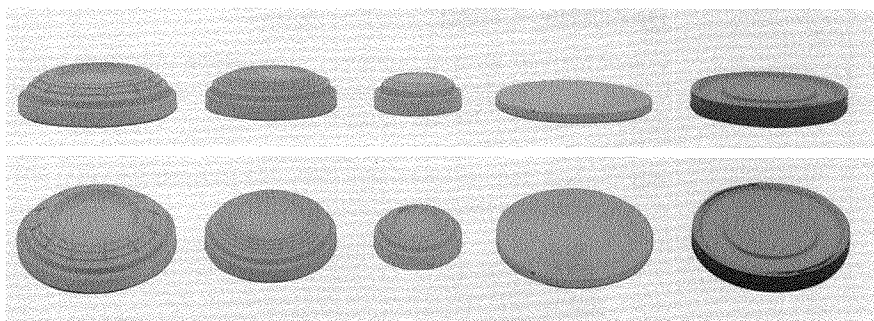

Common clay targets, from left: standard trap and skeet target, midi target, mini target, battue target, rabbit target



Sporting clays shooting

Formal sporting clays competitions in the United States are held under the direction of the National Sporting Clays Association. Classifications are assigned to the shooters based on their past performance so that each competes against those of like ability.

## Shooting Clubs

One of the best ways to improve your shooting skills is to join a local shooting club and its junior shooting program. Juniors in these clubs shoot the NRA Qualification Program and participate in local, state, and national competitions. A local club is a great way to meet new shooters with the same interests and to travel to new places to test your shooting skills.

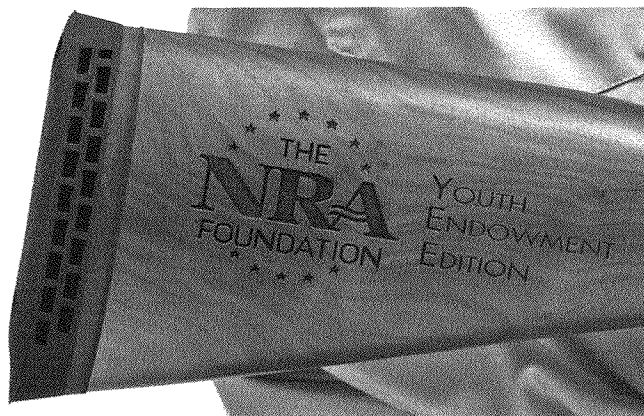

## Special Activities

**NRA Youth Hunter Education Challenge (YHEC) programs** are sanctioned each year in the United States and Canada by the hunter safety coordinator in each state or province. The top finishers from these events are eligible to participate in the North American YHEC, which is held each summer. Young hunters also have the opportunity to earn awards for successful hunts in the Young Hunter Awards Program.

Camp programs offer one way to introduce young people to shooting. Not only do BSA local councils have shooting in many of their summer camp programs, but many private summer camps also have shooting programs.

School programs are designed to educate high school students about shooting sports and to promote activities among school groups. Physical education classes, scholastic clubs, and competitive teams may be involved in any of the various shooting disciplines.



## Collegiate Clay Target Shooting

More than 50 colleges and universities have some form of shotgun shooting program. A few of these schools offer shooting scholarships. The Association of College Unions International, with assistance from the National Rifle Association, conducts the annual Intercollegiate Clay Target Championships. Every classified collegiate shotgunner in good standing is eligible to compete, and participation is on the rise.



# Muzzleloading Shotguns

Until the introduction of cartridge firearms in the 1800s, all firearms were muzzleloaders. The firearm originated more than 500 years ago. Its inventors found that when a highly combustible material was confined and then lighted, the resulting burning or explosion created enough energy to send a projectile over long distances.

The earliest firearms were incredibly crude and unpredictable by today's standards. Since their inception, firearms have consisted of three basic parts: the *lock* (or firing mechanism known today as the action), the stock (the handle by which the gun is held), and the barrel (the hollow tube through which the projectile travels on its way to the target).

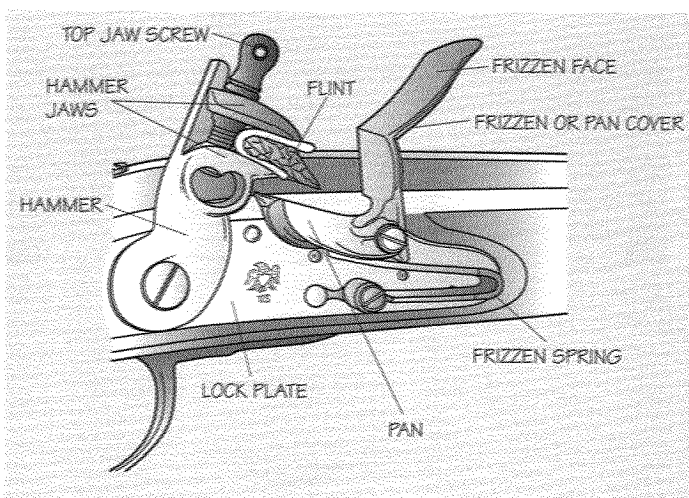

**Flintlock action**

The term muzzleloader comes from the fact that all of these guns were loaded through the muzzle. First came the *matchlock*, a gun fired by a lighted wick that ignited the powder. This was followed by the *wheel lock*. This gun's powder was ignited by a spark that came from a wheel spinning against flint. Then came the *flintlock* and the *percussion lock*—the two that are considered in this merit badge pamphlet.

The flintlock was developed in the 1600s. A piece of flint was secured between the jaws of the *cock*, or *hammer*. The *priming powder* was contained in a pan, covered by a hinged lid called the *pan cover* or *frizzen*. When the trigger was pulled, the flint struck the frizzen. As the flint scraped the frizzen face, sparks flew into the priming charge in the pan.

The final advance in the history of the muzzleloader took place in the early 1800s. During this era, a compound called fulminate of mercury began to replace powder as the priming agent. This compound was housed in a small metal container known as a *percussion cap*. When the cap was struck by the hammer of the gun, it ignited, setting off the powder charge. Percussion caps were the forerunner of the modern cartridge. They represented the first use of a prepackaged priming agent in the firing mechanism.

The matchlock and wheel lock muzzleloaders are found today only in museums or in the hands of collectors. The flintlock and the percussion lock are alive and well. The popularity of these two guns is great enough for manufacturers to make replicas that can be found in sporting goods stores.



## Parts of the Muzzleloading Shotgun

In today's language, the expression "lock, stock, and barrel" means the job is finished. Actually, this old expression describes the parts of a muzzleloader.

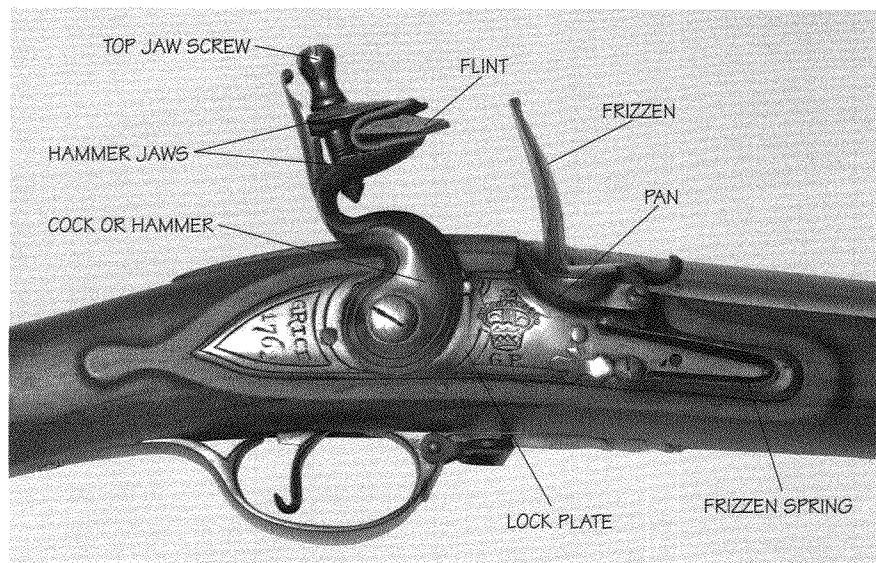

### Parts of the flintlock

#### The Lock

This is the portion of the gun used to ignite the main charge in the barrel. The lock will differ depending on whether it is for flintlock or percussion lock. In the flintlock, certain steps must be taken to ensure that the flint can function properly. The jaws of the hammer on these firearms generally uses a bed of leather that holds the flint firmly. In positioning the flint, you must not allow the front edge to touch the closed frizzen when the hammer is in the half-cock position. The position you select for inserting the flint will depend on what works best with your gun. The bevel (slant) of the flint may be either up or down—whichever is more successful.

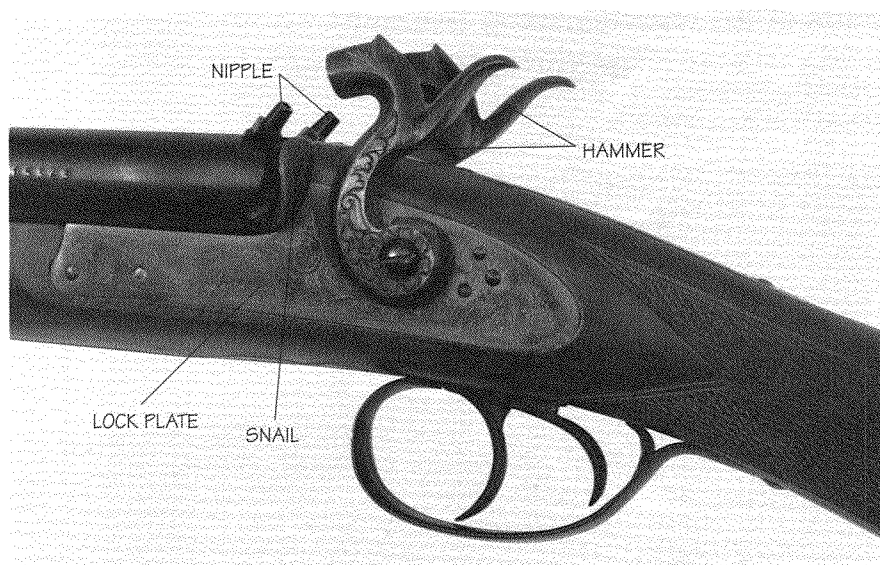

### Parts of the percussion lock

The action of pulling the trigger trips the lock. In this process, the hammer comes down briskly, striking the face of the frizzen or percussion cap and setting off the ignition necessary to fire the main powder charge. The percussion gun has a small cap that can be fitted over the nipple. When the hammer strikes the cap, it detonates, sending the ignition down to the main powder charge. It is important that you understand the workings of the mechanism for either gun, since this knowledge will be helpful in caring for and cleaning your gun.

### The Stock

This is the part by which the gun is held. It is particularly important in muzzleloading guns. Shotguns fire with some recoil, or kick. Thus the butt must be designed so that it fits snugly against your shoulder to absorb these forces. The end of the stock that makes contact with your shoulder is called the butt. The top portion of the butt is called the heel, and the bottom portion the toe.

Aiming the shotgun also brings the stock into play. Since the sighting features on a shotgun are quite basic, bringing the gun into position where the eye has a clear view of the target and its projected path is essential. In such a position the shooter's cheek touches the stock in a top area known as the comb. The "fit" of a shotgun stock to a particular shooter is an essential part of accurate shooting.

The stock must be designed to allow the shooter to grip the entire gun firmly. The portion of the stock grasped by the hand in order to pull the trigger is known, appropriately, as the grip. Yet another purpose of the stock is to provide a firm support for the barrel. The part of the stock extending under the barrel is known as the fore-end.

### The Barrel

Shotgun barrels have a smooth bore. The diameter of shotgun bores commonly varies from  $\frac{1}{2}$  inch to more than  $\frac{3}{4}$  inch. The term used to describe the bore of a shotgun is called the gauge. The most common bore sizes of muzzleloading shotguns are 10, 12, 16, 20, and 28 gauge.

Unlike breech-loading shotguns, most muzzleloading shotguns have little or no choke. Choke is the term used to describe the narrowing of the barrel at the last few inches nearest the muzzle. The more the barrel is choked, the less the pattern spreads.

Choke is unusual in muzzleloading shotguns because the smaller choked portion makes it difficult to load a bore-size wad through the muzzle. As a result, muzzleloading shot patterns tend to be wider than those of most breech-loading guns.

Because muzzleloaders spread shot wider than other shotguns, they generally are used more for hunting or shooting moving targets. The sighting apparatus tends to be simple. Muzzleloading shotguns usually have a small bead attached to the top of the barrel at the muzzle end. The shooter's eye then serves as the rear sight, so proper positioning of the stock while shooting is vital.

---

A shotgun  
is pointed,  
not aimed.

---

## Using Black Powder

True *black powder* is essentially the same substance that has been used as ammunition in muzzleloaders for centuries. It's a mixture of saltpeter (potassium nitrate), charcoal, and sulfur that, when burned, emits a dense cloud of white smoke. It was developed as a propellant in rock throwing around A.D. 1200 and has remained essentially unchanged.

Only commercially manufactured, sporting-grade black powder or black powder substitute offered for sale by a reputable firm should be used in muzzleloading rifles. Black powder substitutes produce nearly identical pressure, bullet velocity, smoke, and noise.

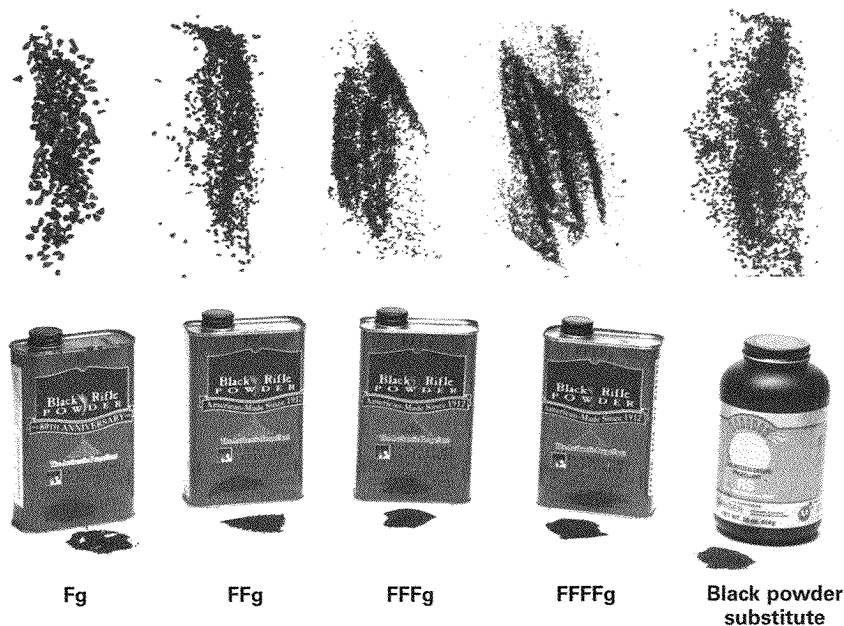

Black powder usable in muzzleloading firearms can be found in four granulations. The grain size of the powder will determine its rate of burning. The finer the grain, the faster the powder will burn and, therefore, the greater the pressure it will develop. Under containment this pressure increases greatly. The very finest black powder should never be used as the main charge.

The four basic granulations are:

- **Fg** Course-grain powder, which may be used in shotguns of 10 gauge and larger.
- **FFg** Medium-grain powder used in shotguns of 10 to 20 gauge.
- **FFFg** Fine-grained powder used in shotguns smaller than 20 gauge.
- **FFFFg** This extra-fine-grain powder should be used only as a priming agent (never as the main powder charge).

Black powder substitute is available from a number of sources. Its chemical makeup is different from that of black powder, but it will produce about the same pressure, shot velocity, smoke, and noise as black powder. A substitute is not recommended for use with flintlocks, and loading procedures for substitutes may vary. Your gun dealer or manufacturer should be able to provide details.



Whether you are using black powder or a substitute, you must exercise proper safety. Both are explosives, and as such are subject to rapid and unexpected ignition unless handled with utmost caution. Check local ordinances pertaining to the storage of explosives of this

nature. Laws vary, and you have full responsibility to respect and obey whatever conditions are applicable in your community. When using black powder or a substitute:

- Always store in a safe container. Black powder usually comes in a 1-pound metal can, which protects the powder against sparks and heat. Make sure the can is firmly sealed when not in use. Never store black powder in a glass or plastic container.
- Always handle powder in an open, well-ventilated area. In the process of pouring powder in the powder horn or flask you use for transporting in the field, you can accumulate fine powder dust that can easily ignite if put in contact with a spark, flame, or heat.
- Never let anyone smoke around you when handling powder.
- Always use powder measures when placing powder in your gun. Never pour powder directly from the can, horn, or flask, as there could be a spark remaining in the barrel from a previous shot. This could ignite your entire powder supply.
- Always store powder separately from percussion caps.

## Loading Your Muzzleloading Shotgun

Loading may seem complicated and time-consuming, but remember that you are repeating a generations-old process. With repeated practice, you will get the hang of it.

Loading requires several accessories:

- **Powder horn or flask.** This is the receptacle for carrying powder in the field.
- **Powder measure.** This small container is used to determine the proper amount of powder for each shot and to pour it into the muzzle of the shotgun.
- **Wads.** These fiber spacers are used to form a seal between the powder and shot in the barrel and to retain the load position in the barrel.
- **Wad lubricant.** This substance is used to lubricate the wads, therefore assuring more effective sealing and some softening of residues that naturally accumulate in the barrel when the gun is fired.
- **Wad puller.** This instrument is used to remove wads from the barrel in cases where some malfunction prevents the shot from being fired.
- **Ramrod with cleaning jag.** A standard feature on most muzzleloading firearms, the ramrod is used to push the charge into the barrel. When used with a cleaning jag, it is useful in cleaning the inside of the barrel.
- **Cleaning patches.** Pieces of soft fabric are used to wipe the bore and other hard-to-reach portions of the gun.
- **Vent pick.** This is a thin wire used to clean the flash channel.
- **Nipple wrench.** This small wrench is used to remove the *nipple* of muzzleloading percussion shotguns.
- **Shotgun mop.** This is a handy tool for cleaning and lubricating the bore.
- **Shooting box or hunting pouch.** This is a container for holding all of these items, in addition to your shot, priming powder container (if using a flintlock), and other gear you might find useful.



Items needed for shooting muzzleloading shotguns, identified by number: (1) wad lubricant, (2) wad puller, (3) cleaning patches, (4) vent pick, (5) nipple wrench, (6) shotgun mop, (7) hunting pouch, (8) ear protection, (9) shooting glasses, (10) powder flask, (11) shot flask, (12) shot pouch, (13) shot measure, (14) wads (over powder), (15) wads (filler), (16) wads (over shot), (17) powder horn, (18) percussion caps, (19) powder measure, (20) cleaning rod

Before you begin to absorb the loading directions, a few cautions:



- Always wear eye protection when loading or firing your gun.
- Always wear hearing protection when any firing is done.
- Always follow the loading procedures in the exact order you read them here!



Place the shotgun between the legs for loading. This is a common and stable position.

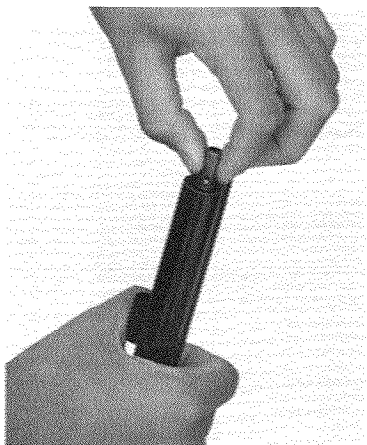

### Position the Shotgun for Loading

If you are loading a double-barrel shotgun, you must be very cautious at the beginning. In the case of a percussion gun, if one barrel is still loaded, make sure its nipple is uncapped and the hammer is at half-cock position. If it's a flintlock, be sure the priming pan is empty, the frizzen open, and the hammer down. Also be careful that you load the empty barrel! It's easy to make a mistake and double the load in one barrel if you are not paying close attention.

Once you've taken these precautions, stand the gun on the ground with the firearm resting between your legs and the muzzle pointed upward and away from you. Never work directly over the muzzle of a shotgun, even when you're sure the gun is unloaded.

### Check Bore for Load

It's easy to check the bore for a load. When you are certain the gun is empty, take the ramrod from the stock and insert it as far as it will go into the barrel or use a *bench rod*. A bench rod is a ramrod made of brass, stainless steel, or other unbreakable material, with a large handle. Using a bench rod when target shooting is more comfortable for the shooter, and it is less likely to break than a wooden rod. Mark a spot on the ramrod flush with the muzzle. Whenever you want to check whether there's a load in the shotgun, put the ramrod down the barrel. If the mark you made when the gun was empty is at muzzle, the barrel is empty.

Never try to clear a loaded or obstructed barrel by yourself. Enlist the aid of an experienced shooter, or, better still, a qualified gunsmith. Never try to free the gun of an old load by firing. You don't know how long the load has been sitting there, what it consists of, or what will happen when you try to fire.

**Insert the ramrod to check the bore for a charge. The bottom part of the ramrod should come to the nipple.**



## Wipe and Clean the Bore

Wipe and clean the bore. Use your ramrod to run a dry shotgun mop or cleaning patch up and down the bore. This will remove any excess oil from the bore that might interfere with ignition. On a flintlock, you can run a vent pick through the flash hole. Also, clean around the pan and frizzen with a brush or cloth to remove oil, dirt, and lint.

With a percussion shotgun, you will want to clear the flash channel by firing two or three percussion caps on the nipple. To do this, step up to the firing line. Place a percussion cap on the nipple. Point the shotgun downrange and fire the first cap to ensure the barrel is empty. Place a second percussion cap on the nipple and point the shotgun at a leaf on the ground or blade of grass in front of the firing line. Fire the cap and look to see if the leaf or grass moves, and repeat if necessary. If the leaf or grass moves upon firing, you are assured the flash channel is open.

Once you fire the percussion caps or pick the vent (flintlock), you are now ready to take a blow-out shot. To "blow out" the barrels, pour powder from the horn or flask and fill the powder measure to the correct level. Pour the powder into the barrel from the measure. Insert an over powder card wad, which is a stiff card, approximately .125 inches thick, into the barrel and push it all the way into the barrel until it is tightly against the powder charge. Take the shotgun to the firing line or designated blow-out area. Place a cap on the nipple or pour priming powder into the pan, and point the shotgun safely downrange. Fire the shotgun downrange. This process ensures all the excess oil is out of the barrel and you are ready to shoot your targets.

## Measure the Powder Charge

Pour powder from your horn or flask and fill the powder measure to the correct level. A good starting measurement for 12 gauge is the 1-ounce measurement on the dipper, filled with powder. This is approximately 65 grains. However, always follow the powder charge recommendations that are provided by the manufacturer.

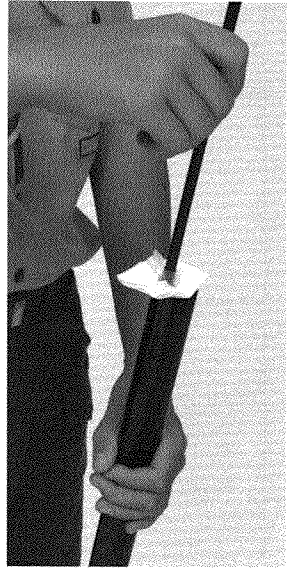

**Use a cloth patch to remove any dirt and residue from the bore.**

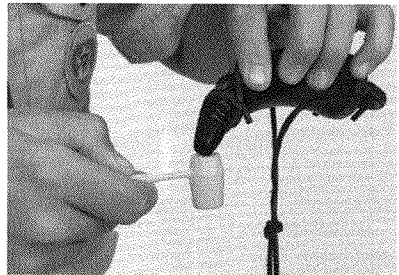

**Always use a powder measure in the loading process. Never load a gun directly from the powder flask.**

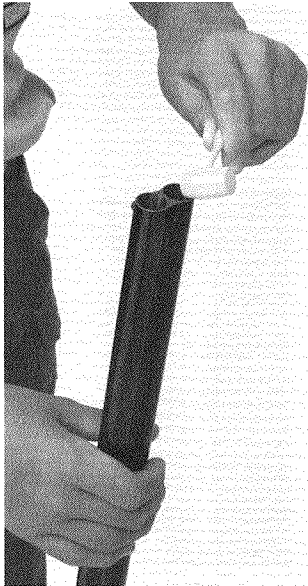

**Pour the premeasured charge directly from the powder measure.**

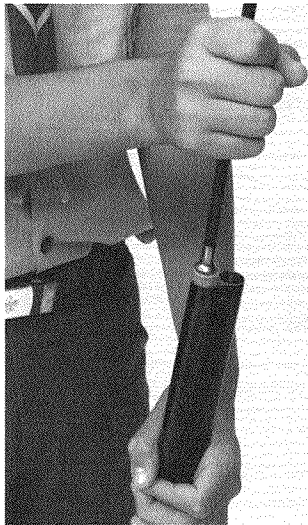

**Seat the wad as shown.**

### Charge the Barrel With Powder

Being careful to keep the muzzle pointed away from you, pour the powder from your powder measure down the barrel. Tap the side of the barrel a few times with the heel of your hand to shake the powder clinging to the sides of the bore. If using a double-barrel shotgun, remember to keep track of which barrel you load first to prevent double loading the same barrel. One way to do this is to leave the ramrod in the barrel you are *not* loading while you are loading the other barrel.

**Remember, never pour powder directly from the powder can, powder horn, or flask.**

### Load the Wad Column

The next step involves inserting and securing the first two of three wads you will use in preparing the charge. First place an “over powder card wad” (with a thickness of about .125 inch) over the muzzle. Use of a short starter may help get the over powder wad started in a choked shotgun. Push your ramrod all the way down the barrel so that the wad reaches the powder. The large button at the end of the ramrod will straighten the wad as it’s rammed into the barrel. When you’ve rammed far enough to reach the powder charge, apply and maintain a little pressure to compress the wad and the powder together. Holding the wad against the powder for a moment will minimize the chances of air pressure building up between the wad and the powder and creating a gap between the two. If you feel air pressure force the wad and ramrod up, push down again until the air trapped behind the wad bleeds out.

Once the wad is firmly seated, follow it with a thick ( $\frac{1}{4}$  inch or more) fiber wad. This second wad should be dampened—but not saturated—with a good black powder lubricant before insertion. Again, be sure that this second wad is seated against the first and that both are tight against the powder charge.

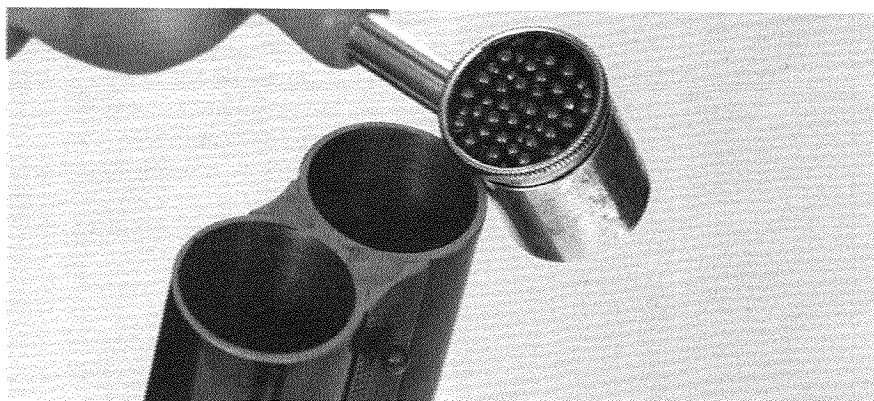

Using a shot measure expedites the loading process.

### Load the Shot

Before inserting the shot, determine what shot is to be used. For trap shooting, No. 7½ or 8, and for skeet shooting, No. 7½ to 9 shot are acceptable sizes. Hunting will require a size ranging from No. 2 to No. 8, depending on the game you'll be hunting. The charge can be measured by using a shot dipper or a flask with a built-in measure. Once the proper charge has been measured out, pour it down the bore. A good rule of thumb for a starting load of shot is equal volumes of shot and powder. So, if the dipper is set at the 1-ounce measurement, you can use a 1-ounce shot. If the gun recoils uncomfortably, you can reduce the shot and powder load.

### Load the Over-Shot Wad

Finally, take a thin wad and insert it down the barrel as before. Make sure the wad is firmly seated against the shot. Be careful not to apply excessive force as this will deform the soft shot and create an erratic shot pattern when the gun is fired.

After the final wad is firmly seated, again mark the ramrod flush with the muzzle. This will give you a reference to use in future loading so that you will know that the charge and wads are seated correctly each time you load. Note that you have two marks on your ramrod—one to show the depth of the rod when the barrel is empty, and the second to show the depth when loaded.

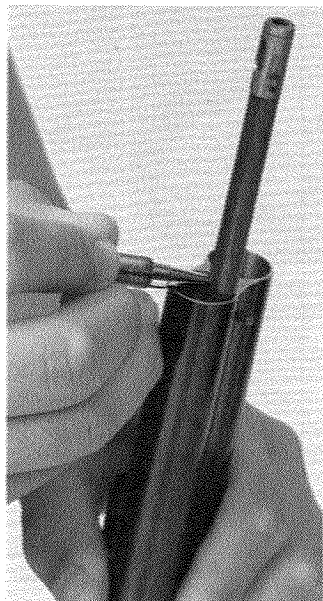

Once your shotgun is loaded, it's a good idea to mark the ramrod for future reference.



The final step before firing is capping the nipple.

### Capping or Priming

The final step before firing is applying the percussion cap, in the case of a percussion gun, and bringing the hammer to full cock. In the case of a flintlock, fill the priming pan one-half to three-quarters full of fine-grain black powder (such as 4f). Close the frizzen and bring the hammer to full cock. You are now ready to shoot.

### Failure to Fire

You pull the trigger, and nothing happens. The main charge doesn't fire—a misfire. Don't give up. There are a few relatively easy troubleshooting steps you can run through quickly that could solve your problem.

The first thing to remember when you have a misfire is to keep the gun at your shoulder for a couple of minutes, pointed safely downrange. On rare occasions, muzzleloading shotguns can have a hangfire—a delay between the time the trigger is pulled and the time the gun goes off, caused by a slow-to-ignite powder charge.

After waiting that couple of minutes, unshoulder your gun and run a pipe cleaner or fine wire through the nipple or flash hole (on a flintlock) to be sure the channel is open. Recap, or in the case of a flintlock reprime, and try again.

If the gun still will not fire, the problem could be that no powder rests behind the shot. You may have forgotten it during the loading sequence. If you're using a percussion gun, remove the nipple with your nipple wrench. On a flintlock, you can sometimes work sufficient powder behind the charge through the firehole. Cap or prime and try to fire again.

Still no luck? After a reasonable number of corrective efforts, your best course of action is to use a carbon dioxide discharger to expel the load. The other option is to pull the charge. For this you'll need a strong, sturdy tool. Your standard ramrod may be too delicate or too short to do the job easily. You'll need a stronger, more durable tool, called the *bench rod*. It's best if this rod has a handle to provide additional leverage. The bench rod also can be useful in cleaning and loading.

After making sure that your gun is uncapped or unprimed, screw a wad puller onto the end of your bench rod. This tool is designed to screw into the wad and give a turning motion. Insert your rod down the bore and gently screw the wad puller into the top over-shot wad. Bring out the rod and dispose of the wad. Now pour out the shot and retrieve the two remaining wads with the wad puller, one wad at a time. Pour out any powder in the barrel. Thoroughly clean the barrel and flash channel, or nipple, before reloading.

With a flintlock, failure to fire could be caused by a dull piece of flint. Your best bet is to replace the flint with a new piece. To replace the flint, use a large screwdriver to open the jaws. Remove the old flint and place a new one between the jaws and retighten the screw. *Be careful handling flints, as they are extremely sharp!* When changing the flint, the priming pan should be empty and the frizzen up. If you must replace the flint with a charge in the barrel, have the instructor blow the load with a CO<sub>2</sub> discharger first. Do not return a loaded gun to the loading area. Ask for assistance.

The remaining failure type is the squib load, when insufficient power fails to expel all of the wads from the barrel. It will be necessary to clear the bore before the gun can be successfully reloaded. Squib loads may be signaled by an abnormally soft recoil or light report on firing.

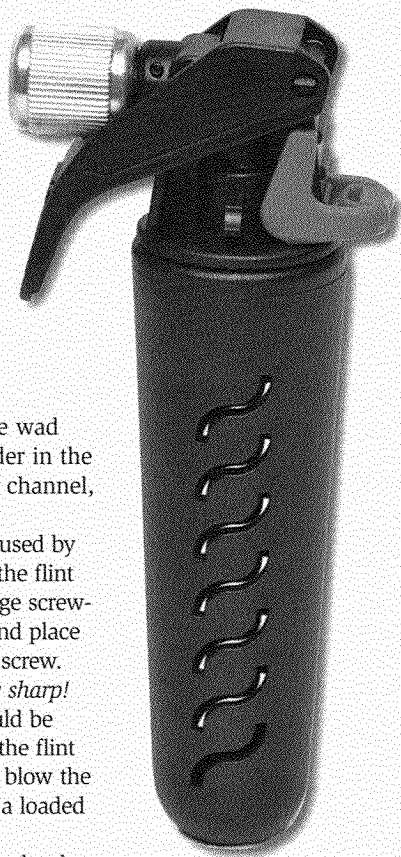

**Carbon dioxide discharger**

The wad puller is also useful in retrieving cleaning patches that may have fallen off the cleaning jag.

## Taking Care of Your Gun

A lot of the information in the chapter titled “Shotgun Safety” applies to the care of your muzzleloader. However, there are a few differences, and you should note them.

You can protect your shotgun by following a basic rule: *After shooting, never leave your gun overnight without a thorough cleaning.* Generally, a simple solution of water and any conventional dishwashing soap along with a bottle of cleaning solvent are all you will need to clean the gun. Commercial black powder solvents are effective in removing residue. Lastly, the gun’s metal parts must be protected with a light layer of oil.

### Cleaning the Barrel

**Step 1—Flushing.** With a hooked-breech design, bring the hammer to full cock, remove the ramrod and barrel key, and slip the barrel from the stock. Using a mop or patch on your ramrod, saturate the bore and fouling with black powder solvent or with soap and water. Then insert the breech end of the barrel in a bucket of hot, soapy water. With a cleaning rod and attached mop of proper size, “pump” the water up through the bore, moving up and down the full length of the bore several times. Repeat this procedure using clean, hot water and pumping until the barrel is clean.

In cases where the breech, barrel, and *tang* are a single part, it’s not a good idea to try to separate the barrel. With a percussion gun, you can siphon soapy water from a bucket with a flush-out nipple: Remove the standard shooting nipple from your gun with the nipple wrench and replace it with a flush-out nipple, which is designed to fit securely in the nipple channel but has a large hole that can function as the entry point for water.

**A barrel key** is a flat iron or steel wedge used to secure a muzzleloader’s barrel to the stock.

Weight the free end of a length of plastic or rubber tubing (The kind used as the fuel line in model airplanes works well; it must be of a diameter to fit securely over the flush-out nipple.) and place it in the water bucket. Position the gun so water will flow freely throughout the bore. Use the pumping process described above to scrub and rinse thoroughly. Scrub the standard shooting nipple in the same solution using an old toothbrush and a pipe cleaner or similar instrument.

A flush-out nipple cannot be used with a flintlock shotgun. With a flintlock, you may use a pipe cleaner to clear out the *flash hole*, the *flash channel*, and the lower end of the barrel. A commercial black powder solvent may be used to cleanse the bore. But be careful! Some of these substances can damage the finish of your stock. Use caution as to where you apply them. Scrub up and down the bore with several patches well saturated in a commercial cleaner or soap and water. This may be followed by pouring water in the muzzle and pouring it back out by inverting the barrel to flush out the worst of the fouling. Then wipe the bore again to be sure all the fouling has been removed. If it hasn't, repeat the saturation and flushing process.

**Step 2—Drying.** Once the barrel has been thoroughly flushed or cleaned, dry the whole apparatus. You can use a dry wool shotgun mop or a series of cloth strips attached to your cleaning rod by a slotted cleaning tip. Pass this fabric through the length of the bore several times. This will dry the metallic surfaces and remove any remaining foreign particles. The job is finished when the fabric comes out both clean and dry.

### **Cleaning the Lock**

Locks are usually attached to the stock with one or two bolts. You'll have to remove the lock for cleaning.

First, set the hammer at half cock. Start unfastening the bolts by unscrewing a few turns. Tap the bolt heads lightly. This will loosen the lock plates from their mortise (their foundation on the stock). You may then proceed with unscrewing the bolts. Once they are removed, carefully lift the lock components off the stock. This usually can be done with simple finger pressure. If you run into trouble, insert a small diameter drift pin from the right-hand lock and tap lightly. This should loosen the left-hand lock to ease its removal. The right-hand lock should now come off easily.

An old toothbrush steamed with very hot water should be fine for removing any fouling and dirt from both sides of the lock. Be sure you cover both sides of the lock. Don't be afraid of hot water. The hotter the water, the faster the lock will dry. Thoroughly wipe dry the entire lock surface. Coat lightly with gun oil and replace.

### **Finishing Up**

Before the gun is reassembled, protect your stock surface by wiping thoroughly with a clean patch or cloth dampened either with water or stock cleaner. Dry thoroughly and follow up with a light application of stock oil or wax preservative.

Before putting all the parts back together, make sure that no moisture from cleaning fluids remains in any of the spaces between the barrel and the stock. If hidden portions are still damp when the gun is assembled, those sensitive places could rust.

Once your gun is cleaned and oiled, it's ready for storage. Remember to keep it in a cool, dry place. Humidity can cause rusting. The location of your storage area is a matter of personal choice, but many shooters prefer to keep their guns in a locked cabinet or similar secure place.



## Learning to Shoot

The material earlier in this pamphlet covers the methods of safety, firing the shot, and shooting at targets.

When dry-firing a muzzleloader, a little advance preparation is required. The repeated striking of the hammer on the nipple when no cap is covering it calls for protection.



**Using rubber washers will aid in protecting the shotgun's nipple during dry-firing.**

In a percussion gun, the nipples can be protected by fitting with a neoprene or rubber washer such as the one found on a water faucet. Put the washer over the nipple. This will cushion the blow of the hammer and absorb most of the force. If you find the hammer still strikes the nipple, add another washer.

In a flintlock, you can provide similar protection by replacing the flint with a similarly shaped piece of hardwood. This way, you can experience the fall of the hammer and the action of the frizzen without producing wear or tear on either.



# Conservation and Hunting

Wildlife biologists have long recognized two key factors in game management.

- **Wildlife cannot be stockpiled like coal or oil.** Any area of land, or *habitat*, can support only a certain number of wild animals. If a decision is made to have more game (wild animals for hunting) in a specific area and it is stocked with additional animals in excess of the biological *carrying capacity* of the habitat area, what will happen? In time, all animals in excess of the biological carrying capacity of the land will be eliminated by the natural factors of disease, starvation, emigration, or predation.

**A habitat** is the place where a plant or animal naturally or normally lives and grows.

**Carrying capacity** is the population of animals that an area will support without being damaged.

- **Wildlife species naturally overproduce each year.** That is, more young are produced than necessary to continue the species, and more are produced than the habitat area can support. The extra animals are lost to disease, starvation, emigration, or predation. This is nature's way of making sure that there are enough surviving animals each year for a breeding *population* and that the strongest strains survive for reproduction. For example, only 8 percent of young rabbits grow to breeding age.

These principles apply despite what people do with animals. If extra animals are put into an occupied habitat, more animals than normal will die. If a few extra animals are taken by hunters, the remaining stock will soon bring the population up to a normal

---

**A population** is all of the individuals of the same species that live in one place.

---

range. Wildlife management experts try to arrange hunting seasons and bag limits (limits on the number of animals taken) so that hunters will harvest only the surplus. The hunting regulations they set ensure that hunters do not take too many animals. It is far better that hunters should get the healthful outdoor recreation and the meat by harvesting the surplus than to lose those surplus animals to disease, starvation, and other natural causes.

Without effective natural *limiting factors*, natural reproduction will cause an animal population to grow too large, and the result is damage to the habitat. For example, an unmanaged population of grazing animals such as deer will grow until its food and water supply will no longer support its members. In such situations, the large numbers of animals severely damage the plants in their habitat by overgrazing or browsing and by trampling the plants. Plants exposed to this kind of grazing pressure will not return to their former level of *productivity* for many years. The loss of productivity is equally harmful to other wildlife species with similar food and survival needs.

**A limiting factor** is anything that limits the survival, reproduction, or number of animals in an area.

**Productivity** in plants is the power to bear or yield food abundantly.

When it becomes obvious that a population is too large, it is important to increase the harvest and get the herd down to its biological carrying capacity. Game managers will often extend the hunting season and/or increase the bag limit to thin out the population. By harvesting animals that would otherwise be lost to causes such as starvation and disease, the hunter becomes a responsible participant in natural biological processes.

The real problem for wildlife is what humankind has done, and is doing, to the habitats where these animals must live. People are replacing woods, fields, and marshes with subdivisions, shopping centers, superhighways, industrial complexes, and airports. These changes lead to the destruction or alteration of habitats and to a smaller number of game animals.

(For more about these ideas, see the *Environmental Science* and *Fish and Wildlife Management* merit badge pamphlets.)

## Hunting Regulations

Each state has its own hunting regulations. These are issued by the state fish and wildlife agency, conservation department, or similar organization that is responsible for the state's fish and wildlife management program. You can get a copy of the regulations by writing to the correct department at your state capital. Locally, sporting goods and hardware stores that sell hunting and fishing licenses and equipment usually can supply a copy of the regulations. Your merit badge counselor can help you with this, also.

There are many differences in the state game laws. Hunting in Kansas is unlike hunting in California or New York. Differences in geography, human population, and game species call for different game laws. Even within a state, there will be some differences in game laws. Certain areas or counties may have different laws because of local conditions.

All states have regulations regarding the use or carrying of guns when hunting. These laws are designed to protect those in the hunting neighborhood. Such regulations may prohibit carrying a loaded gun in a car, shooting from a car, or shooting near buildings or roads. Many states control the type and caliber of gun that can be used for certain kinds of hunting.

The states require hunters to carry a hunting license. This helps them control the game harvest, and the license fees provide money for habitat improvement and game management. To get a hunting license for the first time, all states require the hunter to satisfactorily complete the hunter safety course initially developed by the National Rifle Association and now administered by each state's hunter education program. These courses are taught by volunteer instructors. (Several states "grandfathered" people born before a specified date, and those hunters were not required to take a hunter safety course. In other states, people who were licensed hunters in the state before a specific date established by law or regulation were not required to take a hunter safety course.)

Even if your state does not require you to take such a course, it is certainly worth your time to take it before you start hunting. You will find it interesting and informative. And if you have earned the Shotgun Shooting merit badge, you will find it easy.

---

In hunting language, **big game** usually refers to such animals as deer, elk, moose, antelope, and bear. **Small game** includes animals such as rabbits and squirrels. **Upland game** includes quail, grouse, partridge, and ptarmigan. **Waterfowl** includes birds such as ducks, geese, and coot.

---

## Sportsmanship

Sportsmanship applies to all of shooting, whether recreational, competitive, or hunting. The true sportsman follows the Golden Rule: Treat others as you would like them to treat you.

- The sportsman knows and always follows the rules of safe gun handling at home, on the range, and in the field. He knows and strictly follows the laws regarding possession and use of firearms.
- The sportsman knows and follows the letter and spirit of the hunting regulations.



- The sportsman is considerate of the landowner whose property he may be using. He asks permission to hunt on the property. He does not litter the area with trash.
- The sportsman is careful of the target, both for safety and also to avoid senseless destruction. He does not shoot powerline insulators, pipeline valves, signs, or similar property. He confines his shots to proper targets.
- The sportsman is careful of the area beyond the target to ensure that bullets that miss the target or ricochet do not travel on to cause damage.
- The sportsman, when hunting in the field, gives fellow hunters a fair chance at game. The sportsman does not take unfair advantage of another shooter in any way.

The accomplishment of taking game during the hunt is only part of the experience. Enjoying the outdoors, seeing wildlife, and stalking game are also pleasurable parts of the hunt.



## Glossary

**action.** The group of moving parts that allow the shooter to load, fire, and unload a gun.

**ammunition.** The projectiles with their cases, primers, and propelling charges that are fired from guns; cartridges.

**autoloader.** A repeating firearm. After it is loaded and cocked manually by the shooter for the first shot, the firearm then automatically loads a new cartridge from the magazine into the firing chamber and cocks itself for the next shot. *See also* semiautomatic.

**barrel.** The smooth tube through which the projectile passes.

**bead.** A spherical or cylindrical attachment on top of a shotgun barrel near the muzzle that assists in mounting and pointing the shotgun. A second bead may be located near the middle of the barrel.

**bench rod.** A ramrod with a large handle, made of brass, stainless steel, or other unbreakable material. Using a bench rod when target shooting is more comfortable for the shooter.

**black powder.** Gunpowder that burns explosively.

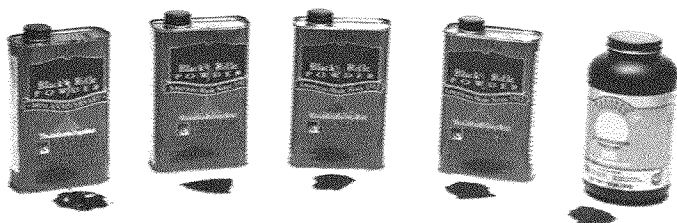

black powder

**bore.** The interior of a gun barrel.

**breech.** The rear position of a shotgun, usually the rear opening of the chamber into the barrel.



**breechblock.** A movable block of metal that closes the chamber at the rear and supports the base of the cartridge during firing.

**breechloader.** Any gun that is loaded from the breech, usually with a cartridge, as distinguished from a muzzleloader.

**breech plug.** A plug threaded into the breech of the barrel of a muzzleloading gun, to seal the breech against the rearward escape of gases when the gun is fired.

**butt.** The rear end of a gunstock.

**case.** The container, usually of plastic or paper with a brass head, that holds ammunition parts.

**chamber.** The rear portion of the gun barrel into which a cartridge is inserted for firing. "To chamber" is to insert a cartridge into the breech of a gun.

**charging the barrel.** Dispensing a specific amount of black powder directly into the muzzle of a firearm.

**choke.** A constriction near a shotgun muzzle that controls the spread of the fired shot charge.

**clay target.** A round, usually dome-shaped, easily breakable disk made of pitch that is thrown as a flying target for shotgun shooters. Also called "clay bird" and "clay pigeon."

**cock.** The hammer of a muzzleloader. "To cock" is to place the hammer of a firearm in the firing position.

**comb.** The upper edge of a stock. The shooter's cheekbone rests on the comb.

**drum.** A cylindrical piece of steel holding the nipple in a percussion gun.

**dry-firing.** Simulating shooting with an unloaded firearm, including cocking it and pulling the trigger; used to practice gun handling and control.

**firing line.** At a target range, the line along which shooters are positioned.

**firing pin.** The device that strikes that primer in the cartridge, igniting the primer by causing an indentation that crushes the priming compound.

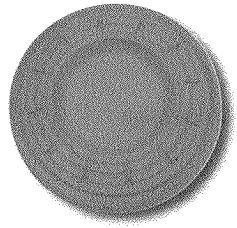

clay target

**flash channel.** A small hole between the inside of the barrel and the priming pan in a muzzleloading gun; *see* flash hole.

**flash hole.** A fire hole used in muzzleloaders; a small hole through the breech that runs from the ignition source to the powder charge.

**flint.** In a flintlock, the piece of stone that strikes the steel frizzen face to produce a shower of sparks, thus igniting the priming charge and, subsequently, the main charge in the barrel.

**flintlock.** A muzzleloader with a hammer, or cock, that holds a flint in screw-tightened jaws; having a frizzen, or striking plate; a pan in which the priming charge is placed; and a flash hole through which the flame passes to the main charge in the barrel.

**follow-through.** Maintaining gun mount and movement briefly after firing the shot.

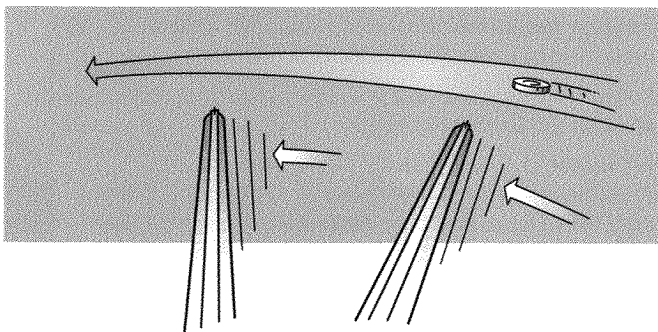

follow-through

**forearm.** *See* fore-end.

**fore-end.** That part of a gun's stock forward of the action, extending under the barrel and providing a grip for one hand below the barrel.

**frizzen.** In a flintlock, the spring-loaded cover of the priming pan, with an upright steel plate against which the flint strikes, producing the sparks that ignite the powder.

**frizzen face.** The striking surface of a frizzen.

**full cock.** The position of the cock or hammer when ready for firing. *See* half cock.

**gauge.** A measure of shotgun bore size equivalent to the number of lead balls of bore diameter required to weigh 1 pound.

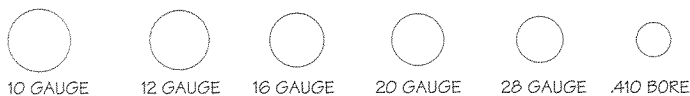

gauge

**grip.** The part of the stock gripped by the firing hand. Sometimes called the *small* of the stock.

**gunsmith.** A person who designs, makes, or repairs guns.

**half cock.** A hammer position at the midpoint of hammer travel; an intermediate safety position for the cock or hammer. See full cock.

**hammer.** The part that strikes the percussion cap in muzzleloaders or the primer in cartridge arms. Some hammers directly strike the cap or primer, while others strike a separate firing pin. The hammer on flintlocks is called the cock.

**hangfire.** A delay in the ignition of a cartridge at the time of firing, often described as the “click” of the firing pin being followed by a delay, then the “bang” of firing.

**hinge.** A type of shotgun action that opens like the movement of a door hinge; when the release lever is pushed to one side, the barrel swings downward.

**hooked breech.** A style of muzzleloading rifle in which the barrel can be removed from the standing breech.

**jag.** The end of a cleaning rod, having grooves or ridges that grip a cleaning patch or swabbing material.

**live firing.** Shooting with a loaded firearm, using live ammunition.

**load.** A particular combination of case, primer, powder, and shot. “To load” is to charge a firearm with ammunition.

**lock.** The firing mechanism of early firearms. See flintlock and matchlock.

**magazine.** In a repeating firearm, the container in which cartridges are stored before loading, one by one, into the chamber.

**match.** The fuse, wick, or smoldering cord used in matchlock firearms.

**matchlock.** A muzzleloader in which a lighted match is touched to the powder in the priming pan, igniting the priming charge, which in turn shoots its flame through the flash hole to set off the powder charge in the barrel.

**misfire.** The failure of a round to fire.

**muzzle.** The forward end (mouth) of the barrel, through which the shot exits.

**muzzle velocity.** The speed of the shot measured as it leaves the muzzle of the barrel.

**muzzleloader.** Any gun that must be loaded through the muzzle by charging first with black powder, followed by the lubed or patched projectile.



**nipple.** The cone-shaped seat on which a percussion cap is placed and detonated by the hammer of a muzzleloader. The nipple has a hole through it to let the flame from the cap travel to the powder charge in the barrel.

**pan.** On matchlock, wheel lock, and flintlock guns, a small, shallow container for priming powder.

**patch.** A piece of material, usually cotton, fitted around a round ball in a muzzleloading gun to provide a gas seal and to impart spin to the ball.

**pellet.** A single piece of shot.

**percussion cap.** A small metal cup containing a priming mixture (detonating powder), placed open-end-down over a nipple that has a vent hole leading into the main powder charge in the barrel of a percussion rifle. When struck by the hammer, the cap sends a small jet of flame into the powder charge, igniting it.

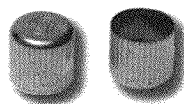

percussion cap

**possibles bag.** A pouch carried by a muzzleloader shooter, for packing necessary gear.

**powder charge.** A measured amount of a chemical compound that, when ignited by the primer, generates gases that expand rapidly and produce high pressure, providing the force needed to propel a projectile. In modern cartridges, the powder charge is contained within the case. In muzzleloading rifles, the powder charge is loaded into the barrel through the muzzle. The black powder used in muzzleloaders is quite different from the powder used in modern cartridges.

**powder horn** or **powder flask.** A container for holding black powder. Modern powder flasks are usually made of metal, with a spout on one end and a lever at the side that opens the flask to pour out a measured amount of powder.

**powder measure.** A device for measuring and dispensing precise quantities of powder.

**primer.** In cartridge arms, an impact-sensitive chemical mixture that ignites when hit by the firing pin, igniting the powder charge. Also, in centerfire ammunition, the metal cup or pocket that contains the primer.

**priming powder.** The fine-grained powder that is used in the pan of a flintlock and that, when set off, ignites the main charge of powder.

**projectile.** Any solid material propelled through the gun barrel by pressure—a bullet, ball, BB, pellet, etc.

**prone position.** A shooting position in which the shooter lies facing the target, body angled slightly, both elbows and almost all of the body in contact with the ground.

**pull.** The command spoken by a clay target shooter to request the target to be thrown.

**pump action.** A term applied to repeating firearms activated by a sliding action that is operated by moving a handgrip below the barrel backward and forward.

**Pyrodex®.** A black powder that burns without the heavy fouling of regular black powder.

**ramrod.** A rod used in loading and cleaning muzzle-loading guns.

**receiver.** The frame for the action parts of a gun, and the part of the firearm around which the rest of the arm is built. A firearm's stock is attached to the receiver; the barrel is screwed or locked into the receiver; and the receiver also accepts the bolt, magazine, trigger mechanism, etc.

**recoil.** The rearward movement of the gun in reaction to the forward movement of the projectile and powder gas emerging from the muzzle; the kickback of a gun upon firing.

**repeater.** *See* semiautomatic.

**rib.** A flat steel bar attached to the top of the length of a shotgun barrel.

**round.** Another name for a cartridge, or a series of a certain number of shots.

**safety.** A device that prevents a firearm from being accidentally fired, normally by blocking the trigger or the hammer action or by locking the bolt or lever.

**semiautomatic.** A firearm that fires the cartridge in the chamber, ejects the fired casing, and chambers a fresh round from the magazine with each pull of the trigger. *See also* autoloader.

**short-starter.** The short peg of a ball-starter, used to seat a patched ball or lubed bullet just below the muzzle of a muzzleloading gun.

**shot.** Small spheres of metal, usually lead or steel, used as projectiles in shotgun ammunition.

**shotshell.** A cartridge comprised of a case, primer, powder, wad, and shot designed to be fired in a shotgun.

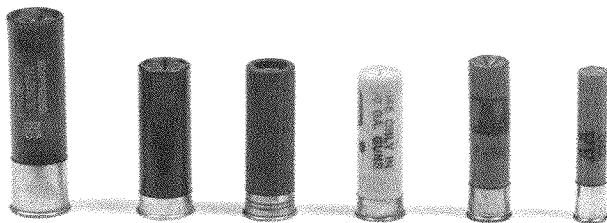

shotshell

**sight picture.** The visual relationship between the target and the gun's muzzle.

**slide action.** See pump action.

**squib load.** A round that fires but may not produce enough gas pressure to force the wad out of the barrel.

**stock.** The part of the rifle that the shooter grasps, usually made of wood, and consisting of the butt, comb, grip, and fore-end.

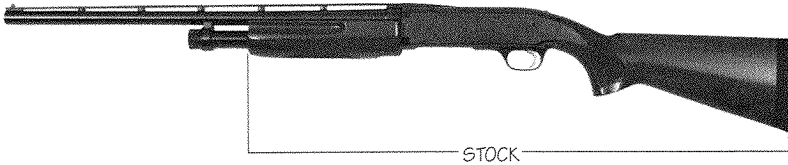

**tang.** The part of a firearm's receiver that extends to the rear and is used to attach the action to the stock.

**thimbles.** Short metal tubes used to secure the ramrod under the barrel of a muzzleloading gun.

**trigger.** The lever that causes a firearm to fire when moved, usually pulled by one finger.

**trigger guard.** A protective shield around the trigger that guards against accidental release of the trigger.

**trigger pull.** The amount of pressure needed to fully release a trigger to fire a gun.

**wad.** Cylindrical plastic or fiber component of a shotshell or muzzleloading shotgun load used to separate the powder charge from the shot and prevent combustion gases from bypassing the shot charge upon firing, or to retain the shot charge prior to firing.

**wrist.** The part of the stock between the butt and the fore-end that is gripped by the trigger-hand.

# Shotgun Shooting Resources

## Scouting Literature

*Environmental Science, Fish and Wildlife Management, and Rifle Shooting* merit badge pamphlets; *Guide to Safe Scouting*; *National Shooting Sports Manual* (Appendix 1).

Visit the Boy Scouts of America's official retail website (with your parent's permission) at <http://www.scoutstuff.org> for a complete listing of all merit badge pamphlets and other helpful Scouting materials and supplies.

## Books

Bridges, Toby. *Muzzleloading*. Creative Publishing, 1997.

Brister, Bob. *Shotgunning: The Art and the Science*. Winchester Press, 1977.

Galan, J. I. *Airgun Digest*. DBI Books, 1995.

Henderson, David R. *Gunsmithing Shotguns: A Basic Guide to Care and Repair*. Lyons Press, 2003.

Malloy, John. *Complete Guide to Guns and Shooting*. DBI Books, 1995.

McIntosh, Michael. *Shotguns and Shooting: A Celebration of the Gun*. Countrysport Press, 1995.

Meyer, Jerry. *The Clay Target Handbook*. Lyons Press, 1995.

Migdalski, Tom. *The Complete Book of Shotgunning Games*. McGraw-Hill, 1998.

Morrow, Tom. *The Orvis Field Guide to Shotgun Care and Maintenance*. Willow Creek Press, 2000.

Re, Lois. *Black's Wing and Clay: The Complete Shotgunner's Guide to Equipment, Instruction, and Destinations*. Masters Press, 1999.

Russell, James. *Precision Shooting: The Trapshooter's Bible for the Advanced Trapshooter and Those Who Strive to Be*. James Russell, 1998.

———. *Trapshooting Secrets*. James Russell, 1999.

## Organizations and Websites

### Alco Target Company

Toll-free telephone: 888-258-4814

Website: <http://www.alcotarget.com>

### Amateur Trapshooting Association

Telephone: 618-449-2224

Website: <http://www.shootata.com>



**American Target Company**

Toll-free telephone: 877-733-0433  
 Website:  
<http://www.americantargetcompany.com>

**Discover the Outdoors:  
 Shooting Sports**

Website: <http://www.dto.com/shooting>

**Log Cabin Shop**

Website: <http://www.logcabinshop.com>

**Michaels of Oregon**

Website:  
<http://www.michaels-oregon.com>

**National Rifle Association  
 of America**

Toll-free telephone: 800-672-3888  
 Website: <http://home.nra.org>

**National Shooting  
 Sports Foundation**

Telephone: 203-426-1320  
 Website: <http://www.nssf.org>

**National Skeet Shooting Association**

**National Sporting Clays Association**

Toll-free telephone: 800-877-5338  
 Website: <http://www.nssa-nasca.com>

**National Target Company**

Toll-free telephone: 800-827-7060  
 Website:  
<http://www.nationaltarget.com>

**Remington Arms Company**

Toll-free telephone: 800-243-9700  
 Website: <http://www.remington.com>

**Shotgun News Magazine**

Website: <http://www.shotgunnews.com>

**Shotgun Sports Magazine**

Telephone: 530-889-2220  
 Website:  
<http://www.shotgunsportsmagazine.com>

**Target Barn Inc.**

Telephone: 419-829-2242  
 Website: <http://www.targetbarn.com>

**The Target Shop**

Telephone: 856-358-5140  
 Website:  
<http://www.thetargetshop.com>

**Trapshooters.com**

Website: <http://www.trapshooters.com>

**U.S. Target Inc.**

Toll-free telephone: 800-746-6836  
 Website:  
<http://www.ustargetonline.com>

**USA Shooting**

Telephone: 719-866-4670  
 Website: <http://www.usashooting.com>

**Photo and Illustration Credits**

- ©Comstock Inc., 1999—cover  
*(clay targets, shotgun shells)*
- ©Jupiterimages.com—page 84
- ©Photos.com—cover *(top right, powder horn)*; pages 59–60, 80, and 85

All other photos and illustrations not mentioned above are the property of or are protected by the Boy Scouts of America.

John McDearmon—all illustrations on pages 12, 16–18, 20, 36, 40–41, 47, 50, 53, 61, and 88

## Acknowledgments

The Boy Scouts of America is grateful to the men and women serving on the Merit Badge Maintenance Task Force for the improvements made in updating this pamphlet.

## Thanks to the NRA

For their indispensable contributions to this edition of the *Shotgun Shooting* merit badge pamphlet, the Boy Scouts of America thanks Bill Poole, Charles H. Mitchell, and Don Sipes of the National Rifle Association of America. Thanks to J. Franklin Sturges Jr., National Camping School shooting sports director, Denver Area Council shooting sports coordinator, and NRA training counselor, for his assistance with this revision. We appreciate Troop 1995, Centreville, Virginia, of the BSA's National Capital Area Council, Bethesda, Maryland, for their assistance with the photographs used in this book.

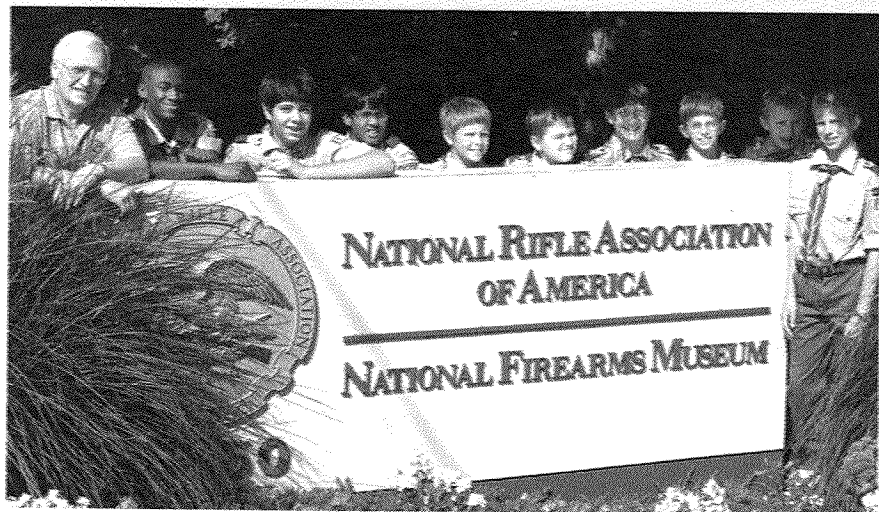

## MERIT BADGE LIBRARY

Though intended as an aid to Boy Scouts, Varsity Scouts, and qualified Venturers and Sea Scouts in meeting merit badge requirements, these pamphlets are of general interest and are made available by many schools and public libraries. The latest revision date of each pamphlet might not correspond with the copyright date shown below, because this list is corrected only once a year, in January. Any number of merit badge pamphlets may be revised throughout the year; others are simply reprinted until a revision becomes necessary.

If a Scout has already started working on a merit badge when a new edition for that pamphlet is introduced, *he may continue to use the same merit badge pamphlet to earn the badge and fulfill the requirements therein.* In other words, the Scout need not start over again with the new pamphlet and possibly revised requirements.

Merit Badge Pamphlet	Year	Merit Badge Pamphlet	Year	Merit Badge Pamphlet	Year
American Business	2002	Environmental Science	2006	Plant Science	2005
American Cultures	2005	Family Life	2005	Plumbing	2004
American Heritage	2005	Farm Mechanics	2008	Pottery	2008
American Labor	2006	Fingerprinting	2003	Public Health	2005
Animal Science	2006	Fire Safety	2004	Public Speaking	2013
Archaeology	2006	First Aid	2007	Pulp and Paper	2006
Archery	2004	Fish and Wildlife Management	2004	Radio	2008
Architecture and Landscape Architecture	2010	Fishing	2009	Railroading	2003
Art	2006	Fly-Fishing	2009	Reading	2003
Astronomy	2013	Forestry	2005	Reptile and Amphibian Study	2005
Athletics	2006	Gardening	2013	Rifle Shooting	2001
Automotive Maintenance	2012	Genealogy	2005	Robotics	2011
Aviation	2006	Geocaching	2010	Rowing	2006
Backpacking	2007	Geology	2005	Safety	2006
Basketry	2003	Golf	2002	Salesmanship	2003
Bird Study	2005	Graphic Arts	2006	Scholarship	2004
Bugling ( <i>see Music</i> )		Hiking	2007	Scouting Heritage	2010
Camping	2005	Home Repairs	2009	Scuba Diving	2009
Canoeing	2004	Horsemanship	2010	Sculpture	2007
Chemistry	2004	Indian Lore	2008	Search and Rescue	2012
Chess	2011	Insect Study	2008	Shotgun Shooting	2005
Cinematography	2008	Inventing	2010	Skating	2005
Citizenship in the Community	2005	Journalism	2006	Small-Boat Sailing	2004
Citizenship in the Nation	2005	Kayaking	2012	Snow Sports	2007
Citizenship in the World	2005	Landscape Architecture ( <i>see Architecture</i> )		Soil and Water Conservation	2004
Climbing	2011	Law	2003	Space Exploration	2004
Coin Collecting	2008	Leatherwork	2002	Sports	2006
Collections	2008	Lifesaving	2008	Stamp Collecting	2007
Communication	2009	Mammal Study	2003	Surveying	2004
Composite Materials	2006	Medicine	2009	Swimming	2008
Computers	2009	Metalwork	2007	Textile	2003
Cooking	2007	Model Design and Building	2010	Theater	2005
Crime Prevention	2005	Motorboating	2008	Traffic Safety	2006
Cycling	2003	Music and Bugling	2003	Truck Transportation	2005
Dentistry	2006	Nature	2003	Veterinary Medicine	2005
Disabilities Awareness	2005	Nuclear Science	2010	Water Sports	2007
Dog Care	2012	Oceanography	2009	Weather	2006
Drafting	2008	Orienteering	2003	Welding	2012
Electricity	2004	Painting	2008	Whitewater	2005
Electronics	2004	Personal Fitness	2006	Wilderness Survival	2007
Emergency Preparedness	2012	Personal Management	2003	Wood Carving	2006
Energy	2005	Pets	2003	Woodwork	2011
Engineering	2008	Photography	2013		
Entrepreneurship	2006	Pioneering	2006		

### BOY SCOUTS OF AMERICA • SUPPLY GROUP

#### NATIONAL DISTRIBUTION CENTER

2109 Westinghouse Boulevard  
P.O. Box 7143  
Charlotte, NC 28241-7143

[www.scoutstuff.org](http://www.scoutstuff.org)

#### DIRECT MAIL CENTER

P.O. Box 909  
Pineville, NC 28134-0909  
For fast credit card orders—  
VISA, MasterCard, American Express—  
call BSA operators toll-free  
1-800-323-0732

ON THE ROAD TO HIGH ADVENTURE

THE SUPPLY GROUP IS READY TO BE A PARTNER ON YOUR TRAIL TO EAGLE THROUGH HIGH ADVENTURE. THE ADVENTURE IS YOURS. AND WE ARE READY WITH THE GEAR YOU WILL NEED. YOU CAN DEPEND ON THE LATEST IN LIGHTWEIGHT, DURABLE, QUALITY GEAR THAT WILL MEET AND SURPASS YOUR TOUGHEST REQUIREMENTS.



WWW.SCOUTSTUFF.ORG

SKU 618655



35948 2013 Printing

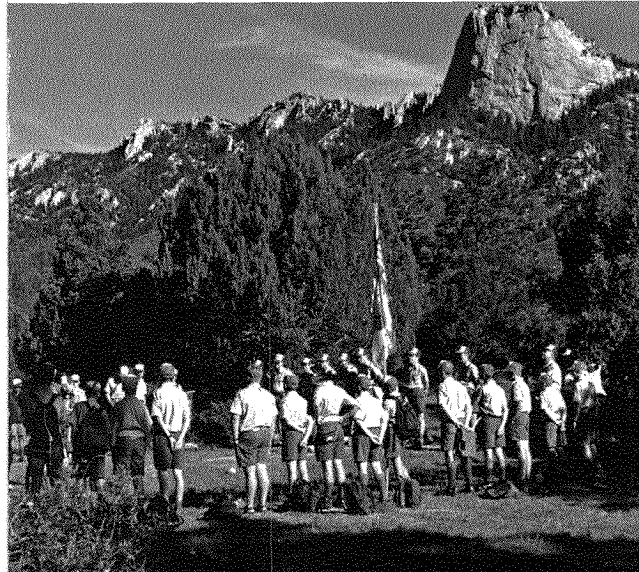

PHILMONT SCOUT RANÇH

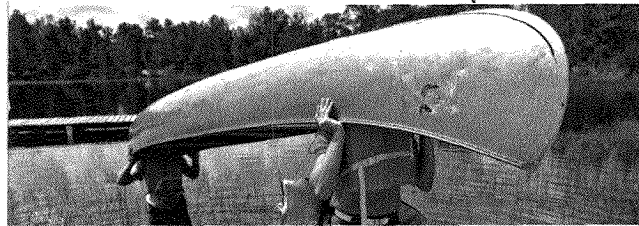

NORTHERN TIER

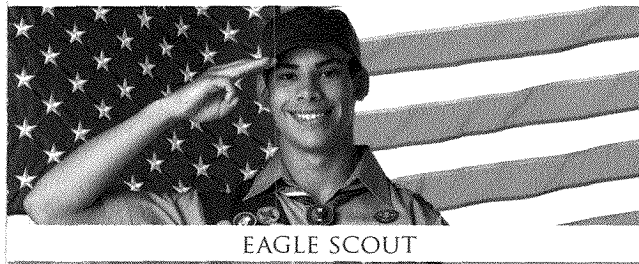

EAGLE SCOUT



FLORIDA SEA BASE