

MERIT BADGE SERIES

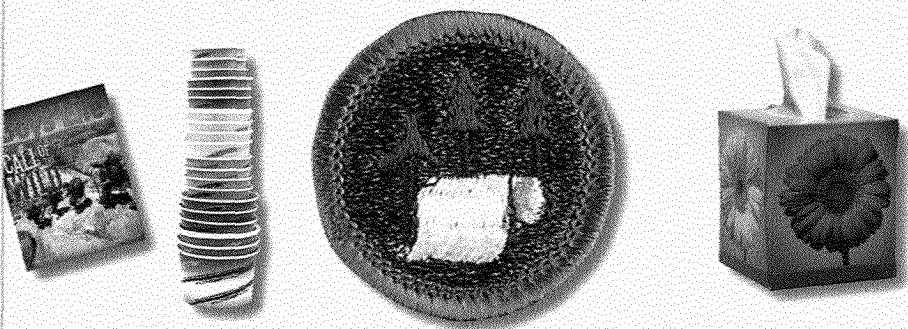

PULP AND PAPER



BOY SCOUTS OF AMERICA®

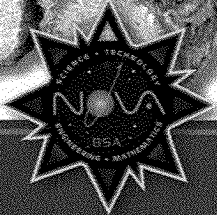

STEM-Based

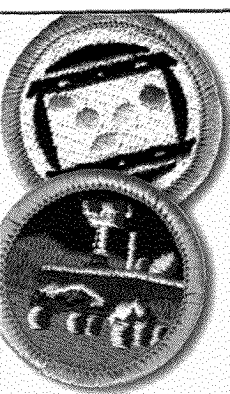

How to Use This Pamphlet

The secret to successfully earning a merit badge is for you to use both the pamphlet and the suggestions of your counselor.

Your counselor can be as important to you as a coach is to an athlete. Use all of the resources your counselor can make available to you. This may be the best chance you will have to learn about this particular subject. Make it count.

If you or your counselor feels that any information in this pamphlet is incorrect, please let us know. Please state your source of information.

Merit badge pamphlets are reprinted annually and requirements updated regularly. Your suggestions for improvement are welcome.

Who Pays for This Pamphlet?

This merit badge pamphlet is one in a series of more than 100 covering all kinds of hobby and career subjects. It is made available for you to buy as a service of the national and local councils, Boy Scouts of America. The costs of the development, writing, and editing of the merit badge pamphlets are paid for by the Boy Scouts of America in order to bring you the best book at a reasonable price.

Send comments along with a brief statement about yourself to
Pilots and Program Development, S272

Boy Scouts of America • 1325 West Walnut Hill Lane • Irving, TX 75038
If you prefer, you may send your comments to merit.badge@Scouting.org.

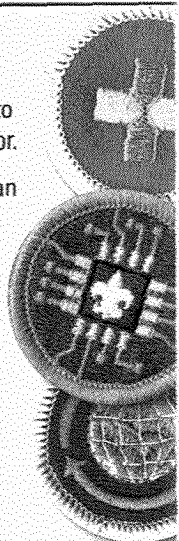

BOY SCOUTS OF AMERICA
MERIT BADGE SERIES

PULP AND PAPER

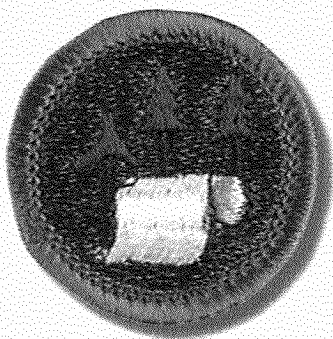

"Enhancing our youths' competitive edge through merit badges"



BOY SCOUTS OF AMERICA®

Requirements

1. Tell the history of papermaking. Describe the part paper products play in our society and economy.
2. Learn about the pulp and paper industry.
 - a. Describe the ways the industry plants, grows, and harvests trees.
 - b. Explain how the industry manages its forests so that the supply of trees keeps pace with the demand.
 - c. Tell how the industry has incorporated the concepts of sustainable forest management (SFM).
 - d. Describe two ways the papermaking industry has addressed pollution.
3. Name at least four types of trees that are major sources of papermaking fibers. Then do the following:
 - a. Discuss what other uses are made of the trees and the forestland owned by the pulp and paper industry.
 - b. Describe two ways of getting fibers from wood, and explain the major differences between them.
 - c. Tell why some pulps are bleached, and describe the process.

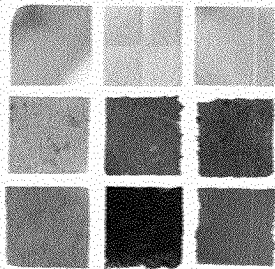

4. Describe how paper is made. Discuss how paper is recycled. Make a sheet of paper by hand.
5. Explain what coated paper is and why it is coated. Describe the major uses for different kinds of coated papers. Describe one other way that paper is changed by chemical or mechanical means to make new uses possible.
6. Make a list of 15 pulp or paper products found in your home. Share examples of 10 such products with your counselor.
7. With your parent's and counselor's approval, do ONE of the following:
 - a. Visit a pulp mill. Describe how the mill converts wood to cellulose fibers.
 - b. Visit a paper mill and get a sample of the paper made there. Describe the processes used for making this paper. Tell how it will be used.
 - c. Visit a container plant or box plant. Describe how the plant's products are made.
 - d. Visit a recycled paper collection or sorting facility. Describe the operations there.
 - e. Using books, magazines, your local library, the internet (with your parent's permission), and any other suitable research tool, find out how paper products are developed. Find out what role research and development play in the papermaking industry. Share what you learn with your counselor.
8. Find out about three career opportunities in the papermaking industry that interest you. Pick one and find out the education, training, and experience required for this profession. Discuss this with your counselor, and explain why this profession might interest you.

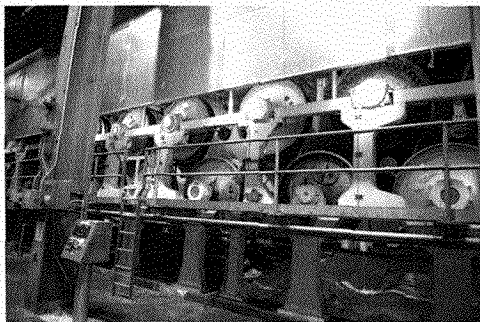



Contents

A Brief History of Paper	6
A Walk Through the Papermaker's Woods	13
How Paper Is Made	19
How We Use Paper Today	30
Making Paper by Hand	36
Careers in Pulp and Paper	43
Papermaking Resources	46



A Brief History of Paper

Nearly 2,000 years ago, in the year 105, a Chinese man named Ts'ai Lun ground up some plants, including mulberry bark and hemp. He may also have recycled old rags into the mixture. He

added water and mixed up the fibers until he had a big, squishy mess. Then he spread the wet pulp on a cloth screen framed in bamboo. He set the thin mat of fibers in the sun to dry.

Some archaeological evidence suggests there may have been other papermakers even earlier than Ts'ai Lun, but he was the first to have his work recorded for history.

The Chinese kept papermaking their secret for hundreds of years, but gradually their Korean and Japanese neighbors learned the art. Then, in 751, the Chinese lost a battle with the Arabs in Central Asia. The victorious Arabs made prisoners of several Chinese papermakers and took them to Samarkand, an ancient city that today is in Uzbekistan. From the captured Chinese papermakers, the Arabs learned the art of papermaking.

Paper spread across the Arab world, from the Middle East to Egypt (where it displaced papyrus)



Papermaking began in China in about A.D. 105. The bark of the mulberry tree (pictured top right) was shredded, mixed with scraps of linen and hemp, soaked, and beaten into a pulp. The pulp was dipped up on a mold (bottom left), and the water drained away to form a sheet of paper (bottom right). The Chinese symbol for paper is shown at top left.

Ts'ai Lun was a court official and a scholar. What he invented that day would change the world. He made paper, one of the most important inventions of all time. Imagine getting through just one day without a product made from paper.

and westward to Morocco. The Moors from North Africa brought papermaking to Europe. These Arabic invaders, after conquering Spain, built Europe's first paper mill there in about 1150. Then Italy became a major paper producer in 1250.

Soon the art spread to France, where monks in the 1300s began making paper for holy texts. European monks had long used parchment, made from animal skins that were stretched, scraped, dried, and cut to the right size. Parchment was extremely expensive. It has been estimated that a single Bible handwritten on parchment required the skins of 300 sheep.

When Johannes Gutenberg of Germany perfected the movable-type printing press in the 1450s, a tremendous thing happened. Books suddenly became available to ordinary people. Before Gutenberg, books had been so rare and costly that only monasteries, royalty, and scholars could own them. Now, even poor people could get their hands on books.

People became better educated. More people learned to read, they wanted more books, and the demand for paper skyrocketed. Papermakers couldn't find enough old clothes and rags to turn into enough paper to meet the demand. Surely, they thought, there had to be something they could use that would provide plentiful papermaking material so books and writing paper could be made widely available at low cost.

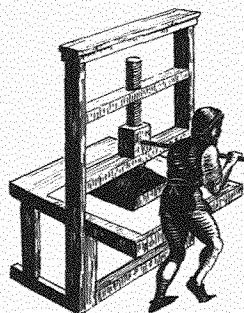

B.P. (Before Paper)

You have to go back a lot longer than 2,000 years to discover when people started writing. It seems from the time of the cavemen, people wrote and painted on cave walls. Early on, they drew designs on wood, on wet clay, and on metal. The Chinese, before Ts'ai Lun gave them paper, wrote on silk cloth—very expensive stuff—and made heavy, clumsy books from bamboo. The ancient Greeks used parchment made from animal skins. Egyptians more than 5,000 years ago wrote on papyrus made from Nile River reeds, cut into thin strips and crisscrossed in layers, then hammered together into thin, hard sheets. Our word “paper” comes from the word *papyrus*, but papyrus was not true paper as we know it today.

Early paper was made from cotton and linen rags. Papermakers had a tough time getting enough rags. When the Black Death, a horrible plague, killed millions of people in Europe during the 1300s, tons of rags from clothing became available for use, and dealing in old rags became a thriving trade. Some historians say the Black Death entered England from Europe on these infected rags.

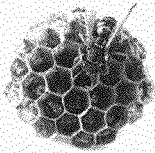

In the 1700s, a French scientist named René Antoine Ferchault de Réaumur realized what could be used as a plentiful papermaking material. Réaumur watched a paper wasp build a nest out of chewed-up wood. The wasp would chew on wood, grind it up, digest it with its internal enzymes (an early form of what we call biopulping today), and spit it out, making a fine paper to create its nest bit by bit. As far as we know, Réaumur never tried to chew up wood himself to make paper with it. However, he found that paper could be made from wood, and wood was plentiful and practical. A major step toward modern papermaking had been taken, but it would not be until the late 1800s that technology was developed to use wood on a large scale in papermaking.

Papermaking in Colonial America

The first paper mill in America was built in 1690 near Germantown, Pennsylvania, by William Rittenhouse. He had been an apprentice papermaker in Holland. He settled near Philadelphia because the city's population was big enough to provide him with the main raw material that was still being used for paper at that time: old rags. He also chose a spot where there was plenty of water, the other necessary ingredient for making paper. The first American papermakers were trained at the Germantown mill—one sheet at a time.

Making paper by hand, sheet by sheet, was slow and tedious. The rags were washed and then kept damp for weeks so they would partly rot. The wet, decaying rags were then ground into a pulp and pounded with water in large wooden vats to make a creamy batter.

Then it was the role of a skilled “vatman” to dip up a thin layer of the pulp on a wire screen stretched over a wooden frame. This equipment was called a mold. The vatman drained off the excess water, then gave the mold several sharp jerks to shake out most of the remaining water and to help mat and lock the fibers together for strength.

No Squares Here

Why is paper rectangular in shape, not square? Probably because early papermakers—vatmen—found it easier to control rectangular molds than square ones. The rectangular shape made it easier to dip the mold into the vat, then jerk the layer of pulp evenly. Tradition kept the shape rectangular, even after papermaking machines took over from skilled vatmen.

The vatman passed the mold to the “coucher,” who carefully turned the mold over on top of a piece of felt and gently pressed on the wire screen until the wet paper fell out of the mold. The coucher stacked a layer of felt between each sheet of wet paper until the stack grew to 144 papers. Then the stack, or post, was squeezed in a press to force out water and compact the paper fibers together.

The post was turned over to a “layman” who carefully peeled the paper from the felt, then laid each sheet of damp paper on a fresh, dry piece of felt. The layman restacked all the sheets of paper, layering them as before with dry felt. Then the stack (the post) was again squeezed in the press to remove more water. This was repeated three times. After the last pressing, the paper was hung up to dry.

At this stage, the paper was too absorbent to print on. Ink would make blotches, like trying to write on a paper towel with a felt-tipped pen. To prepare the surface to take ink crisply, each dried sheet of paper was dipped in a vat of sizing, a gummy liquid. Then the sheets were once more layered with felt and squeezed in the press to remove the excess sizing and bond the sizing with the paper.

Because the process was slow and rags were hard to get, paper was always in short supply. In the early 1700s a good papermaking team could make only about 1,500 sheets of paper, about 22 by 30 inches, in one day’s work.

Still, with some paper available, the American colonists could publish newspapers. The first newspapers in the colonies were the *Boston News Letter* (founded in 1705), the *Boston Gazette* (1719), and *Bradford’s Mercury* (1719).

After a while, Great Britain required the colonists to pay a tax on newspapers and pamphlets. This new tax, imposed by the Stamp Act of 1765, did not sit well with the Americans.

One of the oldest words in papermaking is "ream." The word can be traced to the Arabic "rismah" or "rizmah," meaning a bale or bundle (of clothes, paper, etc.). In French the word is "rame," and the Dutch variation is "riem." Over time, the number of sheets of paper in a "bundle" or ream became fixed at about 480 or 500. In the United States, a 500-sheet ream of paper is the most common.

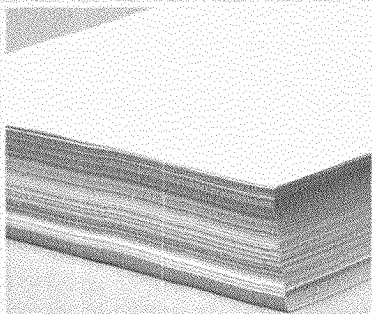

Colonial printers published works that spoke out against British rule, and the British government responded by trying to restrict papermaking in America.

So important was papermaking in the colonies that a skilled maker of paper molds, Nathan Sellers of Pennsylvania, was discharged from the American army in 1776 by a special resolution of the Continental Congress. They sent him home to make the molds that were desperately needed to produce paper for writing military orders and dispatches during the Revolutionary War.

The modern paper machines on which most of our paper is made today are basically just improved Fourdrinier machines.

From Handmade to Machine-Made Paper

In Europe, inventors continued to work on ways to speed up papermaking. In 1798, Nicholas-Louis Robert of France invented a machine that would form a continuous sheet of paper on a moving wire screen, making paper production much faster and less expensive than molding single sheets by hand. The invention, a huge step forward, was patented in 1799.

Two English brothers, Henry and Sealy Fourdrinier, developed a practical version of the continuous paper machine in the early 1800s. Mills in Britain, Europe, India, and America acquired these Fourdrinier machines, as they were commonly called. The first paper machine in the United States was set up in a mill near Philadelphia in 1817.

By 1810, the new United States boasted 185 paper mills. Rags for making paper became critically scarce, and the search was on for plentiful raw materials that could serve as a better alternative. Mills tested tree bark, sugarcane waste, straw, and cornstalks for sources of fiber.

Of the available raw materials, wood stood out as the best and most plentiful. Inventors developed workable ways to grind wood for making wood pulp. In the 1850s and '60s, English and American chemists found they could use chemicals to separate the wood fibers. About 1880, German chemist Carl F. Dahl perfected the use of wood for papermaking by adding yet another chemical. His sulfate, or kraft, method spread quickly and reached the United States in the early 1900s. (*Kraft* means "strength" in German.) Low-cost, mass-produced paper soon became available. Books, newspapers, and magazines were printed in large numbers. Schoolchildren gave up their writing slates in favor of paper.

Paper Firsts

Today, paper products such as cups, towels, and tissues are so common that we use them daily and hardly think about them. Not so long ago, however, people did not have these handy items. Consider these:

- Toilet paper, invented by American Joseph Gayetty in 1857, was considered a luxury item at first, but it came into widespread use after the Civil War.
- George Eastman manufactured coated photographic paper in 1885.
- In the 1800s it was common for people to drink after one another from a single cup attached to a public water fountain. Disposable paper cups came along in the early 1900s as protection against the germs and diseases that were spread by people drinking out of the same cup.
- During a cold epidemic in 1907, a Philadelphia teacher suspected that her students were spreading germs by all using the same cloth towel. She cut heavy paper into squares—the first paper towels—and gave them to her students to use.
- When cars came on the American scene, women began using more cosmetics to protect their skin from the effects of wind hitting their faces as they rode in cars that were open to the elements. Women used cold cream to remove the cosmetics, and they needed cloths for wiping away the cold cream. In the 1920s, facial tissues were developed for women to use for removing cold cream and makeup.

In 1863, the *Boston Weekly Journal* became the first American newspaper to be printed on paper made from ground wood pulp.

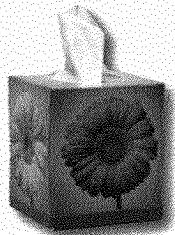
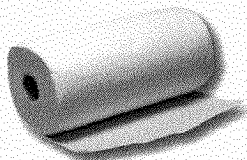
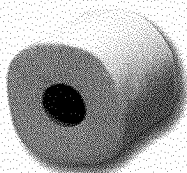



A Walk Through the Papermaker's Woods

Paper consists mainly of *cellulose*, a substance that strengthens the stems, roots, and leaves of trees, grasses, and other plants. Early papermakers discovered that the inner bark of certain shrubs and trees contains a fairly pure form of cellulose fibers. Wood is about half cellulose. The purest form of cellulose fibers that occurs naturally is cotton, which is more than 95 percent cellulose. The highest quality papers are almost pure cellulose.

Anselm Payen, a French chemist, identified cellulose in wood in the 1830s. Wood has been the major raw material in papermaking for more than 100 years because it is widely available and it is a *renewable* (replaceable) resource.

All fruits and vegetables contain cellulose. The stiff stalks of celery, for example, are rich in cellulose.

Many of the natural resources we use, such as ores, oil, and coal, are not renewable. Once they're taken from the ground, they can't be replaced. They are gone forever. Trees, however, are a renewable resource. We can plant and grow more of them to replace the ones we use.

Trees Used in the Paper Industry

Trees are often grouped as softwoods (needleleaf or evergreen trees) and hardwoods (broad-leaved trees that lose their leaves in the fall and winter). The wood fibers from different trees vary in length, from about $\frac{1}{32}$ to $\frac{1}{4}$ inch (1 to 5 millimeters) long. The longer fibers come from softwood trees such as pines, firs, hemlocks, and spruces. Broad-leaved trees such as aspens, beeches, birches, gums, maples, and oaks have short fibers.

The shorter hardwood fibers that provide bulk and smoothness in papers for printing and writing are used for softness in toilet tissue. The longer softwood fibers are used for papers that need to be strong, such as packaging papers. Papermakers mix these fibers in combinations, depending on what they want the finished paper to look like and how it will be used.

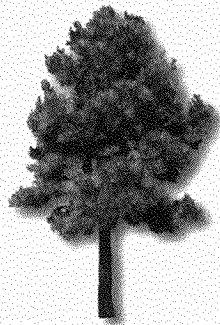

Pine—a softwood



**Spruce—
a softwood**

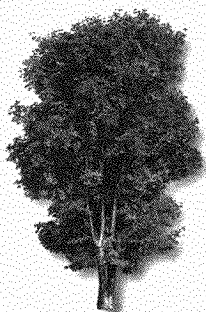

**Maple—
a hardwood**



**Oak—
a hardwood**

Some trees are grown and harvested, like a crop, especially for papermaking. Paper manufacturing uses leftover scraps of lumber and the trimmings, shavings, and wood chips from trees that are used for other purposes such as furniture making and building construction. In the United States, recycled paper and leftover wood make up about two-thirds of all the fiber used in pulp and paper mills. The other one-third comes from whole tree trunks. These whole trees are generally small, between 4 and 8 inches across. High-quality trees larger than 8 inches in diameter can be too valuable to chip up for paper. They're normally sawed into lumber—boards and planks.

Trees that are dying from old age, insects, disease, or forest fires are also used in papermaking. Foresters must remove these trees to keep the forest healthy, and it's sensible to use them for wood pulp.

Leaves, needles, small branches, and roots left in the forest enrich the soil and hold it in place, and can be used as biomass fuel to generate energy. Nearly every part of a tree gets used for something—lumber and paper, or for products ranging from photographic film to chewing gum, shoe polish, dyes, soaps, glues, medicines, rayon tire cord, and LCD screens in your TV and cell phones.

Sustainable Forestry

Many pulp and paper companies plant, harvest, and replant their own forestlands. In the United States, most of the trees that are harvested for papermaking are planted and grown in forests called *tree farms*. When these trees mature and are cut down, new ones are planted to replace them, a practice known as reforestation. This type of forest management is called *sustainable forestry*.

Professional forest managers know they must use forests wisely so that the trees and other resources are not permanently damaged or used up. Healthy, productive forests provide wood fiber for the products that the pulp and paper industries make. It's in these industries' best interests, therefore, to protect the health of forests at the same



time they harvest trees to make their products. Paper companies work to manage their lands so that the forests will keep on producing fiber for paper products, habitat for fish and wildlife, clean water, clean air, and woods where Scouts can go hiking and camping.

In the 1920s, people were predicting that demand for lumber, paper, and other wood products would use up the country's supply of trees by 1945. Not only have those predictions proved untrue, but today the United States has more trees than it did 90 years ago.

To sustain a thing means to keep it up or keep it going.



Forest Management Systems

Several methods, or systems, are used to harvest, then replant trees. Here's a quick look at the systems commonly used in American forests. (You can find more about these in the *Forestry* merit badge pamphlet.)

- **Clear-cutting** is harvesting all (or almost all) of the trees in an area of the forest. The cleared area is then sown with seeds or planted with seedlings. Or a new stand of trees, all the same age, may grow naturally from seeds dropped by trees around the cleared space, from seeds already on the forest floor, or from sprouts that grow from the stumps and roots of the cut trees. Clear-cutting is a common harvest method for trees grown for pulpwood.

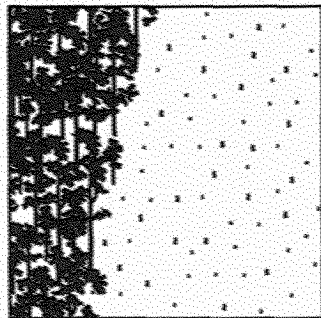

Clear-cutting

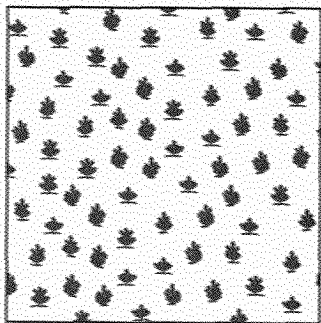

Seed trees

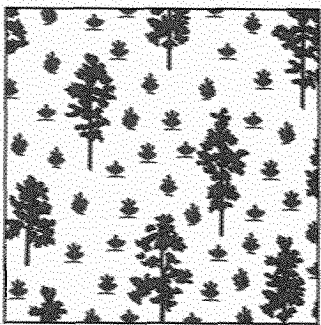

Shelterwood

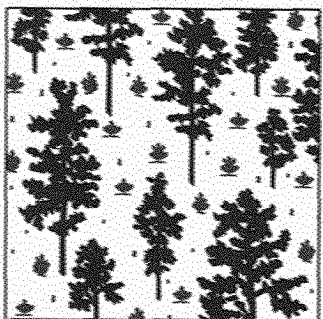

Single-tree selection

- **Seed trees** provide a natural source of seeds from which a new stand of trees grows after a mature stand is harvested. During harvesting, a few healthy seed-producing trees are left standing to reseed the area. Then, when the fresh crop of young trees has become established, the seed trees themselves are harvested. The seed-tree system can be used with various pines.
- In the **shelterwood system**, trees are harvested in stages over a period of 10 to 20 years. A new stand grows where an old one stood. The mature trees that are left uncut—the shelterwood—shade the seedlings and young trees. Such trees as oak, ponderosa pine, and white pine need shade when they're young. As the new trees grow up, the shelterwood trees can be harvested.
- In the **single-tree selection system**, trees are harvested individually as they mature. Seedlings or sprouts grow in the open spaces created. Similarly, small patches of mature trees can be selectively harvested, making room for younger trees but leaving many larger trees standing to produce seeds. Selection cutting creates only small openings in a forest, and so it works best with trees that grow well in shade, such as American beech and hemlock.
- **Improvement cuttings** may be made to thin the forest and remove undesirable trees—undersized trees or ones that are crowding larger trees, for example. **Salvage cuttings** are made to harvest trees damaged by wind, ice, or fire and to clear the way for new growth. **Sanitation cuttings** remove trees infested by insects or infected by disease, to protect the health of neighboring trees.

Forests and the Greenhouse Effect

You've probably heard of the *greenhouse effect*—the warming that happens when carbon dioxide and other gases trap heat in Earth's atmosphere much as a glass greenhouse captures sunlight. Many scientists believe the trapped heat can raise Earth's average temperature, cause sea levels to rise, and change the world's climate in ways that may lead to extreme, damaging weather.

Forests combat the greenhouse effect because, in wood, they naturally capture and store carbon (carbon dioxide) from the atmosphere. Products from the forest also store carbon. Paper and wooden houses and structures may store carbon for decades or throughout their lifetimes.

In this way, the cycling of carbon back into the atmosphere is delayed. The forests, especially young, vigorously growing forests like those used in the paper industry, are carbon *sinks*, good at "fixing" atmospheric carbon as trees take in far more carbon than they give out.

Recycling a ton of paper spares 17 trees, which can absorb up to 250 pounds of carbon dioxide from the air each year. If that same ton of paper were burned instead of recycled, it would create 1,500 pounds of carbon dioxide, which in turn would contribute to pollution and greenhouse gases.





How Paper Is Made

To see how wood is made into paper, let's start with a tree that is harvested from a tree farm. The tree's limbs are taken off, and the trunk is hauled to a pulp mill. At the mill, the bark is removed, to be burned for fuel or made into garden mulch. Then the wood in the trunk has to be separated into individual fibers, a process called *pulping*. And from the pulp, paper is made. These are the steps; illustrations showing this process appear on the next pages.

PULPING

Step 1—Separate the wood fibers, either by breaking them apart mechanically or by cooking the wood in chemicals until it falls apart, or by combining these methods to turn wood into pulp.

Step 2—Clean the pulp (step not shown).

Step 3—Bleach the pulp, if desired.

PAPERMAKING

Step 4—Rough up the fibers to create more surfaces for better fiber-to-fiber bonding. This process, called refining, makes for a stronger finished paper.

Step 5—Add dyes and fillers to the pulp to color the paper and give it other desirable properties (step not shown).

Step 6—Make the paper by spreading the watery pulp on a fast-moving forming fabric and draining off the water. Then press the wet paper to remove more water, and dry it on hot, steam-heated drying cylinders.

Step 7—Coat the paper, if desired.

Step 8—Form a jumbo roll, then rewind and slit the jumbo roll into shorter-width shipping rolls on paper cores.

CONVERTING

Step 9—Converting means cutting and shaping the paper to make boxes, cups, plates, bags, and many other products.

From log of wood to finished paper product, that's just nine steps. It can't be that easy, you say? Well, it is—and it isn't. Take a closer look at each step, and you will see how much science, technology, engineering, and mathematics go into making the paper you use every day.

Chemical Pulping for Papermaking—From Trees to Paper

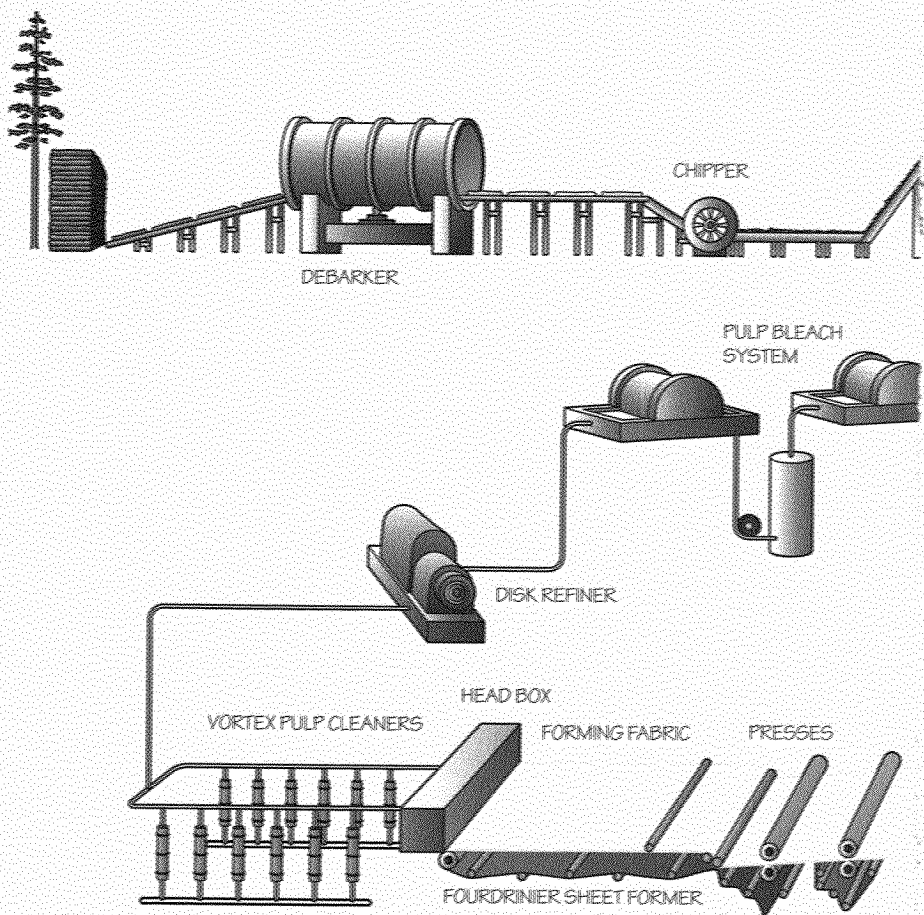

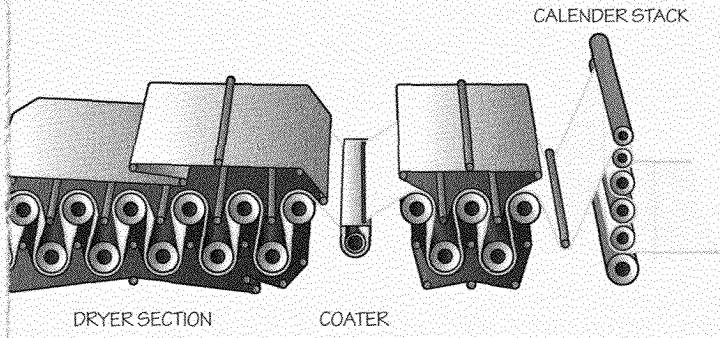
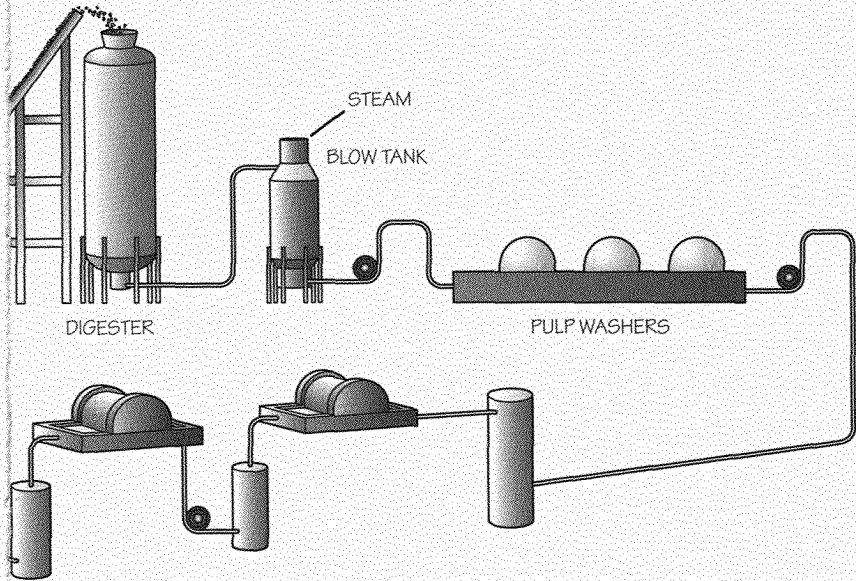

Pulp that is not made into paper in the same location as the pulp can be rolled, dried, and cut into sheets that are baled for shipment to papermaking facilities around the world.

Pulping

The three main pulping methods are mechanical, chemical, and semichemical (which combines chemical and mechanical methods).

Mechanical Pulping

Groundwood pulp. The original way that paper-makers made wood pulp was by mechanical means, simply grinding up the wood to separate the fibers. In the oldest mechanical method, called the *stone groundwood* process, short logs are pressed sideways against a grindstone that tears fibers out of the logs. Friction heats the wood and softens the *lignin* (a natural glue in trees that sticks the fibers together). The lignin is not removed. Paper made from groundwood pulp is good for printing on, but it's weak and—because of the lignin—it will discolor, especially in sunlight. Mechanical pulps are suited for low-quality printing papers that are used briefly, such as newsprint for newspapers.

Thermomechanical pulp (TMP). Though the old stone groundwood method hasn't altogether disappeared, modern methods of mechanical pulping have nearly replaced it. In the method known as *thermomechanical* pulping, the wood is first cut into chips about the size of a quarter. The chips are steamed to heat and moisten them, then fed through a machine called a refiner, which spins the chips at an elevated temperature and pressure. The disks tear the chips into fibers. This pulp makes a stronger paper than groundwood pulp, but its uses are similar.

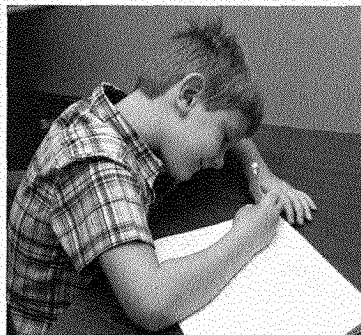

When you were younger and just learning to write, you may have used a grayish paper with wide rules. Get a piece of that kindergarten writing paper and hold it up to the light. Can you see bits of wood in it? This is an example of paper made from mechanical pulp. Such paper doesn't need to be strong, bright, or pure, because it isn't meant to last as long as a book printed on fine paper will last.

Logs to Chips. Logs are tumbled through a big, rotating debarking drum that removes the bark. Then the logs are cut into even-sized chips (about the size of quarters).

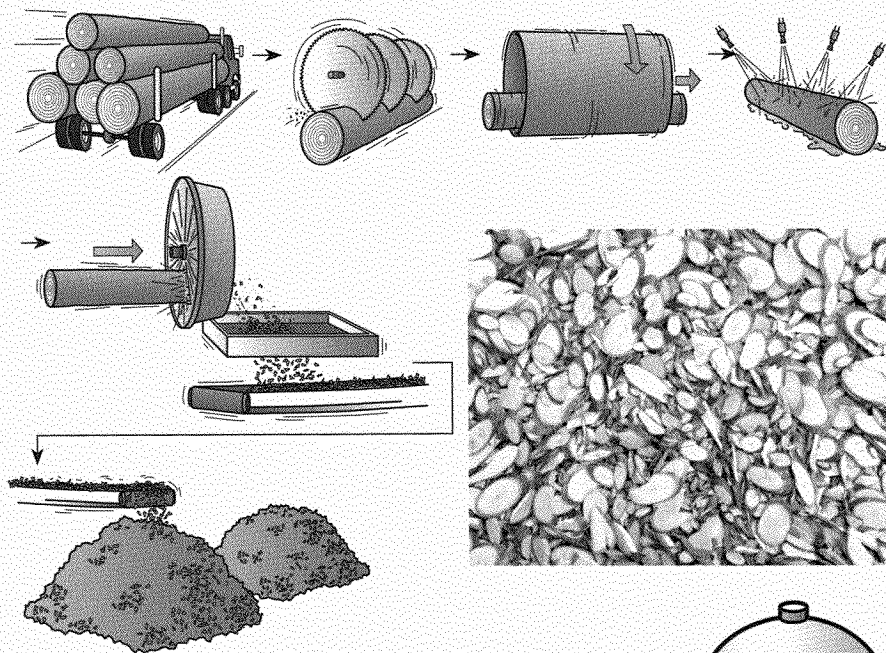

Chemical Pulping

In chemical pulping, chemicals dissolve and remove much of the lignin. Wood chips are cooked in a solution of water and chemicals, in a big pressure cooker called a digester, until the fibers fall apart. Chemical pulp produces strong paper that is used for printing and writing, shipping boxes, paper bags, and other products needing strength.

Chips to Fiber: The Digester. The wood chips go into the digester for cooking. The cooking chemicals dissolve the wood's lignin, the natural glue that holds wood fibers together. The used solution of chemicals is recovered to be recycled. The dissolved lignin is either burned to generate steam and electricity that is used in the mill, or is made into many different byproducts.

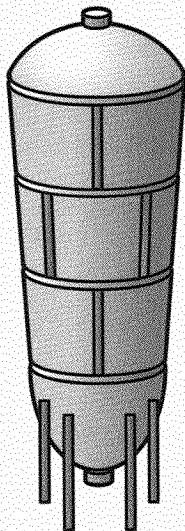

Finished pulp looks like watery mush. But examine a sample of pulp under a microscope, and you'll see the separate, individual wood fibers.

Semichemical Pulping

Semichemical processes also use chemicals to soften and break down lignin. But then special rotating disks are used to mechanically separate the wood fibers.

Cleaning and Bleaching

Pulps are screened to remove knots and clumps, and are washed to get rid of impurities and cooking chemicals, which are recycled. Some pulps are bleached to produce white paper. Good-quality writing papers are made from blends of bleached chemical pulps. Bleaching is often done in a series of steps, using different chemicals at each stage. The bleaching chemicals either remove the color-causing compounds from the pulp or make them colorless.

Brown to White: Bleaching. A series of chemical bleaching and washing processes turns brown wood fiber into white pulp. Unbleached pulp makes brown paper, as for grocery bags, kraft wrapping paper, and cardboard boxes.

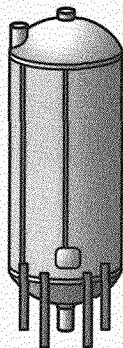

Rag Pulping

The oldest pulping process—rag pulping—is still done. New rags—scraps from the textile industry—are preferred, though old rags can be used. The rags are cut up, cooked in chemicals, then washed, bleached, and rewashed. The resulting pulp is used for making fine writing papers, business letterhead and art papers, and durable, high-quality papers for such things as blueprints, legal documents, and paper money.

The paper used for American paper money is a blend of cotton and flax. The long cellulose fibers in cotton and flax make a strong paper—which is why a dollar bill can go through the laundry, hidden in a pocket, without falling apart.



Papermaking

Here is how paper is made.

Refining

Most pulp can't be used for papermaking as it comes from the pulp mill. For most grades of paper, fibers direct from a pulping operation won't bond well enough to make a strong sheet. The fibers must be unraveled or frayed to increase their ability to bond. So before the fibers are put into a paper machine, various types of beaters and refiners are used to loosen them and make them more flexible so the fibers can bond together better. The quality of the paper depends on how much the pulp is refined.

Mixing and Blending Pulps

To get a paper that has the desired color, strength, texture, writing surface, and other qualities, the right ingredients must be mixed together in the proper amounts. Softwood and hardwood pulps may be blended, and they may be mixed with recycled pulp. Papermaking chemicals and minerals are added: sizing, to make paper resist water and take ink; fillers, to fill the spaces between the fibers to improve the properties of the final paper; and dyes, to add color.

To be used in papermaking, baled pulp is repulped in water to make a slurry.



Mixing Things Up. In the paper mill, different pulps are combined, and papermaking chemicals and minerals are added.

Forming the Sheet

Modern papermaking machines, running at speeds above 60 miles per hour, can make continuous sheets of paper up to 33 feet wide.

At the *wet end* of the papermaking machine, the well-blended pulp (99 percent water at this stage) is spread onto a long, wide, endlessly moving screen called forming fabric. Right away, water begins to drain from the bottom of the forming fabric. The water is collected and recycled. On the top side of the wire, fibers from the pulp catch and begin to bond together in a thin mat. Vacuum is used to suck more water from the mat, but when the wet paper leaves the wire, it is still mostly water (75 percent).

To press out more water, the wet paper is squeezed between heavy presses. The paper, supported on endless fabric loops called felts, leaves the wet end of the papermaking machine. As it moves rapidly to the *dry end*, the paper passes between huge metal cylinders that are steam-heated. These hot cylinders heat and dry the wet sheet.

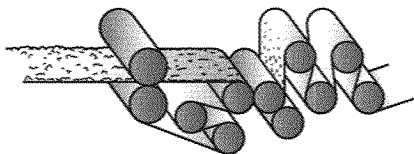

On the paper machine, a vacuum pulls water through the bottom of the forming fabric. The paper machine also has presses—rollers—that squeeze water out of the paper.

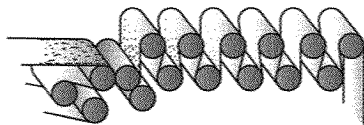

Temperature Rising: The Dryers. The steam-heated cylinders of the main dryer heat and dry the paper. Then the sheet may go through a size press, where a starch solution is applied to seal both sides of the paper before it passes through an afterdryer.

More heavy cylinders press, or iron, the drying paper smooth. This part of the machine, called a *calender stack*, evens the surface and makes the paper all the same thickness.

Coating the Paper

Either on the paper machine or afterward, paper can be coated. Most of the time paper is coated to improve its smoothness so it will print better. These coatings are usually composed of minerals like calcium carbonate or clay and combined with binders like starch or latex. The thick coating slurry is applied to one or usually both sides of the paper in a very thin layer with rollers or other devices. The wet coating layer is dried with steam-heated dryer cylinders, just like those that were used to dry the wet sheet before it was coated. The coating stays mostly on the surface of the paper, so a very thin layer—perhaps 10 to 20 percent of the total sheet weight applied to each side—is sufficient to greatly improve the smoothness and brightness of the paper.

Coatings can be made more glossy (for example, for calendars or magazine covers) by careful choice of the coating components and also by pressing or even buffing the coated sheet after it is dried. Functional coatings are applied for special purposes like thermal printing paper (for cash register receipts and portable printers), multipart forms, protective coatings such as anti-tarnish or moisture resistant coatings for wrapping small metal parts, and adhesive coatings for stick-on labels and tapes.

Wax is applied to paper to make waxed papers in a process similar to coating. Wax papers are not true coated papers, because the wax actually saturates the sheet completely rather than coating the surface only. Some types of surface treatments are applied with completely different processes. For example, milk cartons are extrusion coated (the plastic coating is applied at high temperatures, near its melting point), and foil-coated papers are usually made by laminating sheets of foil onto the paper with a binder. These special coatings are applied separate from the papermaking process.

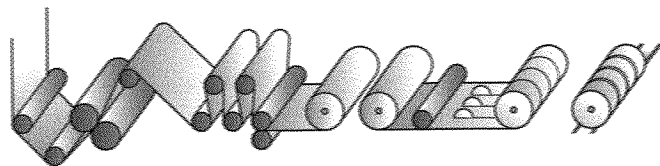
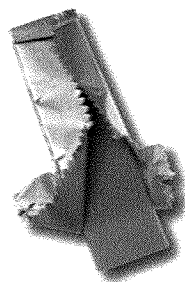

All Rolled Up. The paper passes through a calender stack that gives it a smooth and even surface. Then it's collected on a large reel in jumbo rolls that weigh 40 tons or more. On the winder, the rolls are slit to desired widths and wound on cores, ready to be shipped to customers or cut into smaller sheets.

Winding and Slitting the Paper

When the paper is dry, it's wound onto a big spool or reel. These jumbo rolls of paper can be slit into smaller rolls for sale or for further processing. From these rolls come printing, publishing, and writing papers, newsprint, tissue, wrappers and bags, cartons and boxes, plates and cups, envelopes, and many other products.

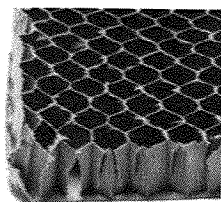

Corrugated board is made on machines called corrugators. Various types of converting machines are then used to make boxes out of the board.

Converting

The process of making paper products from the large rolls coming off the paper machine is known as *converting*. Paper is slit and cut to the right size and shape, and may be bent, folded, and glued to form the final product. Some paper is overlaid with a thin sheet of plastic, called laminating. Much paper is formed into folded cartons, such as cereal boxes, and into *corrugated* board, used for making shipping boxes.

Corrugated Board

Companies ship products such as light bulbs, glassware, and your new DVD in corrugated boxes to secure and protect them from damage. A whopping 95 percent of all manufactured goods are shipped in corrugated boxes.

Corrugated packaging is made from two flat sheets of paper called *liners* glued to a middle layer that has ridges and grooves—the *fluting*. This construction is like a sandwich with a filling of connected arches, which can support a lot of weight. The three-layer structure makes corrugated board rigid, strong, and hard to crush. The air circulating in the flutes (the grooves) also acts as an insulator, protecting against changes in temperature.

What many people call cardboard is known to papermakers as *paperboard*. This stiff type of paper is used in food packaging (such as cereal boxes) and for other kinds of containers such as shoe boxes and video game boxes. *Corrugated* paper is folded into ridges and grooves, giving it a strong structure when glued between two sheets of liner.

Get samples of paperboard and corrugated and compare them. You can find many examples of paperboard in the kitchen, in food packages. For corrugated, cut a piece from a shipping carton and peel apart the layers to see the fluting inside.

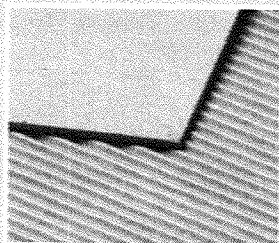

All of these things make corrugated board a good material for packaging and shipping. Manufacturers use it to pack, stack, cushion, and transport their products to stores and individual customers. Afterward, used boxes and cartons made of corrugated board can be recycled into new paper and board.

Visiting a Mill or Plant

For your work on this merit badge, you may choose to visit a pulp or paper mill, or a container plant or box plant. The United States has more than 350 paper and pulp mills, found—as you might expect—in forested areas but also in urban areas. Some are in the Pacific Northwest. Many operate in the South, in the lake states, and eastward through the Middle Atlantic States and New England.

Work with your merit badge counselor to arrange a visit to a pulp or paper mill in your area. To find a box plant to visit, check your local telephone directory under “Boxes—Corrugated” and “Boxes—Paper.” You can also search the internet for paper mills and box manufacturers.

Companies that manufacture corrugated boxes and paper cartons are located nationwide, in cities large and small. There are about 450 box plants in the United States.

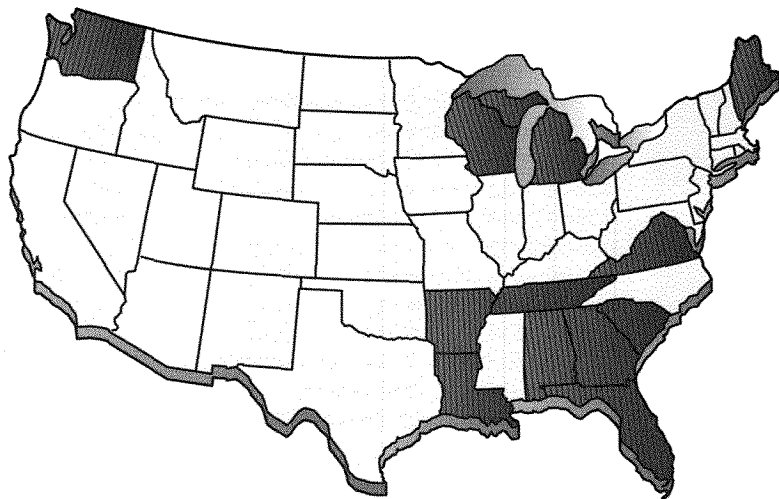

As of 2010, the 12 states ranking highest in paper production were Alabama, Georgia, Louisiana, Wisconsin, South Carolina, Washington, Virginia, Maine, Michigan, Arkansas, Florida, and Tennessee. As of 2010, 63.5 percent of paper and boxes were recovered and recycled. The 12 states that rank the highest in recycling were Georgia, Wisconsin, New York, Louisiana, Alabama, Michigan, Virginia, Oklahoma, Washington, Maine, Oregon, and California.



How We Use Paper Today

Here's an astonishing number to digest. Each person in the United States uses about 700 pounds of paper each year. Paper is everywhere in our lives. Every year in the United States, more than 2 billion individual books, 24 billion newspapers, and 350 million magazines are published on paper. Movie tickets, popcorn tubs, cereal boxes, cash register receipts, crayon wrappers, paper board games, your television set, and even the LCD screens in your cell phone contain paper.

How could you possibly get through your school day without using paper? How about money, checks, birth certificates, marriage licenses, permits, and all of the documents we need to go about our daily lives?

The home you live in was built with wood and paper products. Those laminated kitchen countertops, the insulation that keeps your house cool in summer and warm in winter, gypsum wallboard, wallpaper, flooring, and shingles—all are at least partly paper. Sandpaper, electrical cable wrapping, and masking tape all have paper backing.

In our world today are more than 6,000 products made from paper. Listed are some everyday examples you can find all around you. What other paper products can you think of or find in your home? What new products are being developed? (You may discover several fascinating examples if you do requirement 7e, about research and development in the papermaking industry.)

At School and Work

Books
 Business cards
 Calendars
 Copier and printer paper
 Envelopes
 Maps
 Masking tape
 Notebook paper
 Paper money and checks
 Postage stamps
 Poster board
 Report cards

At Home

Cereal boxes
 Countertops
 Egg and milk cartons
 Facial and toilet tissue
 Grocery bags
 Lamp shades
 Magazines and newspapers
 Microwave-food containers
 Paper towels, plates
 and cups
 Pizza boxes
 Rayon clothing
 Tea bags
 Waxed paper
 Wallpaper
 Window shades
 Wrapping paper

In Medicine and Technology

Bandages
 Filters and gaskets
 Hospital and surgical gowns
 LCD screens
 Medical charts
 Surgical dressings

Sutures
 Pollen and dust masks

Just for Fun

Board games
 Bumper stickers
 Coloring books
 Confetti
 Gum and candy wrappers
 Jigsaw puzzles
 Kites
 Paper airplanes
 Party hats
 Photographs
 Stickers
 Streamers
 Tickets
 Trading cards

Products From Byproducts*

Caulk and putty
 Cellophane
 Cellulose sponges
 Chewing gum
 Combs and
 brush handles
 Eyeglass frames
 Furniture polish
 Ink
 Paint and varnish
 Perfume
 Photographic film
 Pine oil
 Sausage casings
 Shoe polish
 Suntan lotion
 Turpentine

*These items are made from byproducts of the papermaking process.

People pretty
 much take paper
 for granted, but
 we would be
 hard-pressed to
 live without it.

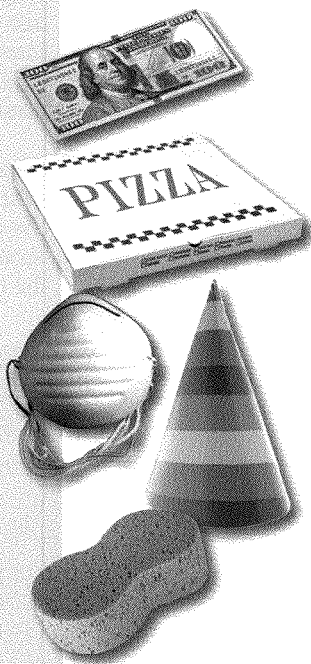

New Paper From Old: Recycling

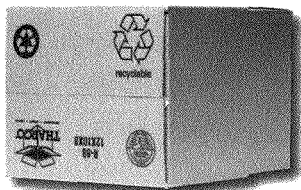

More than a third of all the papermaking fiber used at American mills comes from recycled paper. Papermaking fibers can be reused multiple times before they become too short to bond together. Newspapers are often recycled into tissue and paperboard. Magazines, in their second life, may become newsprint. When magazines are printed on glossy paper, the clay that was added to the paper to make it glossy actually helps separate the ink from the paper during recycling.

What happens when you recycle a piece of paper? The process begins when you gather up wastepaper—old newspapers, magazines, office and computer paper, and corrugated boxes—and put it in a recycling bin. It's best to keep all paper products intended for recycling out of sunlight and wet weather, because exposure to the elements makes it harder to remove the ink from the paper.

The paper is collected, sorted, wrapped in tight bales, and transported. Once it reaches a recycling facility, repulping is next. In a pulper—a big vat containing water and chemicals—the wastepaper is chopped into small pieces. Heat helps to further break down the old paper into fibers, thus turning the mixture into pulp.

Recyclers Wanted

In the United States, more paper is recycled than is buried in landfills. That is good for our environment, but we need to do better. According to the Weyerhaeuser Company 2003 Citizenship and Environment Report:

Current trends in recycling are not encouraging. . . fewer consumers are making the effort to recycle. Some research indicates that consumers in their 20s and 30s are less committed to recycling than consumers in their 40s and 50s, who came of age at a time of vigorous public education efforts on the merits of recycling.

You and your fellow Scouts are coming of age now. Will you be part of the problem, or part of the solution? Remember the three R's: **Reduce, Reuse, Recycle.**

The pulp is screened to remove small contaminants. It's further cleaned by spinning it around in cone-shaped cylinders. Heavy bits like staples and paper clips are thrown to the side of the cone and fall out the bottom. Lighter contaminants collect in the center of the cone and are removed.

To get the ink out, a process known as deinking, the pulp is washed to rinse away loose ink particles. Soaplike chemicals are added to make the remaining ink float to the surface, where it is skimmed away, leaving clean pulp behind. The ink, along with clay, glue, and other materials and impurities removed during deinking, can be burned for energy to run the recycling facility.

The pulp, minus all the ink, goes for refining and, if necessary, for color stripping and bleaching. (Pulp for making brown recycled paper, such as that used for industrial paper towels, doesn't need to be bleached.) From this point, the pulp is used just as it would be if it had been made from fresh wood chips rather than recycled paper. Papermakers may use the recycled fiber alone, or combine it with varying amounts of new wood fibers to produce different kinds of paper. Recycled fibers can be made into many new products including boxes, newsprint, napkins, towels, tissue, writing paper, envelopes, egg cartons, and paper bags.

What's great about recycling is that, in the end, a new paper product is created from material that might have ended up instead in a landfill. Recycling is an excellent way people and papermakers can work together to have a cleaner and more sustainable environment.

The industry is trying to cut down on its need for new fiber taken from trees. New technologies are being developed to make paper with less fiber, and to make even more products with wastepaper and recycled fibers. Though most recovered paper is recycled back into paper and paperboard products, it can be used for such purposes as insulation and roofing—even animal bedding, cat litter, and fuel.

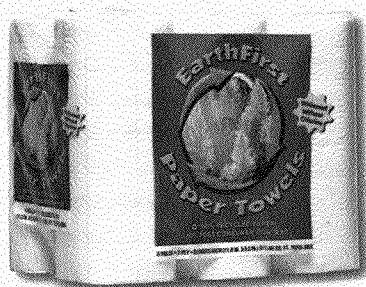
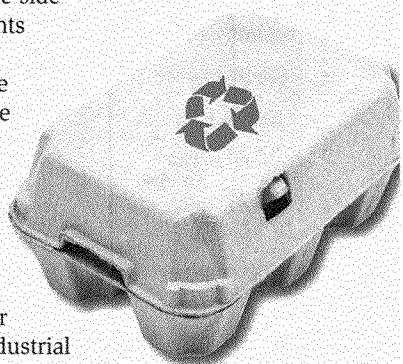

Every day, U.S. papermakers recycle enough paper to fill a train of boxcars 15 miles long.

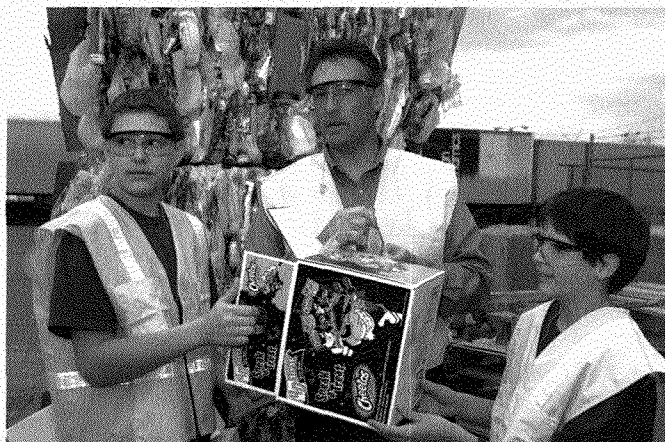

The United States is the world's largest paper recycler, with more than 200 mills now using recycled paper. Even so, the wastepaper that we Americans throw away makes up almost a third of all the trash that goes into landfills. We could save a lot of landfill space if we would start thinking of wastepaper as a valuable resource rather than as trash. We could also save energy. Recycling uses half the energy needed to manufacture paper from new wood. Think about that the next time you throw away a piece of paper.

Reusing Water and Leftovers

Recycling is important in many ways in the pulp and paper industries. Fiber from recycled paper isn't the only thing that gets recovered and reused.

- Millions of gallons of water are used in papermaking. The water is recycled, up to 25 times, to cut down on the need for fresh water.
- The chemicals necessary in pulping and papermaking are recovered and reused to keep them out of rivers and streams. Useful products such as turpentine or lignin are drawn off and saved. Recovery and recycling keeps many potentially hazardous chemicals from ever reaching the environment outside the mill.



- Making paper takes an enormous amount of energy, but pulp and paper mills can generate energy by burning waste wood, bark stripped from logs, and used chemicals for fuel. Heat from the paper-drying process is captured, and the energy is used in other parts of the mill. From its leftovers, the paper industry generates more than half of the energy it uses—more than any other major industry in the world. Some mills are almost completely self-sufficient in energy.

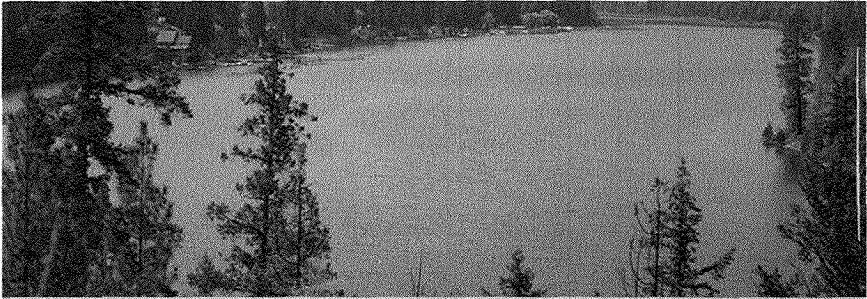

Looking to Nature

Some of the strongest chemicals used in papermaking are the bleaching chemicals that whiten pulp. Researchers are looking for more environmentally friendly bleaching agents. One promising approach uses enzymes—natural chemicals made by living things—that work in a clean, biological way. Enzymes are also used as an energy-efficient method of removing ink from recycled newspapers and magazines.

Other researchers are interested in a fungus that chews through the lignin in wood to predigest wood chips, making them softer and easier to tear apart into fibers. Mechanical pulping using “biopulped” wood chips takes less energy. And because the pulp has less lignin, paper made from this kind of pulp is stronger and less prone to discolor.

Researchers are also looking for advanced uses of nanocrystalline cellulose. This material, which is extracted during the pulping process, is stronger than steel. Scientists are trying to discover how this super-strong byproduct can be used to reinforce carbon fiber structures, making that synthetic material stronger and more stable. Carbon fiber is used in many products, from fishing poles and golf clubs to boats and footballs.

These are just several examples of research in the paper industry aimed at reducing pollution, protecting the environment, and improving the products. What other new ideas can you find out about?

Making Paper by Hand

Now that you know how paper is made, make some at home and practice this centuries-old art. After your own papermaking session, you will develop a deeper appreciation for paper in its many forms: no-frills copier paper, shipping boxes, Scouting books, and bags for everything from grass clippings to groceries and gifts—even your homework papers.

Be aware that papermaking is messy. Be sure you get an adult's OK before starting. Wear old clothes and set up your workstation in a clean, safe area that will not disrupt others. If the weather is nice, you can work outside on a picnic table or patio area. If you are working inside, be sure to protect the floor by spreading newspapers under your work area.

Preparation is the key element in successfully making paper. Before you begin working, gather all the supplies and materials in your work area. Read these instructions from beginning to end and review until you are familiar with the complete process and know what supplies you will need for each step.

Papermaking

Making the Mold and Deckle

Step 1 (if using frames)—Place a large piece of screen on a flat surface and center one of the blank wooden frames over it, front side down. Fold one long side of the screen over the edge of the frame and secure it to the back of the frame with staples or thumbtacks. Do the same with the other long side of the screen, pulling gently for a snug fit, and staple or tack it in place. Do the same with the short sides of the screen and frame. This is your papermaking mold. The other blank frame will serve as the deckle when the frames are held together face-to-face with the screen in the middle.

Basic Supplies Needed

- Fine mesh fabric, flexible plastic screening, or stiff nylon netting
- Two inexpensive 8-by-10 wooden frames or a large wooden embroidery hoop
- Staples or tacks
- Assorted scrap papers:
 - Unprinted computer paper or copy paper
 - Household paper (facial tissues, toilet paper, napkins, or paper towels)
 - Paper bags
 - Construction paper
 - Index cards, old greeting cards, or cardstock scraps
- Large measuring cup
- Large mixing bowl
- Bowl scraper or rubber scraper
- Large wire whisk or hand-held eggbeater
- Newspapers (to cover floors)
- Plastic basin or tub (bigger than your papermaking mold)
- Cookie sheets or large, flat trays
- Towels, absorbent cloths, newspapers, or paper towels (for couching)
- Sponges
- Spatula
- Rolling pin
- Paper-size pieces of felt, flannel, or any other thin cloth (for drying)

Step 1 (if using a hoop)—Center the screen over the inside hoop, slide the outer hoop about halfway down from the top, and tighten the clamp to hold the screen in place. To form the deckle, position the outer hoop only halfway down. Gently tug on the screen outside the hoop to eliminate any loose areas inside the hoop.

Step 2—Make sure the screen is stretched tight across the frame or hoop. If necessary, loosen the tacks or hoop clamp and tug on the screen to tighten any loose areas.

Step 3—When the screen is smooth and tight, trim away any excess.

A deckle is a frame placed on top of the mold to define the paper's edge.

In the early days of printing, all paper had a deckle edge. The automation of papermaking, when paper was produced in long rolls, eliminated this uneven edge. Deckled edges later became a status symbol.

If you can't start using the mold and deckle right away, put it in a box to protect the screen from nicks, bumps, or stretching. Handle the mold and deckle carefully—only by the sides—to help prevent the screen from stretching.

To create interesting effects, use a combination of paper colors, types, textures, and weights. Be sure to have a good mix of weights so the paper is not too bulky or too flimsy.



Making Paper

Step 1—Tear (*do not cut!*) the scrap paper into small pieces about the size of a postage stamp, or about an inch square. Tear up at least 6 cups of scraps. (You will need 4 cups for papermaking, plus extra in case the pulp slurry is too thin.)

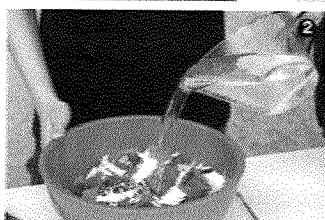

Step 2—Place 4 cups of paper scraps in the mixing bowl and add enough warm water to cover the pieces, about 2 cups. As the scraps start absorbing water, they will break down into a soggy mush called “pulp.” Use the bowl scraper to stir the mix so all the scraps absorb water.

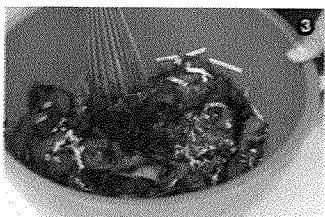

Step 3—Use the whisk or eggbeater to mix the pulp until all fibers are separated and evenly distributed. You can use your hands to break up any clumps. Pulp that includes cardstock scraps may need additional whisking or beating.

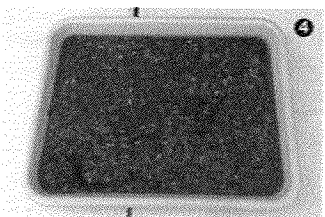

Step 4—Carefully pour the pulp into the basin and add water until the basin is about half full. This slurry should have the consistency of thin, watery oatmeal. The thicker the slurry is, the thicker the paper will be. Add more warm water if the slurry is too thick. If it is too thin, make another batch of pulp and stir it in, a little at a time, until it is the right consistency.

Step 5—Set up the couching area now so it is ready when you need it in step 9. Fold the absorbent cloths into a pad about an inch thick and a little bigger than the papermaking mold. Place the pad on the cookie sheet and put the cookie sheet on a flat, stable surface where there is room to work.

Couching (pronounced “cooch-ing”) is the process of transferring the paper from the mold to the surface where it will dry.

Step 6—Stir the slurry again. If you are using frames, hold the mold screen-side up and place the other frame (the deckle) on top. This will ensure the paper’s edges are straight.

Step 7—Hold the mold/deckle firmly and lower them into the slurry at a 45-degree angle, changing to a horizontal hold when they are below the slurry line. Still keeping a firm grip on the mold/deckle, swirl them around in the slurry to set the fibers in motion. Keep the mold/deckle level to ensure the paper will have the same thickness above all areas of the screen. With the slurry still in motion, gently lift the mold/deckle straight up out of the mix and check the pulp layer.

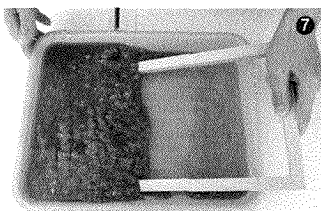

Step 8—Gently shake the mold/deckle from side to side, then back and forth over the basin to help drain off water. If the screen is not completely covered, return the mold/deckle to the pulp slurry and swirl it around again. If the pulp layer is uneven, jiggle the mold a little to help even out the pulp. If there are holes in the pulp layer, thicken the slurry with more pulp, then swirl the mold/deckle in the slurry again. With practice you will learn what works best for the type and weight of paper you want to make. When you are satisfied with the pulp layer, keep holding the mold/deckle over the basin until the water stops dripping. If you are using the frame method, remove the deckle.



Step 9—It's now time for couching. Hold the mold over the couching pad. With a smooth, quick motion, flip it over and gently place it pulp layer down on the couching pad. Slowly roll the mold from one edge to the other to help loosen the sheet from the screen. You may need to pat a sponge against the back side of the screen, squeezing out water and pressing the paper flat on the couching pad until you see the paper separating from the screen. Use the spatula to gently separate the rest of the sheet and screen.

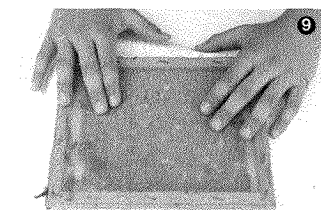

Step 10—Place a towel or a layer of paper towels on top of the sheet of paper. Use the rolling pin to firmly but gently press the towels into the sheet to remove more water. Keep rolling and replacing towels until no more water can be squeezed out of the sheet. Move the paper sheet and the top layer of the couching pad toweling to a drying area.



For a new papermaker, couching can be the trickiest part of the whole process. You will get better with practice.

Step 11—Repeat steps 7 through 10 to make as many sheets of paper as you wish. Before starting a new sheet, be sure to stir the pulp slurry. You can stack new sheets in the drying area to conserve space, but keep the stacks short to help the papers dry faster. Place a piece of drying cloth between each sheet, and top the stack with a drying cover. To speed up the process, place the stacks outside on a warm day or near a sunny window.

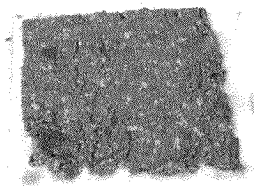

⑫ **Step 12**—Make sure all the sheets of paper are dry. Gently separate the layers of each stack, leaving each sheet on its drying cloth backer. Make sure each one is completely dry before peeling off the fabric backer.

Step 13—Paper may curl as it dries. To flatten, put the finished paper under a heavy book. Leave it overnight, and it will be flat the next day.

Note: If you have pulp left over, pour it through a strainer or the mold, then hand-squeeze the recovered pulp to thicken it further. The recovered pulp can be stored in jars for a few days in the refrigerator for later use, or it can be thrown in the compost bin or trash can. Do *not* pour pulp down the drain.

Customizing Papers

Once you have mastered basic papermaking techniques, branch out and customize your next paper batch. Special paper projects can include decorative additions, 3-D shaping, and watermarks.

Creative Effects

There is no limit to the number of creative paper effects you can make. Adding unusual colors to your handmade paper can be as easy as dripping a little food coloring or water-based ink into the pulp. Mix in small bits of confetti, tin foil, or glitter for extra pizzazz. Crumble dried flower petals, leaves, grasses, ferns, or dried herbs to create natural effects. For sturdier paper, you can increase the fiber content with burlap fibers or shredded cotton balls (real cotton works better than synthetic cotton). Add snippets of yarn or thread to the pulp to give your paper a touch of color.

3-D Paper

Let your imagination be your guide to creating all sorts of artful objects with your handmade paper. Create a paper bowl by couching a sheet of damp paper over an overturned bowl. Fold and smooth the sides, then let

the paper dry in place. A similar technique can be used to make a paper tray. Make napkin rings by wrapping slender strips of paper around a smooth tube and couching it from the outside.

Watermarks

A *watermark* is an image that is embossed in paper and can be seen only by holding the paper up to a light. Watermarks are often used as security measures. For example, banknotes with watermarks help prevent forgeries, and legal papers with a watermark make it easy to tell an original document from a copy. Personal stationery can be customized with a watermark design that has special meaning to the user.

Step 1—Think of what you might want for a watermark, such as your initials, a symbol, or a design of your own.

Step 2—Sketch your ideas and consider how each drawing will work as a watermark. Eliminate designs that are too elaborate, too stark, or too big for the size of paper you plan to make. The best watermark will come from a simple design with a few lines that form a recognizable image.

Step 3—Draw your final design on a piece of paper. As you draw, make sure the lines can be seen through the screen of your mold.

Step 4—Protect your design by making a copy of your final drawing, and keep the original in a plastic sheet protector. If your watermark paper mold is ever lost or damaged, you can make a new mold with the original drawing.

Step 5—Place the mold over your backup design copy, positioning it so that the watermark design shows through the screen where you want it to be on the finished paper. Use correction fluid, puff paint, or glue to carefully trace the design on the screening. Apply the fluid in small dabs, a little at a time, so that the lines of the design do not run together. Make sure the lines are not too wide or thick; otherwise, holes will form in the paper.

Step 6—Set aside the mold and let the design dry completely. Your watermark paper mold is now ready for making paper.



The watermark becomes a permanent part of the screening in your mold, so be aware that this will be a limited-use mold.

In addition to the papermaking supplies listed earlier, you will need correction fluid, puff paint, or waterproof wood glue to create your watermark.

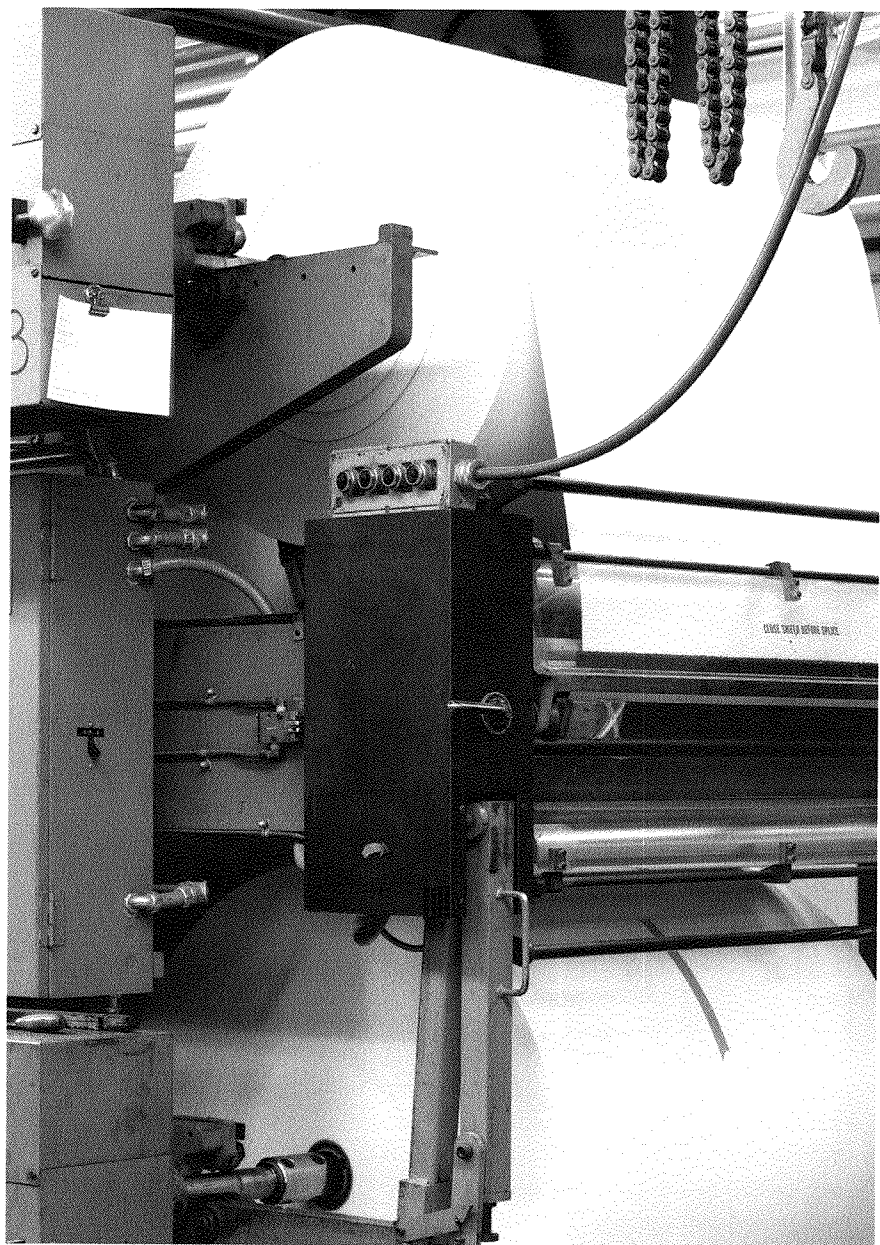

Careers in Pulp and Paper

The pulp and paper industry offers hundreds of different career possibilities. The work may include making paper, helping to protect the environment, running laboratory tests, process design, computer systems, working in a forest, or working in a corporate office. If you have enjoyed earning the Pulp and Paper merit badge, you may find the perfect career in this field. The industry needs trained people in many areas, including forestry, engineering, manufacturing, research and development, sales and marketing, and administration.

If you like to work outdoors and enjoy being in the woods, forestry might be the career for you.

Forestry and Timber Operations

Professional foresters manage the timberlands that provide wood fiber to the pulp and papermaking industry. Foresters plan and direct tree planting and timber harvesting. They help prevent damage from insects, disease, and fire. They know how to help trees grow, how to get more wood from an acre of land, and how to keep a never-ending supply of trees growing to meet the demand for wood fiber. It's also the responsibility of foresters to protect and manage wildlife, water, soil, and other forest resources. Foresters also plan for recreational uses of timberlands, including hiking, fishing, and camping.

Most foresters have at least a bachelor's degree in forestry. Many have advanced degrees. In college, forestry students take classes in biology, physical and social sciences, ecology, silviculture (the science of growing and harvesting trees and caring for forests), forest economics, forest protection, and resources management.



To prepare for an engineering or technical career, in high school you should study biology, chemistry, physics, mathematics, social studies, computers, and English.

Engineering

Engineers work to make pulp and paper mills more productive, safe, clean, and efficient. They supervise the mills' operations, design and oversee the construction of new mills, and make improvements to older manufacturing plants to reduce waste, prevent delays, and keep costs down. Civil, mechanical, chemical, industrial, and electrical engineering skills are all useful in this career.

Environmental engineering is another needed specialty. These professionals design and supervise systems to control pollution, protect the environment, protect the health and safety of people, and make sure that pulp and paper mills are good neighbors in their local communities. Education in paper science, chemical and civil engineering, biology, and chemistry can prepare you for a career as an environmental engineer. There are also academic programs in paper science and engineering.

Another position important to the industry is the systems engineer. This person is an expert in the control systems and computers that run high-speed paper machines.

Manufacturing

Modern pulp and paper mills need skilled people to plan mill operations, keep those operations running smoothly, and maintain the machinery so that pulp and paper production continues—oftentimes around the clock—with no breakdowns or interruptions. In addition to engineers, chemists, and other scientists, the workers needed in mill operations include electricians, pipe and steam fitters, and machine operators. Technical training is generally required for these positions.

Some examples of machine operators are

- *Wood yard operators*, who run the equipment that transforms logs into small chips to be made into pulp
- *Digester operators*, who are in charge of the big, kettlelike digesters that break down the wood chips through chemical action, heat, and pressure
- *Paper machine operators*, who adjust the flow of pulp onto the paper machine and, with the help of computer-controlled monitors, run and track the machine's functions
- *Backtenders*, who work at the dry end of a paper machine, operating the equipment that dries and smoothes the paper and winds it on rolls

Research and Product Development

Research and development professionals come up with the paper industry's new and improved ideas. They develop new paper products, find solutions to air and stream pollution, and devise more efficient production methods. In this field, formal training and advanced degrees are often required in physics, chemistry, chemical engineering, biochemistry, biology, mathematics, paper science, engineering, or ecology.



Quality control experts check to make sure a mill's finished paper products are of high quality. They test sample sheets for strength, brightness, and weight, and direct laboratory tests to look for flaws in the paper. People working in quality control often have backgrounds in industrial engineering or chemistry.

Sales and Marketing

After the products are created, they must be marketed to a large variety of users. Salespeople identify potential clients and explain or demonstrate their company's products. If they make a sale, they follow up to be sure the customer is satisfied. People who have a flair for sales and marketing combined with an engineering or technical background do well in these positions. There are also sales and marketing positions available at companies that supply equipment, chemicals, and services to pulp and paper manufacturers.

Administration

In every company, there are management and administrative positions, and positions for accountants, computer programmers, and legal professionals. Many college graduates who go into the paper business become managers early in their careers.

Are you interested in traveling overseas? The U.S. paper industry has a global market, and its professionals often go to other countries to oversee or expand a company's operations. It's not unusual for people in the paper business, or for those in engineering consulting, to spend a year or more on assignments abroad.

Career opportunities also exist in related industries, including agriculture, product packaging and containers, chemical products, industrial products, scientific instruments, machinery, printing, and consulting.

Papermaking Resources

Scouting Literature

Chemistry, Energy, Engineering, Environmental Science, Fish and Wildlife Management, Forestry, Graphic Arts, Soil and Water Conservation, Sustainability, and Textile merit badge pamphlets

With your parent's permission, visit the Boy Scouts of America's official retail website, www.scoutshop.org, for a complete listing of all merit badge pamphlets and other helpful Scouting materials and supplies.

Books

Asunción, Josep. *The Complete Book of Papermaking*. Sterling, 2003.

Couzins-Scott, Elizabeth. *Papermaking: 25 Creative Handmade Projects Shown Step By Step*. Lorenz Books, 2014.

Dawson, Sophie. *The Art and Craft of Papermaking: Step-by-Step Instructions for Creating Distinctive Handmade Paper*. Sterling, 1999.

Draper, Allison Stark. *Choosing a Career in the Pulp and Paper Industry*. Rosen Publishing Group, 2001.

Grummer, Arnold. *Arnold Grummer's Complete Guide to Easy Papermaking*. Krause Publications, 1999.

Hiebert, Helen. *The Papermaker's Companion: The Ultimate Guide to Making and Using Handmade Paper*. Storey Books, 2000.

Rainey, Rhonda. *Papermaking for the First Time*. Sterling, 2004.

Reimer, Mary. *300 Papermaking Recipes*. Martingale and Company, 2006.

Saddington, Marianne. *Making Your Own Paper: An Introduction to Creative Paper-Making*. Storey Books, 1992.

Saltman, David. *Paper Basics: Forestry, Manufacture, Selection, Purchasing, Mathematics and Metrics, Recycling*. Krieger Publishing, 1991.

Toale, Bernard. *The Art of Papermaking*. Davis Publications, 1983.

Woods, Samuel G. *Recycled Paper: From Start to Finish*. Blackbirch Press, 2000.

Organizations and Websites

American Forest and Paper Association

1101 K St., NW, Suite 700

Washington, DC 20005

Telephone: 202-463-2700

Website: www.afandpa.org

Robert C. Williams Museum of Papermaking

Renewable Bioproducts Institute
Mail code 0620, Georgia Tech
Atlanta, GA 30332-0620
Website: www.paper.gatech.edu

Society of American Foresters

10100 Laureate Way
Bethesda, MD 20814-2198
Toll-free telephone: 866-897-8720
Website: www.eforester.org

Society of Wood Science and Technology

P.O. Box 6155
Monona, WI 53716-6155
Telephone: 608-577-1342
Website: www.swst.org

Wisconsin Paper Council

10 E. Doty St., Suite 445
Madison, WI 53703
Telephone: 608-467-6025
Website: www.wipapercouncil.org

Acknowledgments

For assistance in updating the *Pulp and Paper* merit badge pamphlet, the Boy Scouts of America thanks Terry Bliss, Ph.D., Ashland Water Technologies Group; Michael J. Kocurek; and John Sunderland, Pulp and Paper Safety Association.

The Boy Scouts of America is grateful to the men and women serving on the National Merit Badge Subcommittee for the improvements made in updating this pamphlet.

Thanks also to those who contributed to previous editions of this pamphlet, lending a level of expertise that continues to guide the BSA's approach to this fascinating subject:

- Dick Madsen of Weyerhaeuser Company, one of the world's largest forest products companies and a winner of many awards for social responsibility and environmental protection
- T.J. Stenuf, Ph.D., and Richard A. Horn of Pulp, Paper, and Composites Research, USDA Forest Service, Forest Products Laboratory, Madison, Wisconsin, who helped revise previous editions
- TAPPI, the Technical Association of the Pulp and Paper Industry, for its cooperation in the production of the pamphlet

Photo and Illustration Credits

American Paper Institute, courtesy—
page 6

©Realworld Imagery Inc.—pages 13
and 14 (*trees*)

Shutterstock.com—cover (*paper
samples*, ©Robbi; *plant*, ©arka38;
logs, ©Richard Peterson); pages 2
(©Robbi), 8 (©Anest), 12 (©Ekaterina
Kondratova), 15 (*forest*, ©Bildagentur
Zoonar GmbH), 23 (*wood chips*,
©aabeele), 25 (©LI CHAOSHU), 27
(*gum wrapper*, ©rorem), 31 (*money*,
©Andrey Lobachev; *pizza box*,
©Balefire; *dust mask*, ©digitalfarmer;
party hat, ©spe; *sponge*, ©Namning),
33 (*egg carton*, ©design56), 34
(*trash can*, ©Africa Studio), 36
(©val lawless), 37 (©David M.
Schrader), 41 (©isak55), and
42 (©Kenneth Sponsler)

Stora Enso, courtesy—page 14 (*forester*)

U.S. Department of Agriculture, Natural
Resources Conservation Service/
Tim McCabe, courtesy—page 35

U.S. Department of Agriculture/
Bill Tarpinning, courtesy—
page 17

All other photos and illustrations not
mentioned above are the property of
or are protected by the Boy Scouts
of America.

John McDearmon—all illustrations
on pages 15–16, 20–21, 23–24,
and 26–27

Brian Payne—cover (*trading cards*);
page 34 (*recycling center*)

MERIT BADGE LIBRARY

Though intended as an aid to Boy Scouts, and qualified Venturers and Sea Scouts in meeting merit badge requirements, these pamphlets are of general interest and are made available by many schools and public libraries. The latest revision date of each pamphlet might not correspond with the copyright date shown below, because this list is corrected only once a year, in January. Any number of merit badge pamphlets may be revised throughout the year; others are simply reprinted until a revision becomes necessary.

If a Scout has already started working on a merit badge when a new edition for that pamphlet is introduced, *they may continue to use the same merit badge pamphlet to earn the badge and fulfill the requirements therein.* In other words, the Scout need not start over again with the new pamphlet and possibly revised requirements.

Merit Badge Pamphlet	Year	Merit Badge Pamphlet	Year	Merit Badge Pamphlet	Year
American Business	2013	Family Life	2016	Plant Science	2018
American Cultures	2013	Farm Mechanics	2017	Plumbing	2012
American Heritage	2013	Fingerprinting	2014	Pottery	2008
American Labor	2018	Fire Safety	2016	Programming	2013
Animal Science	2014	First Aid	2015	Public Health	2017
Animation	2015	Fish and Wildlife		Public Speaking	2013
Archaeology	2017	Management	2014	Pulp and Paper	2013
Archery	2015	Fishing	2013	Radio	2017
Architecture and Landscape Architecture	2014	Fly-Fishing	2014	Railroading	2015
Art	2013	Forestry	2015	Reading	2013
Astronomy	2016	Game Design	2013	Reptile and	
Athletics	2016	Gardening	2013	Amphibian Study	2018
Automotive Maintenance	2017	Genealogy	2013	Rifle Shooting	2012
Aviation	2014	Geocaching	2016	Robotics	2016
Backpacking	2016	Geology	2016	Rowing	2014
Basketry	2017	Golf	2012	Safety	2016
Bird Study	2017	Graphic Arts	2013	Salesmanship	2013
Bugling (see Music)		Hiking	2016	Scholarship	2014
Camping	2018	Home Repairs	2012	Scouting Heritage	2017
Canoeing	2014	Horsmanship	2013	Scuba Diving	2009
Chemistry	2018	Indian Lore	2008	Sculpture	2014
Chess	2016	Insect Study	2018	Search and Rescue	2018
Citizenship in the Community	2015	Inventing	2016	Shotgun Shooting	2013
Citizenship in the Nation	2014	Journalism	2017	Signs, Signals, and Codes	2015
Citizenship in the World	2015	Kayaking	2016	Skating	2015
Climbing	2011	Landscape Architecture (see Architecture)		Small-Boat Sailing	2016
Coin Collecting	2017	Law	2011	Snow Sports	2017
Collections	2013	Leatherwork	2017	Soil and Water Conservation	2016
Communication	2013	Lifesaving	2017	Space Exploration	2016
Composite Materials	2012	Mammal Study	2014	Sports	2012
Cooking	2014	Medicine	2012	Stamp Collecting	2013
Crime Prevention	2012	Metalwork	2012	Surveying	2004
Cycling	2017	Mining in Society	2012	Sustainability	2013
Dentistry	2016	Model Design and Building	2010	Swimming	2014
Digital Technology	2016	Motorboating	2015	Textile	2014
Disabilities Awareness	2014	Moviemaking	2013	Theater	2014
Dog Care	2016	Music and Bugling	2013	Traffic Safety	2016
Drafting	2013	Nature	2014	Truck Transportation	2013
Electricity	2013	Nuclear Science	2017	Veterinary Medicine	2015
Electronics	2014	Oceanography	2012	Water Sports	2015
Emergency Preparedness	2015	Orienteering	2016	Weather	2013
Energy	2014	Painting	2016	Welding	2016
Engineering	2016	Personal Fitness	2016	Whitewater	2005
Entrepreneurship	2013	Personal Management	2015	Wilderness Survival	2012
Environmental Science	2015	Pets	2013	Wood Carving	2016
Exploration	2016	Photography	2016	Woodwork	2011
		Pioneering	2017		

BOY SCOUTS OF AMERICA • SUPPLY GROUP

NATIONAL DISTRIBUTION CENTER

2109 Westinghouse Boulevard

P.O. Box 7143

Charlotte, NC 28241-7143

To place an order,
call customer service
toll-free 800-323-0736
or go to
www.scoutshop.org

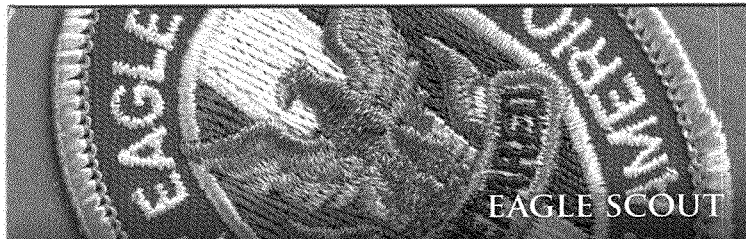

EAGLE SCOUT



THE SUMMIT



FLORIDA SEA BASE

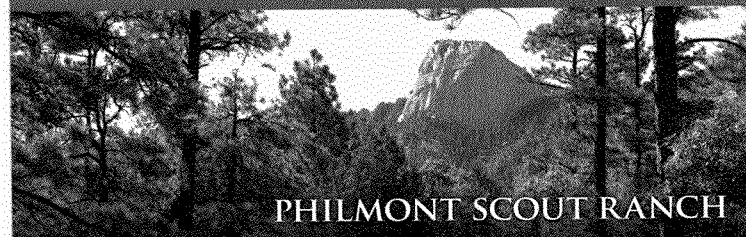

PHILMONT SCOUT RANCH

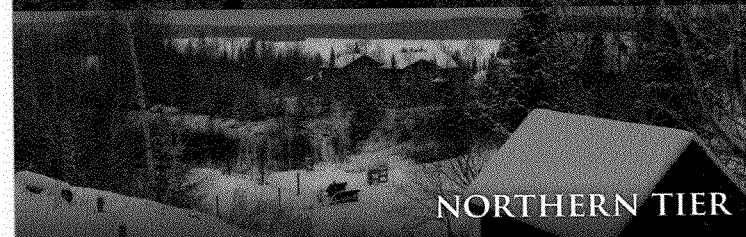

NORTHERN TIER

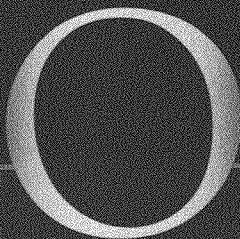

ON THE ROAD TO
HIGH ADVENTURE

THE SUPPLY GROUP IS
READY TO BE A PARTN
ON YOUR TRAIL TO
EAGLE THROUGH HIGH
ADVENTURE. THE
ADVENTURE IS YOURS
AND WE ARE READY
WITH THE GEAR YOU
WILL NEED. YOU CAN
DEPEND ON THE LATEST
IN LIGHTWEIGHT,
DURABLE, QUALITY
GEAR THAT WILL
MEET AND SURPASS
YOUR TOUGHEST
REQUIREMENTS.



WWW.SCOUTSHOP.ORG

SKU 649748



35937

2019 Print



Certified Source
www.sfi-program.org
91-00358